



User Manual

TM11E Elite 6-10kVA

Solutions behind the power

All rights reserved.

The information in this document is subject to change without notice.

Publish statement

Thank you for purchasing this series UPS.

This series UPS is an intelligent, single phase in single phase out, high frequency online UPS designed by our R&D team who is with years of designing experiences on UPS. With excellent electrical performance, perfect intelligent monitoring and network functions, smart appearance, complying with EMC and safety standards, The UPS meets the world' s advanced level.

Read this manual carefully before installation

This manual provides technical support to the operator of the equipment.

1:1

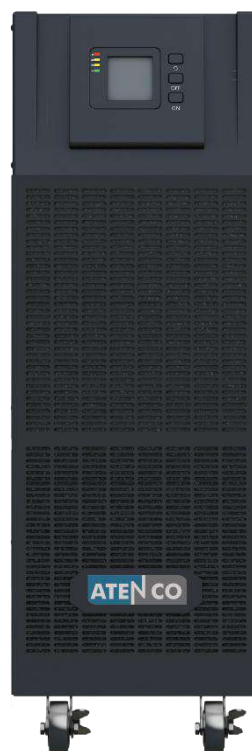

Contents

1. Safety	2
1.1 Safety notes	2
1.2 Symbols used in this guide	2
2. Main Features	3
2.1 Summarization	3
2.2 Functions and Features	3
3. Installation	4
3.1 Appearance of UPS	4
3.2 Cabinet Outlook	4
3.3 LCD control panel	6
3.4 Installation notes	6
3.5 External Protective Devices	7
3.6 Power Cables	8
3.7 Power cable connect	9
3.8 Battery connection	11
3.9 UPS parallel Installation	12
3.10 Computer access	13
4. Operation	15
4.1 Operation Modes	15
4.2 Turn on/off UPS	17
4.3 The LCD Display	20
4.4 Parameters setting	24
4.5 Display Messages/ Records	32
4.6 Options	34
Appendix 1 Specifications	36
Appendix 2 Problems and Solution	38
Appendix 3 USB communication port definition	39
Appendix 4 RS232 communication port definition	40
Appendix 5 RS485 communication port definition	41
Appendix 6 EPO instruction	42

1. Safety

Important safety instructions - Save these instructions

There exists dangerous voltage and high temperature inside the UPS. During the installation, operation and maintenance, please abide the local safety instructions and relative laws, otherwise it will result in personnel injury or equipment damage. Safety instructions in this manual act as a supplementary for the local safety instructions. Our company will not assume the liability that caused by disobeying safety instructions.

1.1 Safety notes

1. Even no connection with utility power, 208/220/230/240VAC voltage may still exist at UPS terminal!
2. For the sake of human being safety, please well earth the UPS before starting it.
3. Don' t open or damage battery, for the liquid spilled from the battery is strongly poisonous and do harmful to body!
4. Please avoid short circuit between anode and cathode of battery, otherwise, it will cause spark or fire!
5. Don' t disassemble the UPS cover, or there may be an electric shock!
6. Check if there exists high voltage before touching the battery
7. Working environment and storage way will affect the lifetime and reliability of the UPS. Avoid the UPS from working under following environment for long time
 - ◆ Area where the humidity and temperature is out of the specified range(temperature 0 to 40°C, relative humidity 5%-95%)
 - ◆ Direct sunlight or location nearby heat
 - ◆ Vibration Area with possibility to get the UPS crashed.
 - ◆ Area with erosive gas, flammable gas, excessive dust, etc
8. Keep ventilations in good conditions otherwise the components inside the UPS will be over-heated which may affect the life of the UPS.

1.2 Symbols used in this guide



WARNING!

Risk of electric shock



CAUTION!

Read this information to avoid equipment damage

2. Main Features

2.1 Summarization

This series UPS is a kind of single-in-single-out high frequency online UPS.

The UPS can solve most of the power supply problems, such as blackout, over-voltage, under-voltage, voltage sudden drop, oscillating of decreasing extent, high voltage pulse, voltage fluctuation, surge, inrush current, harmonic distortion (THD), noise interference, frequency fluctuation, etc..

This UPS can be applied to different applications from computer device, automatic equipment, communication system to industry equipment.

2.2 Functions and Features

- ◆Integrated solution for data center

UPS can be integrated with battery cabinet, offering excellent choice for data center.

- ◆Digital Control

This series UPS is controlled by Digital Signal Processor (DSP); enhance, it increases reliability, performance, self-protection, and self-diagnostics and so on.

- ◆Battery Configurable

From 16 blocks to 20 blocks, the battery voltage of this series UPS can be configured at 16 blocks, 18 blocks or 20 blocks, according to your convenience.

- ◆Charging Current is configurable

Via setting tool, the user may set the capacity of the batteries as well as reasonable charging current. Constant voltage mode, constant current mode or floating mode can be switched automatically and smoothly.

- ◆Intelligent Charging Method

The series UPS adopts advanced three-stage charging method—

1st stage: high current constant current charging

to guarantee to charge back to 90%;

2nd-stage: Constant Voltage

In order to vitalize battery and make sure batteries are fully charged

3rd stage: floating mode.

With this 3-stage charging method, it extends the life of the batteries and guarantees fast charging.

- ◆LCD Display

With LCD plus LED displays, the user may easily get UPS status and its operational parameters, such as input/output voltage, frequency & load%, battery % and ambient temperature, etc...

- ◆Intelligent Monitoring Function

Via optional SNMP Card, you may remotely control and monitor the UPS.

- ◆EPO Function

The series UPS may be completely shut off when the EPO is activated.

3. Installation

3.1 Appearance of UPS

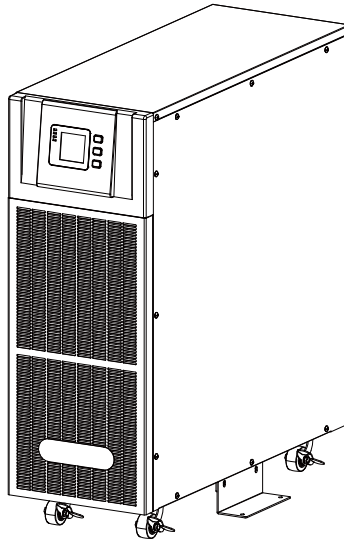

Standard type

3.2 Cabinet Outlook

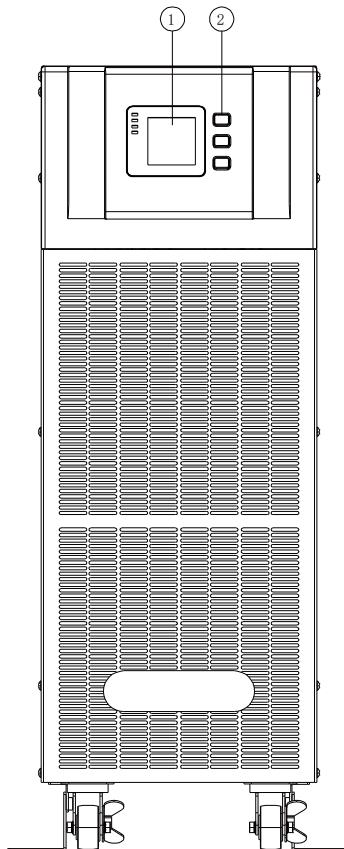

Front View of Standard type

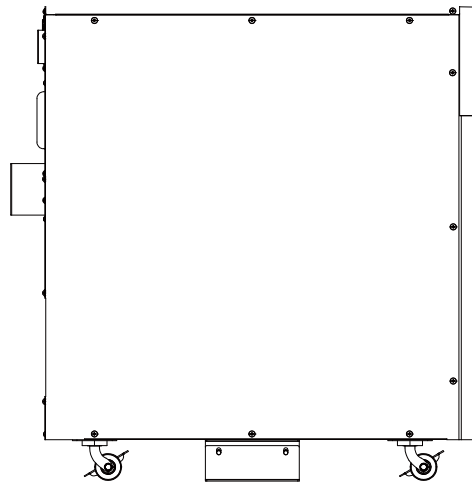

Side View of Standard type

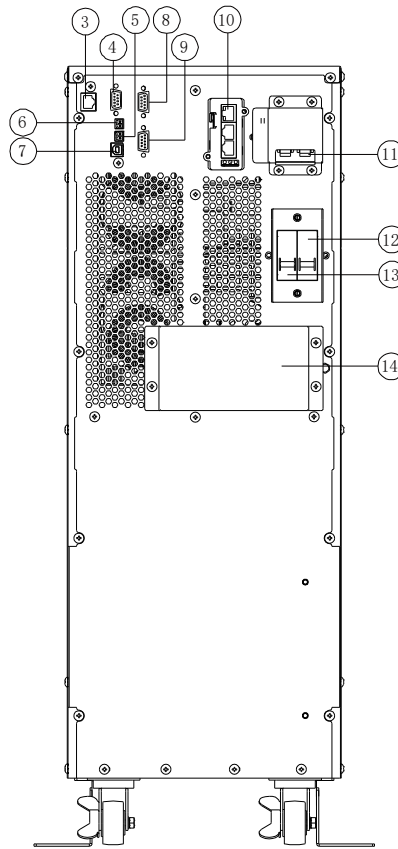

**Rear View of Standard type
 (with Maintenance)**

(1) LCD	(2) LCD Button
(3) RS485 port	(4) RS232 port
(5) EPO port	(6) MAINTAIN-AUXSWS port
(7) USB port	(8) Parallel port 2 (Optional)
(9) Parallel port 1 (Optional)	(10) Intelligent Slot
(11) Maintenance Bypass breaker (Optional)	(12) Input Breaker
(13) Output Breaker (Optional)	(14) Input & Output & Battery Terminal

3.3 LCD control panel

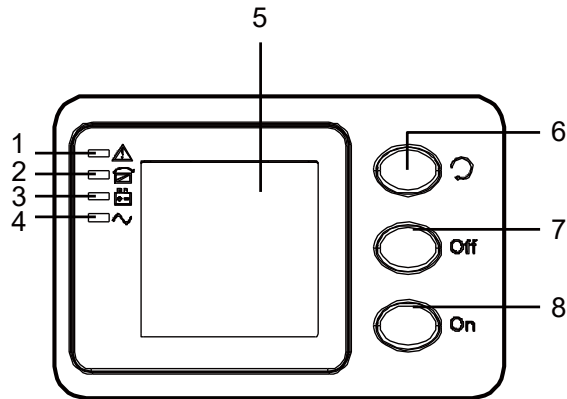

LCD control panel introduction

- (1) ALARM LED
- (2) BYPASS LED
- (3) BATTERY LED
- (4) INVERTER LED
- (5) LCD display
- (6) Scroll button: enter to next item
- (7) OFF button
- (8) ON button

3.4 Installation notes

Note: Consider for the convenience of operation and maintenance, the space in front and back of the cabinet should be left at least 100cm and 80cm respectively when installing the cabinet.

- ◆ Please place the UPS in a clean, stable environment, avoid the vibration, dust, humidity, flammable gas and liquid, corrosive. To avoid from high room temperature, a system of room extractor fans is recommended to be installed. Optional air filters are available if the UPS operates in a dusty environment.

- ◆ The environment temperature around UPS should keep in a range of 0°C ~ 40°C. If the environment temperature exceeds 40°C, the rated load capacity should be reduced by 10% per 4°C. The max temperature can't be higher than 50°C.

- ◆ If the UPS is dismantled under low temperature, it might be in a condensing condition. The UPS can't be installed unless the internal and external of the equipment is fully dry. Otherwise, there will be in danger of electric shock.

- ◆ Batteries should be mounted in an environment where the temperature is within the required specs. Temperature is a major factor in determining battery life and capacity. In a normal installation, the battery temperature is maintained between 15°C and 25°C. Keep batteries away from heat sources or main air ventilation area, etc.



WARNING!

Typical battery performance data are quoted for an operating temperature between 20°C and 25°C. Operating it above this range will reduce the battery life while operation below this range will reduce the battery capacity.

- ◆ Should the equipment not be installed immediately it must be stored in a room so as to protect it against excessive humidity and or heat sources.



CAUTION!

An unused battery must be recharged every 6 months Temporarily connecting the UPS to a suitable AC supply mains and activating it for the time required for recharging the batteries.

- ◆ The highest altitude that UPS may work normally with full load is 1000 meters. The load capacity should be reduced when this UPS is installed in place whose altitude is higher than 1000 meters, shown as the following table:

(Load coefficient equals max load in high altitude place divided by nominal power of the UPS)

Altitude (m)	1000	2000	2500	3000
Load coefficient	100%	90%	85%	80%

- ◆ The UPS cooling is depending on fan, so it should be kept in good air ventilation area. There are many ventilation holes on the front and rear, so they should not be blocked by any exotic obstacles.

3.5 External Protective Devices

For safety reasons, it is necessary to install, external circuit breaker at the input A.C. supply and the battery. This chapter provides guidelines for qualified installers that must have the knowledge of local wiring practices for the equipment to be installed.

◆ External Battery

The UPS and its associated batteries are protected against the effect of over-current through a DC compatible thermo-magnetic circuit-breaker (or a set of fuses) located close to the battery.

◆ UPS Output

Any external distribution board used for load distribution shall be fitted with protective devices that may avoid the risk of UPS overloaded.

◆ Over-current

Protection device shall be installed at the distribution panel of the incoming main supply. It may identify the power cables current capacity as well as the overload capacity of the system.

3.6 Power Cables

◆The cable design shall comply with the voltages and currents provided in this section, Kindly follow local wiring practices and take into consideration the environmental conditions (temperature and physical support media) .



WARNING!

Upon starting. Please ensure that you are aware of the location and operation of the external isolators which are connected to the UPS input/bypass supply of the mains distribution panel. Check to see if these supplies are electrically isolated. And post and necessary warning signs to prevent any inadvertent operation.



CAUTION!

In order to maintain compliance with the EMC directive for products sold in Europe, output cord attached to the UPS must not exceed 10 meters in length.

3.6.1 Recommended cross-sectional areas for power cables

UPS cabinet	Cable Dimension			
	AC Input (mm ²)	AC Output (mm ²)	DC Input (mm ²)	Grounding (mm ²)
6kVA	6	6	6	6
10kVA	10	10	10	10

- ◆ When selecting, connecting, and routing power cables, follow local safety regulations and rules.
- ◆ If external conditions such as cable layout or ambient temperatures change, perform verification in accordance with the local regulations.
- ◆ The nominal battery discharge current refers to the current of twenty 12 V batteries at 240V in standard configuration.
- ◆ The battery cable specifications are selected based on 16 batteries by default and compatible with application scenarios with 16–20 batteries.

3.6.2 Power cable connector requirements

Model	Connector	Connection Mode	Bolt Type	Bolt Hole Diameter	Torque
6kVA	Input connector	Crimped OT terminals	M4	4.5mm	3N•m
	Output connector	Crimped OT terminals	M4	4.5mm	3N•m
	Battery connector	Crimped OT terminals	M4	4.5mm	3N•m
	Grounding connector	Crimped OT terminals	M4	4.5mm	3N•m
10kVA	Input connector	Crimped OT terminals	M5	5mm	5N•m
	Output connector	Crimped OT terminals	M5	5mm	5N•m
	Battery connector	Crimped OT terminals	M5	5mm	5N•m
	Grounding connector	Crimped OT terminals	M5	5mm	5N•m

3.6.3 Recommended input front-end and output back-end circuit breakers

Model	Input circuit breaker	Maintenance circuit breaker	Output circuit breaker	Battery circuit breaker
6kVA	40A 1P	40A 1P	40A 1P	50A 2P
10kVA	63A 1P	63A 1P	63A 1P	63A 2P



CAUTION!

Protective earth cable: Connect each cabinet to the main ground system. For Grounding connection, follow the shortest route possible.



WARNING!

Failure to follow adequate earthing procedures may result in electromagnetic interference or in hazards involving electric shock and fire

3.7 Power cable connect

Once the equipment has been finally positioned and secured, connect the power cables as described in the following procedure.

Verify the UPS is totally isolated from its external power source and also all power isolators are open. Check to see if they are electrically isolated, and post any necessary warning signs to prevent their inadvertent operation.

Open the UPS rear panel; Remove the cover of terminals for wiring easily.

3.7.1 Input connection

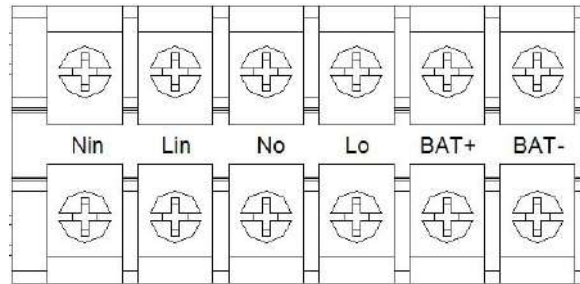

Lin: Primary input Phase L	Nin: Primary input Phase N
Lo: Output Phase L	No: Output Phase N
BAT+: Positive terminal of the batteries string	BAT-: Negative terminal of the batteries string
 : Grounding	

Choose appropriate power cable. (Refer to the table above) and pay attention to the diameter of the connection terminal of the cable that should be greater than or equal to that of the connection poles;

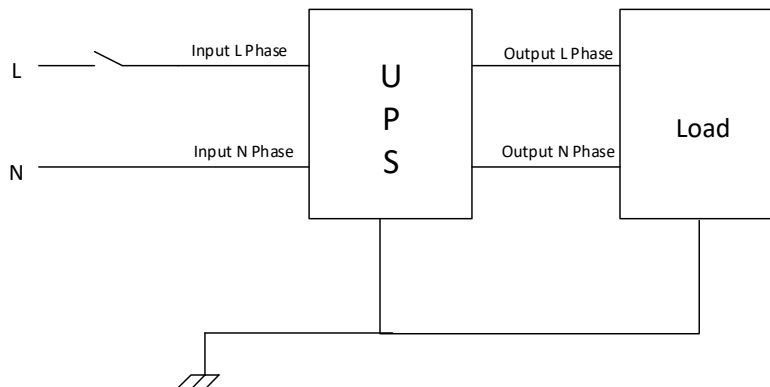

WARNING!

If the load equipment is not ready to accept power on the arrival of the commissioning engineer then ensure that the system output cables are safely isolated at their ends

Connect the safety earth and any necessary bonding earth cables to the copper earth screw located on the floor of the equipment below the power connections. All cabinets in the UPS must be grounded properly.



CAUTION!

The earthing and neutral bonding arrangement must be in accordance with local and national codes of practice.

3.8 Battery connection

3.8.1 External battery connection

The UPS adopts positive and negative battery framework, total 20(optional 16/18) in series. The user can choose the capacity and the numbers of the batteries according to their desire.

External battery connections for long-run units:

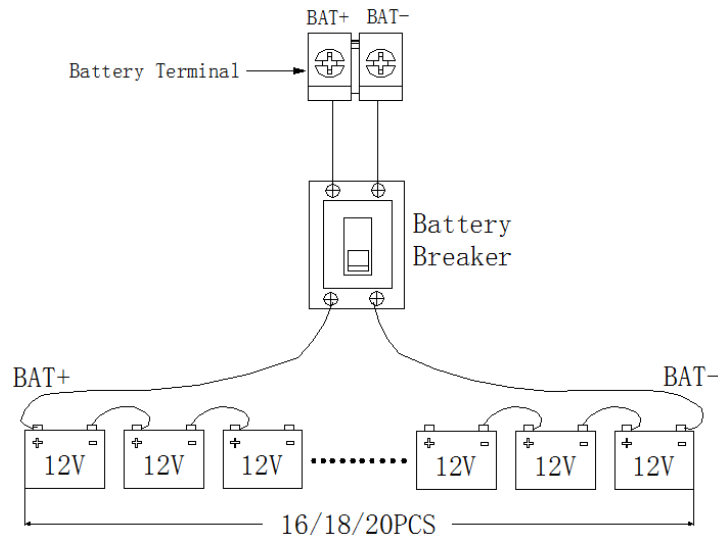

Note:

The BAT+ of the UPS connect poles is connected to the anode of the positive battery, the BAT- is connected to the cathode of the negative battery.

Factory setting of the long-run unit is battery quantity---16pcs, battery capacity---12V7AH (charger current 1A). When connecting 18/20 batteries, please re-set desired battery quantity and its capacity after UPS starts at AC mode. Charger current could be adjusted automatically according to battery capacity selected. All related settings can be done through LCD panel or monitoring software



CAUTION!

Ensure correct polarity battery string series connection. I.e. inter-tier and inter block connections are from (+) to (-) terminals.

Don't mix batteries with different capacity or different brands, or even mix up new and old batteries, either.



WARNING!

Ensure correct polarity of string end connections to the Battery Circuit Breaker and from the Battery Circuit Breaker to the UPS terminals i.e. (+) to (+) / (-) to (-) but disconnect one or more battery cell links in each tier. Do not reconnect these links and do not close the battery circuit breaker unless authorized by the commissioning engineer.

3.9 UPS parallel Installation

The following sections introduce the installation procedures specified to the parallel system.

3.9.1 Cabinet installation

Connect all the UPS needed to be put into parallel system as below picture.

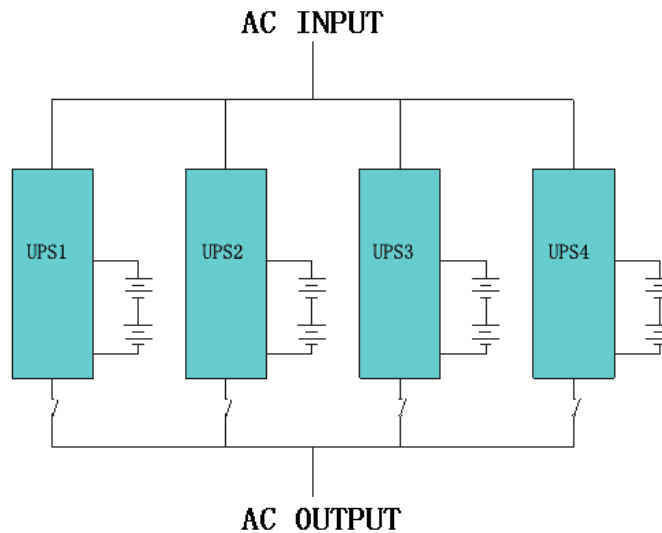

Make sure each UPS input breaker is in "off" position and there is no any output from each UPS connected.



WARNING!

Make sure the L, N lines are correct, and grounding is well connected. Each battery groups of UPS only be connected separately.

3.9.2 Parallel cable installation

Shielded and double insulated control cables available must be interconnected in a ring configuration between UPS units as shown below. The ring configuration ensures high reliability of the control.

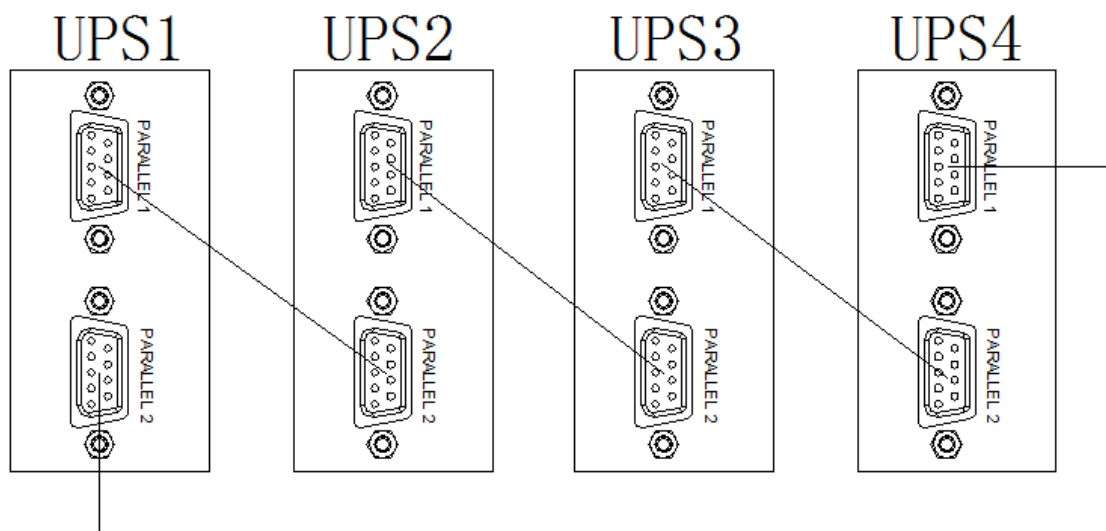

3.9.3 Requirement for the parallel system

A group of paralleled UPS behaves as one large UPS system but with the advantage of presenting higher reliability. In order to assure that all UPS are equally utilized and comply with relevant wiring rules, please follow the requirements below:

- 1) All UPS must be of the same rating and be connected to the same bypass source.
- 2) The outputs of all the UPS must be connected to a common output bus.
- 3) The length and specification of power cables including the bypass input cables and the UPS output cables should be the same. This facilitates load sharing when operating in bypass mode.

3.10 Computer access

- ◆ Download the Kpower software and User Manual from the website in the Kpower User Manual attached to UPS to learn the specific usage method.
- ◆ One end of a USB cable connect to the computer, the other end connect to the USB port on the UPS.
- ◆ Open the software Kpower.
- ◆ KPower adopts a flat design concept, the software concentrates all functions in the same window, the interface is simple and easy to operate. The main interface of the KPower program is shown as follows:

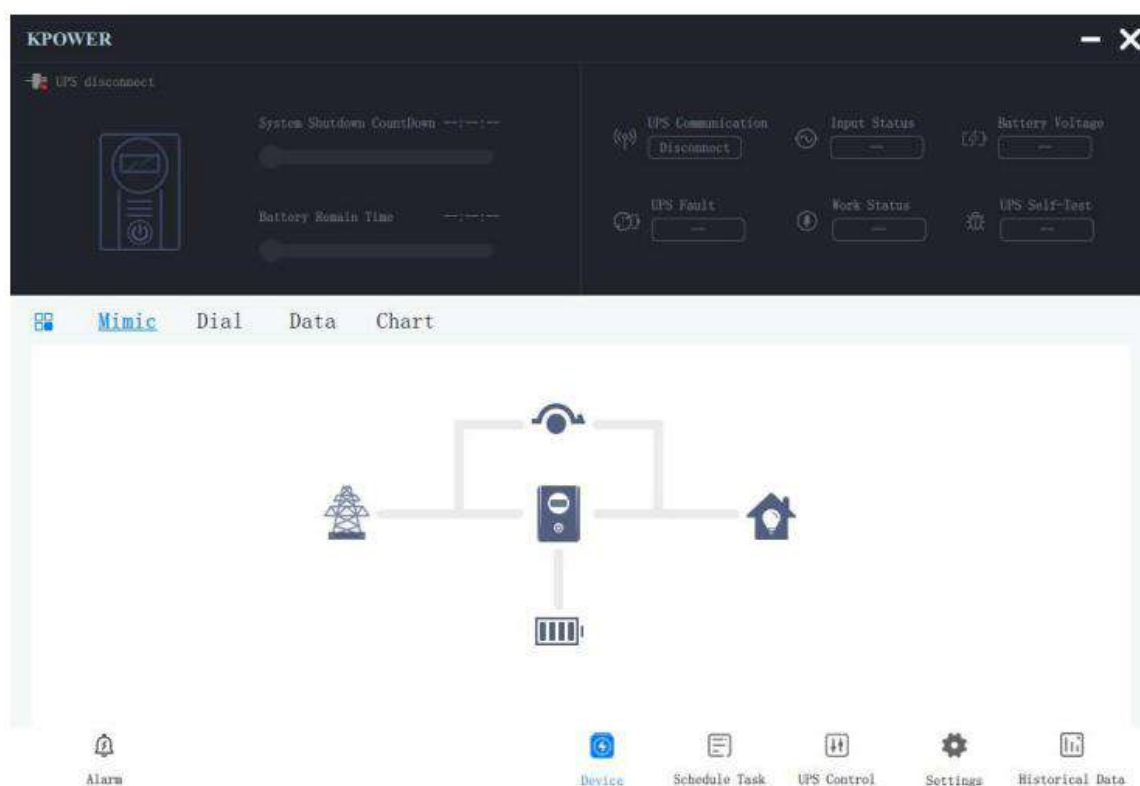

◆ The device page is the main interface of the KPower software. The upper left corner of the page displays the communication connection status with the UPS. When the communication connection is successful, the interface will display that the UPS is connected.

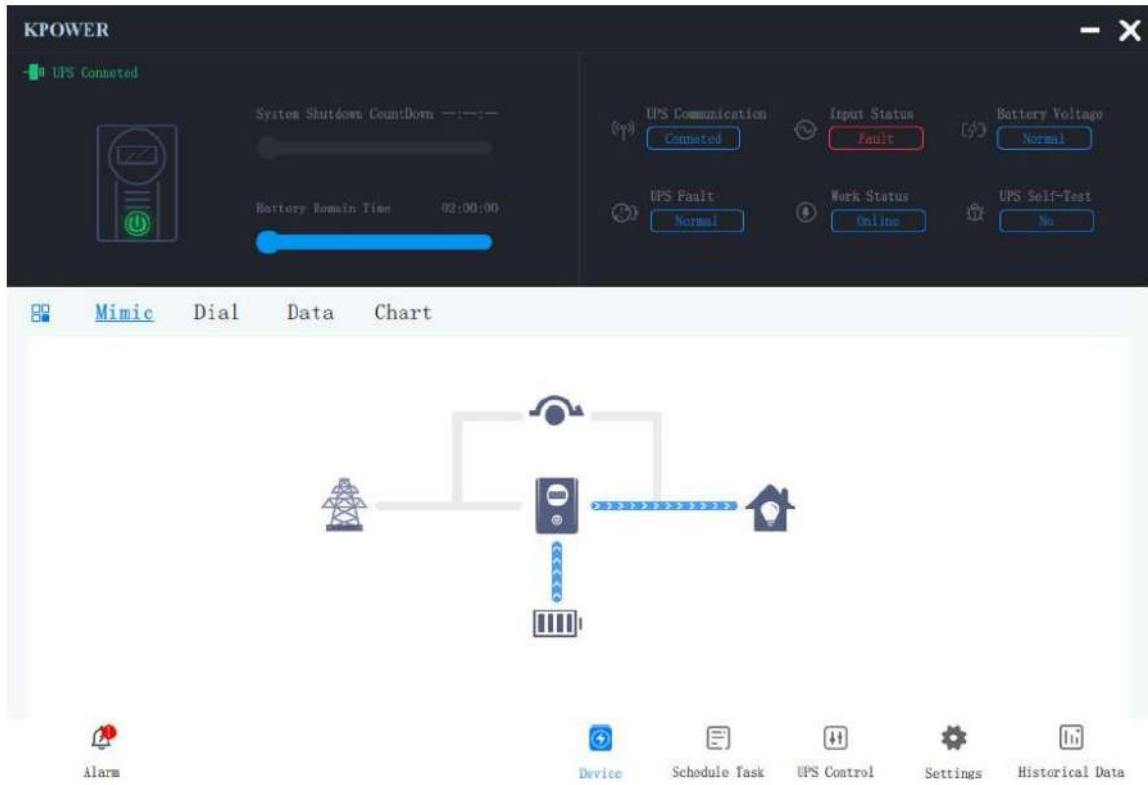

4. Operation

4.1 Operation Modes

The UPS is a double-conversion on-line UPS that may operate in the following alternative modes:

◆Normal mode

The rectifier/charger derives power from the AC Mains and supplies DC power to the inverter while floating and boosting charge the battery simultaneously. Then, the inverter converts the DC power to AC and supplies to the load.

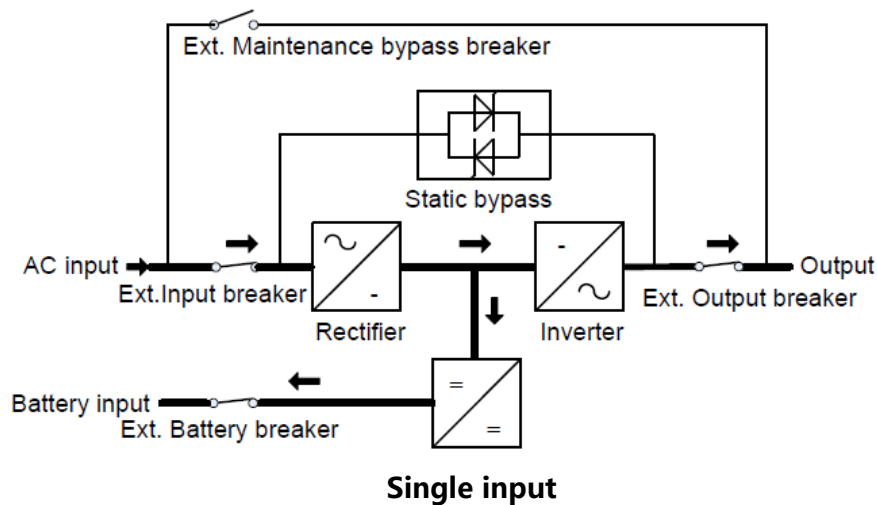

◆Battery mode (Stored Energy Mode)

If the AC mains input power fails, the inverter, which obtains power from the battery, supplies the critical AC load. There is no power interruption to the critical load. The UPS will automatically return to Normal Mode when AC recovers.

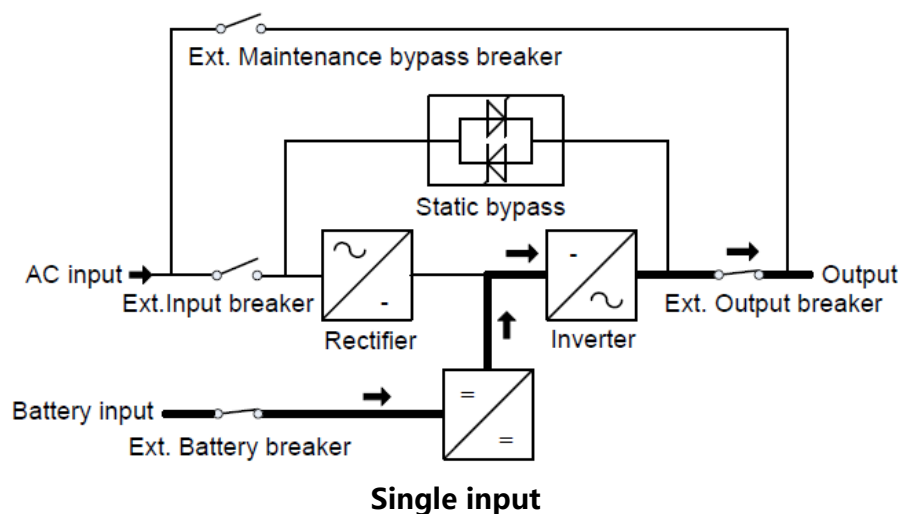

◆ **Bypass mode**

If the inverter is out of order, or if overload occurs, the static transfer switch will be activated to transfer the load from the inverter supply to bypass supply without interruption to the critical load. In the event that the inverter output is not synchronized with the bypass AC source, the static switch will perform a transfer of the load from the inverter to the bypass with power interruption to the critical AC load. This is to avoid paralleling of unsynchronized AC sources. This interruption is programmable but typically set to be less than an electrical cycle e.g. less than 15ms (50Hz) or less than 13.33ms (60Hz).

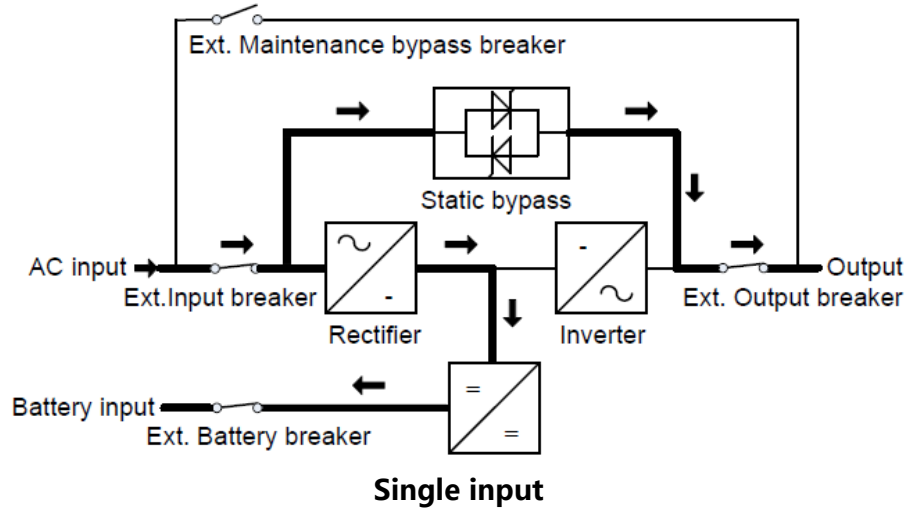

◆ **ECO Mode**

When the UPS is at AC Mode and the requirement to the load is not critical, the UPS can be set at ECO mode in order to increase the efficiency of the power supplied. At ECO mode, the UPS works at Line-interactive mode, so the UPS will transfer to bypass supply. When the AC is out of set window, the UPS will transfer from bypass to Inverter and supplies power from the battery, and then the LCD shows all related information on the screen.

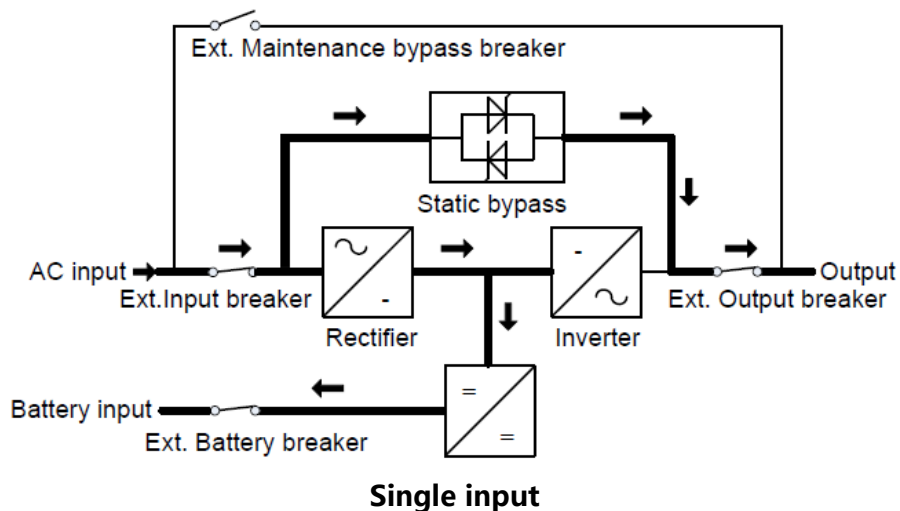

◆ Maintenance mode (Manual Bypass)

A manual bypass switch is available to ensure continuity of supply to the critical load when the UPS is out of order or in repair and this manual bypass switch bears for equivalent rated load.

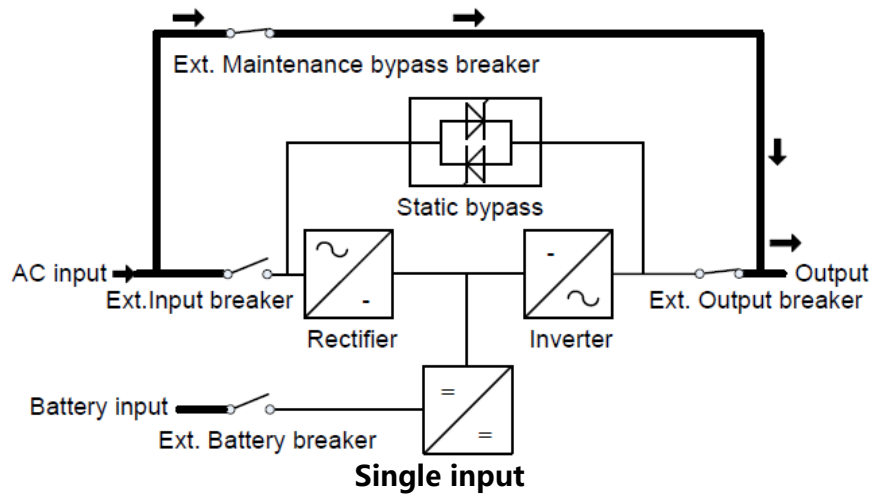

4.2 Turn on/off UPS

4.2.1 Restart procedure



CAUTION!

MAKE SURE GROUNDING IS PROPERLY DONE!

- ◆ Set the Battery Breaker to the "ON" position according to the user's manual.



CAUTION!

Check to see if the load is safely connected with the output of the UPS. If the load is not ready to receive power from the UPS, make sure that it is safely isolated from the UPS output terminals

- ◆ Turn ON OUTPUT breaker.
- ◆ Turn ON INPUT breaker.

If the Rectifier input is within voltage range, the rectifier will start up in 30 seconds then the inverter will start up after then.

If the rectifier fails at startup, the bypass LED will light up. When the inverter starts up, the UPS will transfer from bypass mode to inverter mode, then the bypass LED extinguishes and the inverter LED lights up.

No matter whether the UPS can work normally or not, all the status will be shown on the LCD display.

4.2.2 Test procedure



CAUTION!

The UPS is operating normally. It may take 60 seconds to boost up the system and perform self-test completely.

- ◆ Switch OFF INPUT breaker to simulate utility failure, the rectifier will turn off and the battery should feed the inverter without interruption. At this time, the LEDs of battery should be turned on.
- ◆ Turn ON INPUT breaker to simulate utility recovery, the rectifier will restart automatically after 20 seconds and the inverter will supply to the load. It is suggested to use Dummy loads for testing. The UPS can be loaded up to its maximum capacity during load test.

4.2.3 MAINTENANCE BYPASS

To supply the load via Mains, you may simply active the internal mechanical bypass switch.



CAUTION!

The load is not protected by the UPS when the internal mechanical bypass system is active and the power is not conditioned.

Switch to mechanical bypass



CAUTION!

If the UPS is running normally and can be controlled through the display, please perform the following steps:

- ◆ Open the cover of MAINTENANCE breaker, the UPS turns to bypass mode automatically.
- ◆ Turn ON MAINTENANCE breaker;
- ◆ Switch OFF BATTERY breaker;
- ◆ Switch OFF INPUT breaker;
- ◆ Switch OFF OUTPUT breaker;

At this time the input source will supply to the load through the MAINTENANCE breaker.

Switch to normal operation (from mechanical bypass)



CAUTION!

Never attempt to switch the UPS back to normal operation until you have verified that there are no internal UPS faults.

- ◆ Turn ON INPUT breaker.
- ◆ Turn ON BATTERY breaker.

The UPS powers from the static bypass instead of the maintenance bypass, then the bypass LED will light up.

- ◆ Turn ON OUTPUT breaker.
- ◆ Switch OFF the MAINTENANCE breaker, then the output is supplied by the static bypass of the UPS.
- ◆ Put on the cover of MAINTENANCE breaker.

The rectifier will operate normally after 30 seconds. If the inverter works normally, the system will be transferred from bypass mode to normal mode.

4.2.4 Cold start procedure

CAUTION!



UPS can cold-start when the input AC Utility Failure, but battery is normal. Follow these procedures.

- ◆ Turn ON the BATTERY breaker.
 The battery will feed the Auxiliary power.
- ◆ Turn ON the OUTPUT breaker.
- ◆ Trigger the cold start(Cold start) button as the position 1 below drawing.

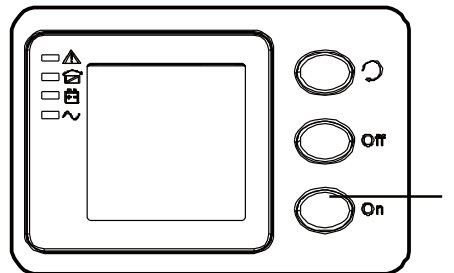

When battery normal, rectifier starts operation, 30s later, inverter starts and operates and battery LED on.

4.2.5 Shut down procedure

CAUTION!



This procedure should be followed to completely shut down the UPS and the LOAD. After all power switches, isolators and circuit breakers are opened, there will be no output.

- ◆ Switch OFF the BATTERY breaker;
- ◆ Switch OFF the INPUT breaker.

- ◆ Switch OFF the OUTPUT breaker. The UPS shuts down;
- ◆ To completely isolate the UPS from AC input, all input switches of Utility shall be completely off, which includes the ones for rectifier and bypass.
- ◆ The primary input distribution panel, which is often located far away from the UPS area, so a label should be posted to advise service personnel that the UPS circuit is under maintenance.

WARNING!



Wait for about 40 minutes for the internal D.C. bus bar capacitors to be completely discharged.

4.3 The LCD Display

4.3.1 LCD Display Information

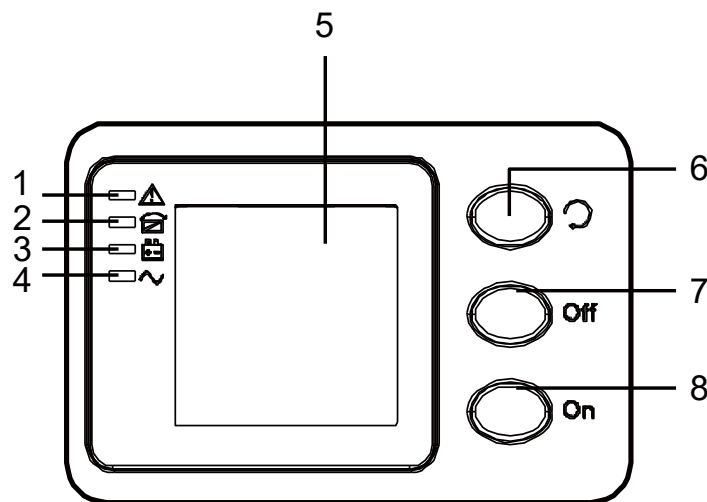

Overview of the operating panel of the UPS

- (1) ALARM LED
- (2) BYPASS LED
- (3) BATTERY LED
- (4) INVERTER LED
- (5) LCD display
- (6) Scroll button: enter to next item
- (7) OFF button
- (8) ON button

4.3.2 LCD display

NOTICE! The display provides more functions than those described in this manual. There are 9 interfaces available in the LCD display:

ITEM	Interface Description	Content Displayed
01	Input	Voltage & Frequency
02	Bat.	Voltage & Current
03	Output	Voltage & Frequency
04	Load	Load
05	Temperature	PFC/Internal temperature and ambient temperature
06	CODE	Alarm Code (Warning Message)
07	Software version & model	DSP version of inverter software, model
08	Bus voltage	Bus voltage \pm
09	CODE	Operational Status and Mode

1. When the UPS is connecting with the Utility or Battery at cold start mode, it shows as drawing below:

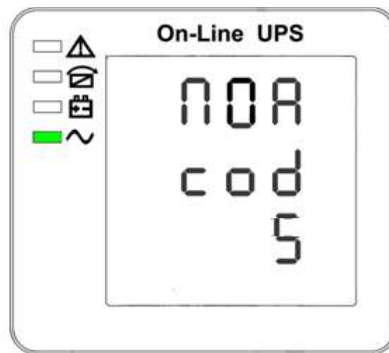

(1) Operational Status and mode

1) Operational Status and mode When the UPS at single mode, it shows "NOA" or "ECO", but If the UPS at parallel mode, it shows "PAL" instead.

2) Press "scroll" button, the UPS goes to next page as shown below.

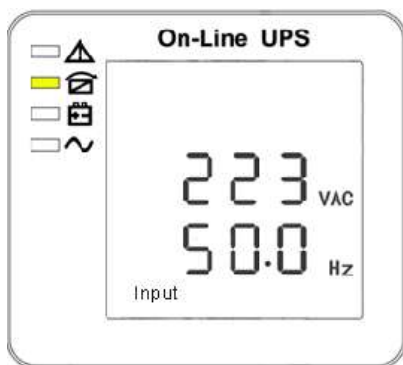

(2) Input voltage



(3) Bat voltage

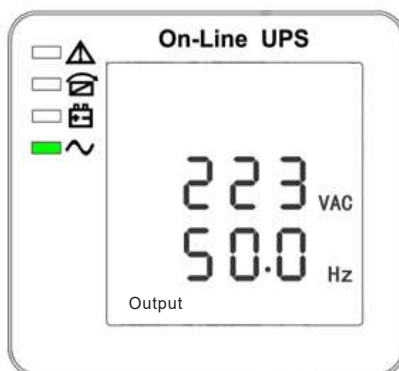

(4) Output voltage

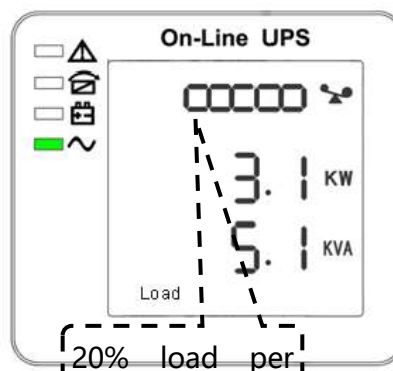

(5) Load

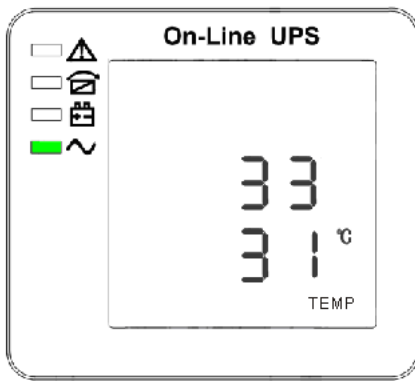

(6) Radiator temperature (up),
 Ambient temperature (down)

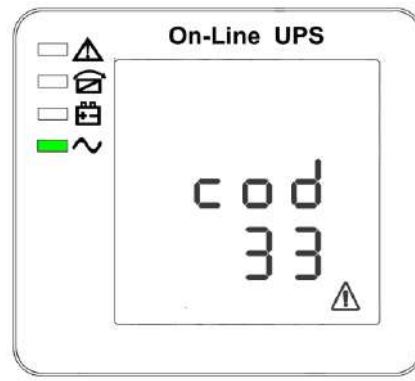

(7) Alarm Code

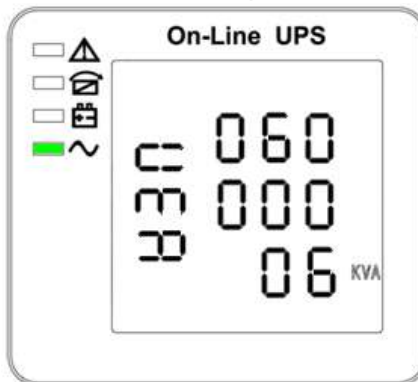

(8) Software version & model

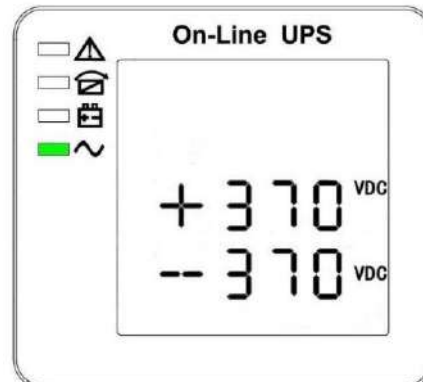

(9) Bus voltage

1. If some of above interfaces have battery charging, it will display the charging information at the same time as shown below.

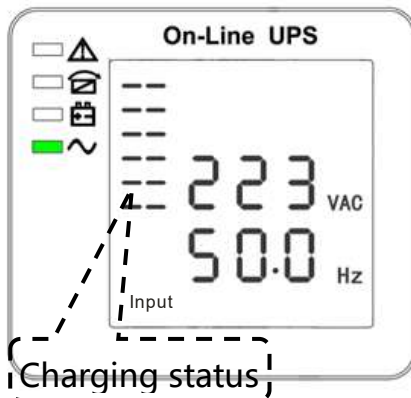

Boost

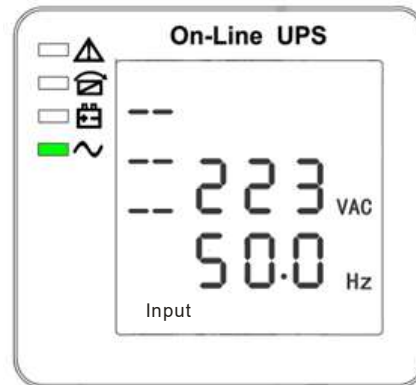

Floating

2. Pressing "scroll" button, you may circulate all messages from the first one to the last one then returns back to the first one and vice versa.

3. All alarm codes are present when abnormal behavior(s) occur(s).

The display value of the above parameter will update within 0.2s.

4.4 Parameters setting

The setting function is controlled by 3 buttons (Enter ◁, Off ▲, On ▼): Enter ◁---goes into the setting page and value adjustment; Off ▲ & On ▼---for choosing different pages.

After the UPS turn ON, press buttons ◁ & ▲ for 3 seconds and then goes into the setting interface page. After finishing setting the parameter, press "ON" until exiting out of the current interface.

Note: Figure at left corner is the page number of the setting pages. After entering the setting interface, it will exit when without operation in 30s.

4.4.1 Mode setting

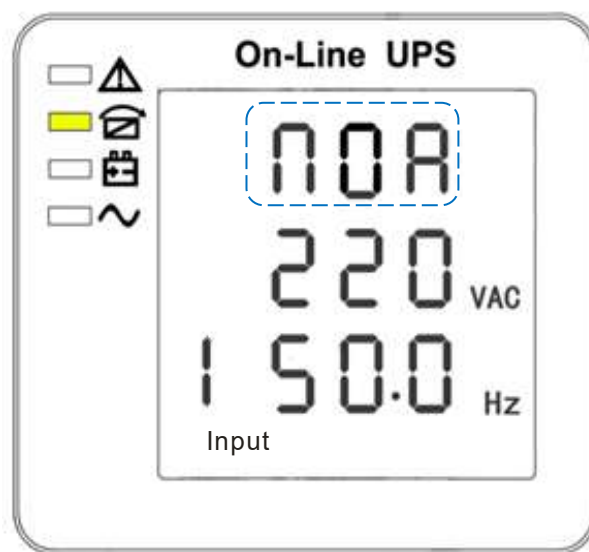

Mode setting (Note: Inside the broken-line is the flashing part.)

After entering the setting menu, it' s mode setting defaulted, and the mode setting line flashing as in above picture.

- Use button Enter ◁ to choose different mode. There are 3 different modes for setting: ECO, PAL, NOR.
- Press ▲ or ▼ to exit the mode setting (save the mode setting), and goes to output voltage setting or parallel redundancy quantity.

4.4.2 Output voltage class setting

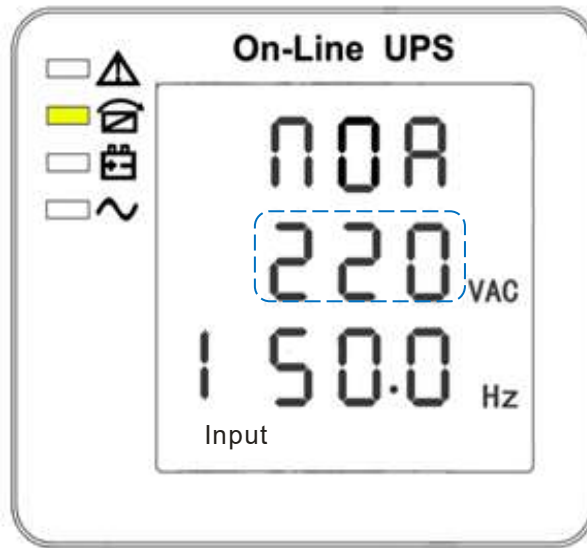

Output voltage setting
 (Note: Inside the broken-line is the flashing part.)

When under the mode setting press On▼ or when under frequency setting press Off▲, it goes to the output voltage setting. The output voltage line flashes as in above picture.

- Use button Enter↵ to choose the different output voltage. There are 4 different voltages--- 208,220, 230, 240.
- Press▲ or ▼ to exit the output voltage setting (save the output voltage setting) and goes to mode setting or frequency setting.

NOTE: When powered by inverter, it is necessary to turn off the inverter before setting voltage and frequency level.

4.4.3 Output frequency class setting

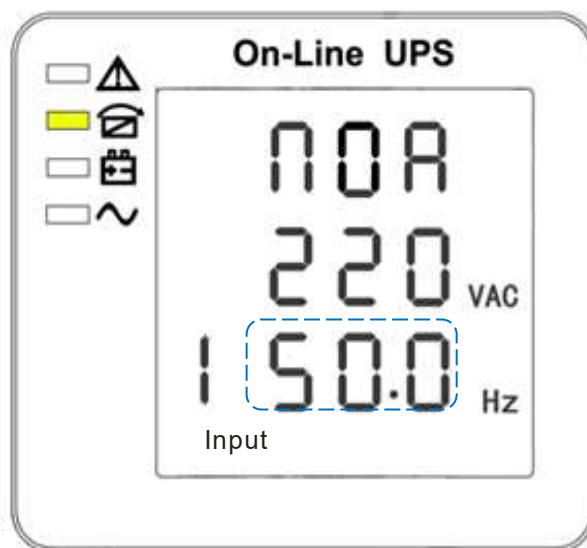

Frequency setting
 (Note: Inside the broken-line is the flashing part.)

When under the output voltage setting press On▼ or when under battery capacity setting press Off▲, it goes to the frequency setting. The frequency line flashes as in above picture.

- Use button Enter↵ to choose the different frequency. There are 2 different frequency--- 50/60Hz.
- Press▲ or ▼ to exit the frequency setting (save the frequency setting) and goes to output voltage setting or battery capacity setting.

Note: When powered by inverter, it is necessary to turn off the inverter before setting voltage and frequency level.

4.4.4 Battery capacity setting

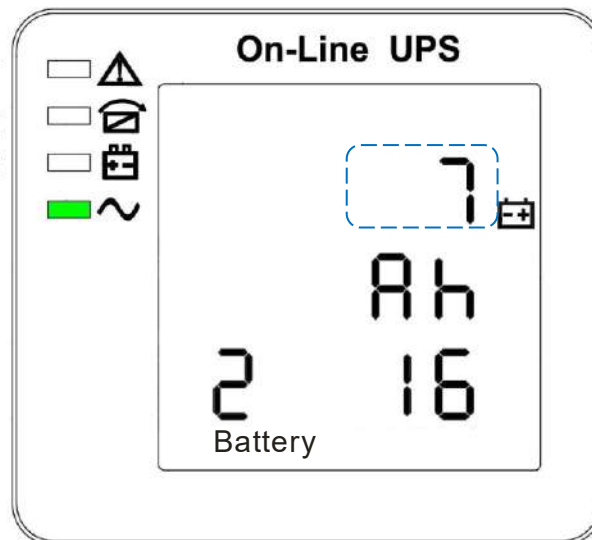

Battery capacity setting
 (Note: Inside the broken-line is the flashing part.)

When under the frequency setting press On▼ or when under battery quantity setting press Off▲, it goes to the battery capacity setting. The battery capacity line flashes as in above picture.

- Use button Enter↵ to choose the different battery capacity. Battery capacity range is 5-200Ah. (Note: long-press of Enter ↵ can adjustment battery capacity quickly.)
- Press▲ or ▼ to exit the battery capacity setting (save the capacity setting) and goes to frequency setting or battery quantity setting.

4.4.5 Battery quantity setting

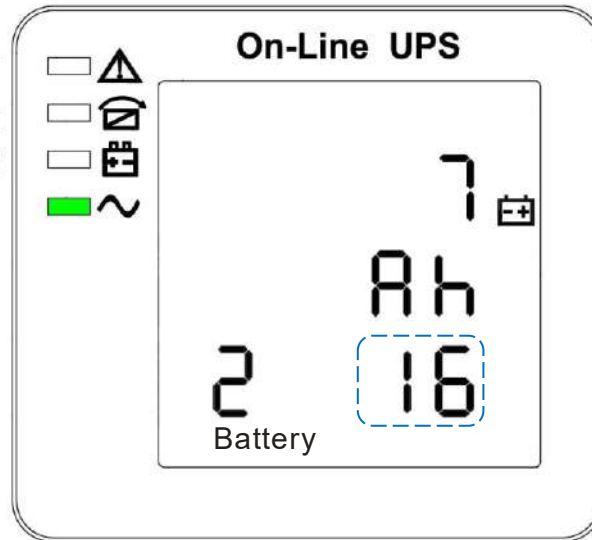

Battery quantity setting
 (Note: Inside the broken-line is the flashing part.)

When under the battery capacity setting press On▼ or when under bypass voltage upper limit setting press Off▲, it goes to the battery quantity setting. The battery quantity line flashes as in above picture.

- Use button Enter↵ to choose the different battery quantity. Battery quantity range is 16, 18, 20.
- Press ▲ or ▼ to exit the battery quantity setting (save the battery quantity setting) and goes to battery capacity setting or bypass voltage upper limit setting.

4.4.6 Bypass Volt-Hi setting

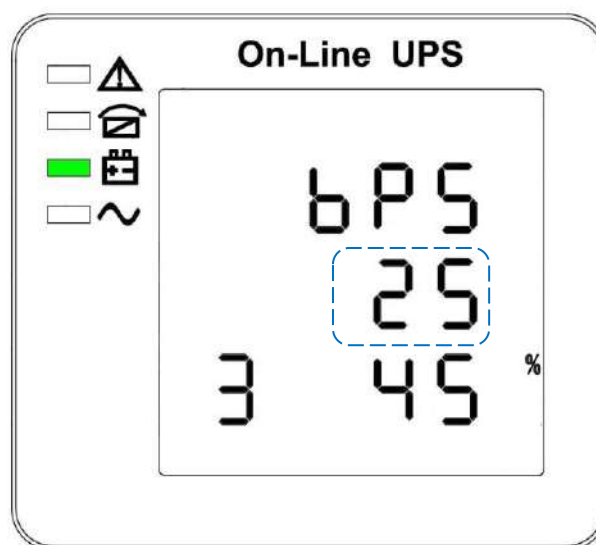

Bypass voltage upper limit setting
 (Note: Inside the broken-line is the flashing part.)

When under the battery quantity setting press On▼ or when under bypass voltage lower setting press Off▲, it goes to the bypass upper limit setting. The bypass upper limit line flashes as in above picture.

- Use button Enter↵ to set the different bypass voltage upper limit. The bypass voltage upper limit range is 10%,15%, 20%, 25%.
- Press▲ or ▼ to exit the bypass voltage upper limit setting (save the bypass voltage upper limit setting) and goes to battery quantity setting or bypass voltage lower limit setting.

4.4.7 Bypass Volt-Lo setting

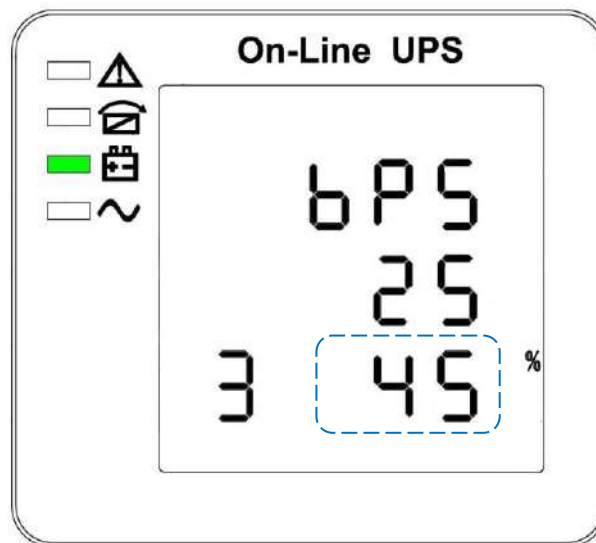

Bypass voltage lower limit setting
 (Note: Inside the broken-line is the flashing part.)

When under the bypass voltage upper limit setting press On▼ or when under parallel ID setting press Off▲, it goes to the bypass lower limit setting. The bypass lower limit line flashes as in above picture. ("-" for negative, positive does not have any symbol.)

- Use button Enter (to set the different bypass voltage lower limit. The bypass voltage lower limit range is 10%,20%,30%,45%.
- Press▲ or ▼ to exit the bypass voltage lower limit setting (save the bypass voltage lower limit setting) and goes to bypass upper limit setting or parallel ID setting.

4.4.8 Buzzer Mute Setting

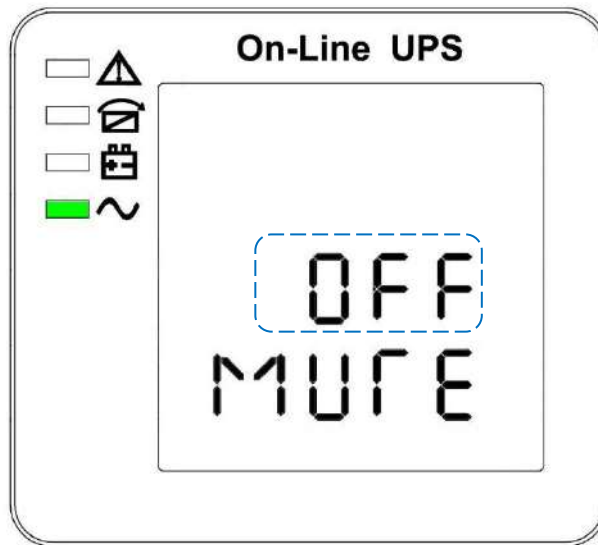

Buzzers mute setting (Note: flashing part in dashed box)

Press ON under bypass voltage lower limit setting or press OFF under the parallel ID setting can enter the buzzer setting. Now the setting status is flashing as the Figure shows (note: on=mute; off=no mute). When press, it shows the mute cycle setting, the selection includes ON and OFF. (Press the up button or down button can exit the mute setting (save the mute setting status) and switch to bypass voltage lower limit setting or Battery self-test setting (note: when in stand-alone mode, press down button to exit and save the settings, then the settings is completed for stand-alone unit).

4.4.9 Battery Test Setting

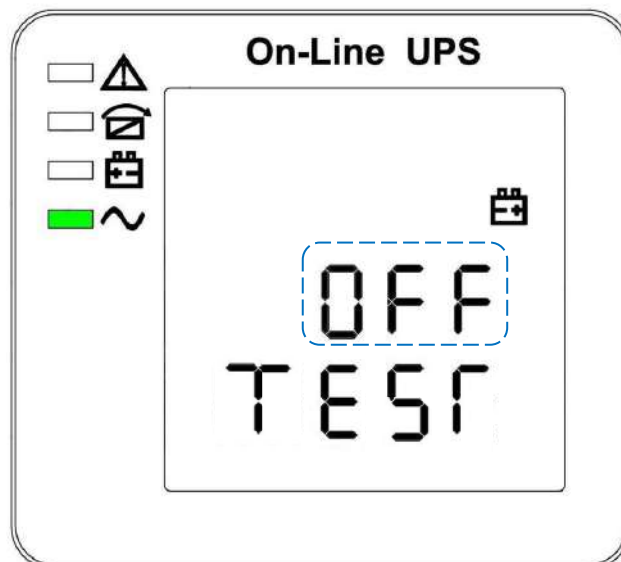

Battery self-test setting

This page is the introduction to the Battery self-test setting. The default Settings is "OFF" when the UPS has no need of the battery self-test function. When turn to "ON" , batteries can do the self-test automatically per 30 days. Three kinds of Battery Self-test Time can be chose as below.

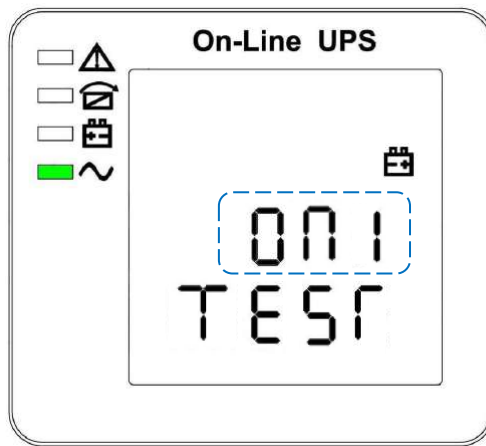

When choosing On1, UPS can transfer to Battery Mode automatically per 30 days. And the Battery Self-test Time is 10 seconds.

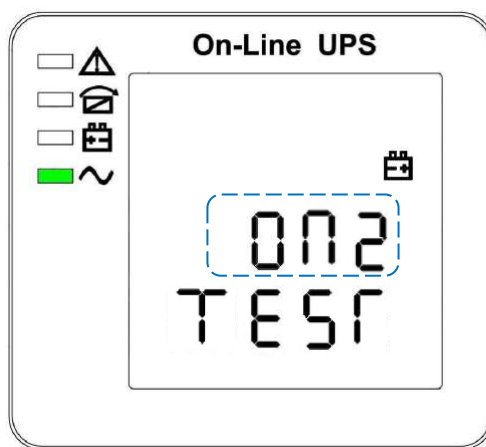

When choosing On2, UPS can transfer to Battery Mode automatically per 30 days. And the Battery Self-test Time is 10 minutes.

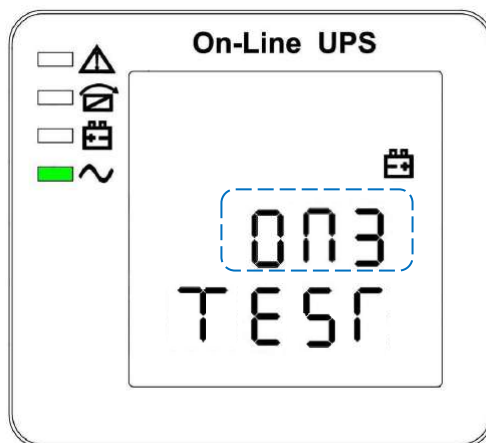

When choosing On3, UPS can transfer to Battery Mode automatically per 30 days. And the Battery Self-test Time is EOD.

4.4.10 Parallel ID setting

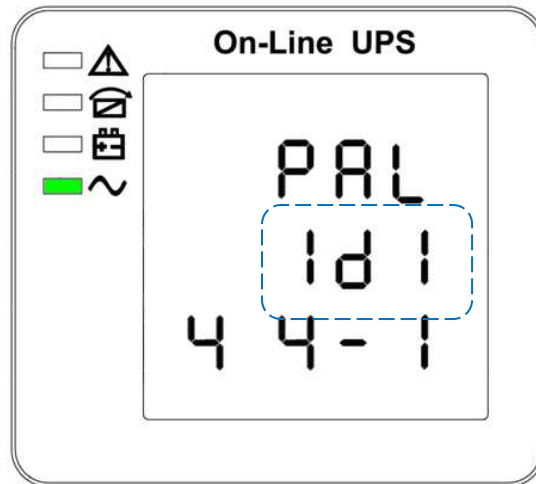

Parallel ID setting

(Note: Inside the broken-line is the flashing part.)

When under the bypass voltage lower limit setting press On▼ or when under parallel quantity setting press Off▲, it goes to the parallel ID setting. The parallel ID flashes as in above picture.

- Use button Enter↵ to set the different parallel ID. The parallel ID range is 1~4.
- Press▲ or ▼ to exit the parallel ID setting (save the parallel ID setting) and goes to bypass lower limit setting or parallel quantity setting.

NOTICE! Parallel cable cannot be connected when setting the parallel parameters.

4.4.11 Parallel quantity setting

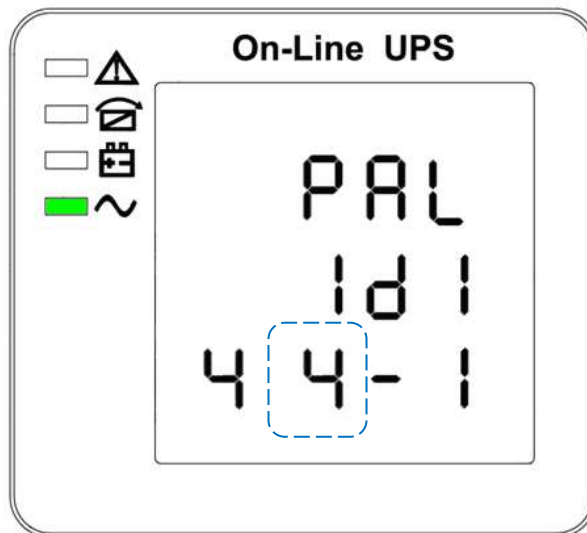

Parallel quantity setting

(Note: Inside the broken-line is the flashing part.)

When under the parallel ID setting press On▼ or when under parallel redundancy quantity setting press Off▲, it goes to the parallel quantity setting. The parallel quantity flashes as in above picture.

- Use button Enter↵ to set the parallel quantity. The parallel quantity range is 2~4.
- Press▲ or ▼ to exit the parallel quantity setting (save the parallel quantity setting) and goes to parallel ID setting or parallel redundancy quantity setting.

4.4.12 Parallel redundancy quantity setting

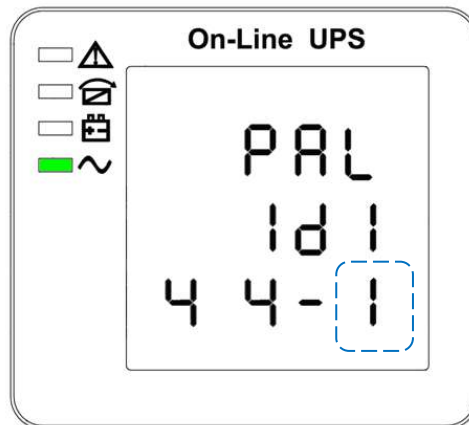

Parallel redundancy quantity setting

(Note: Inside the broken-line is the flashing part.)

When under the parallel quantity setting press On▼, it goes to the parallel redundancy quantity setting. The parallel redundancy quantity flashes as in above picture.

- Use button Enter↵ to set the parallel redundancy quantity. The parallel redundancy quantity range is 0~3
- Press▲ to go to parallel quantity setting, or ▼ to exit the mode setting. Then UPS LCD panel setting is accomplished.

4.5 Display Messages/ Records

This section lists the event and alarm messages that the UPS might display. The messages are listed in alphabetical order. This section is listed with each alarm message to help you troubleshoot problems .

4.5.1 Operational Status and Mode(s)

Note: "X" shows that it will determined by other conditions.

item	Content Displayed	LED			
		Fault	Bypass	Battery	Inverter
1	Initialized	EXTINGUISH	EXTINGUISH	EXTINGUISH	EXTINGUISH
2	Standby Mode	EXTINGUISH	EXTINGUISH	X	EXTINGUISH
3	No Output	EXTINGUISH	EXTINGUISH	X	EXTINGUISH
4	Bypass Mode	EXTINGUISH	LIGHT	X	EXTINGUISH
5	Utility Mode	EXTINGUISH	EXTINGUISH	X	LIGHT
6	Battery Mode	EXTINGUISH	EXTINGUISH	LIGHT	EXTINGUISH
7	Battery Self-diagnostics	EXTINGUISH	EXTINGUISH	LIGHT	EXTINGUISH
8	Inverter is starting up	EXTINGUISH	X	X	EXTINGUISH
9	ECO Mode	EXTINGUISH	X	X	X
10	EPO Mode	LIGHT	EXTINGUISH	X	EXTINGUISH
11	Maintenance Bypass Mode	EXTINGUISH	EXTINGUISH	EXTINGUISH	EXTINGUISH
12	Fault Mode	LIGHT	X	X	X

4.5.2 Alarm Information

Item	UPS Alarm Warning	Buzz	LED
1	Rectifier Fault	Beep continuously	Fault LED lit
2	Inverter fault(Including Inverter bridge is shorted)	Beep continuously	Fault LED lit
3	Inverter Thyristor short	Beep continuously	Fault LED lit
4	Inverter Thyristor broken	Beep continuously	Fault LED lit
5	Bypass Thyristor short	Beep continuously	Fault LED lit
6	Bypass Thyristor broken	Beep continuously	Fault LED lit
7	Fuse broken	Beep continuously	Fault LED lit
8	Parallel relay fault	Beep continuously	Fault LED lit
9	Fan fault	Beep continuously	Fault LED lit
10	Reserve	Beep continuously	Fault LED lit
11	Auxiliary power fault	Beep continuously	Fault LED lit
12	Initialization fault	Beep continuously	Fault LED lit
13	P-Battery Charger fault	Beep continuously	Fault LED lit
14	N-Battery Charger fault	Beep continuously	Fault LED lit
15	DC Bus over voltage	Beep continuously	Fault LED lit
16	DC Bus below voltage	Beep continuously	Fault LED lit
17	DC bus unbalance	Beep continuously	Fault LED lit
18	Soft start failed	Beep continuously	Fault LED lit
19	Rectifier Over Temperature	Twice per second	Fault LED lit
20	Inverter Over temperature	Twice per second	Fault LED lit
21	Reserve	Twice per second	Fault LED lit
22	Battery reverse	Twice per second	Fault LED lit
23	Cable connection error	Twice per second	Fault LED lit
24	CAN comm. Fault	Twice per second	Fault LED lit
25	Parallel load sharing fault	Twice per second	Fault LED lit
26	Battery over voltage	Once per second	Fault LED blinking
27	Mains Site Wiring Fault	Once per second	Fault LED blinking
28	Bypass Site Wiring Fault	Once per second	Fault LED blinking
29	Output Short-circuit	Once per second	Fault LED blinking
30	Rectifier over current	Once per second	Fault LED blinking
31	Bypass over current	Once per second	BPS LED blinking
32	Overload	Once per second	INV or BPS blinking
33	No battery	Once per second	BATTERY blinking
34	Battery under voltage	Once per second	BATTERY blinking
35	Battery low pre-warning	Once per second	BATTERY blinking
36	Overload Delay	Once per second	Bypass LED blinking
37	DC component over limit.	Once per 2 seconds	INV blinking
38	Parallel Overload	Once per 2 seconds	INV blinking
39	Mains volt. Abnormal	Once per 2 seconds	BATTERY LED lit

Item	UPS Alarm Warning	Buzz	LED
40	Mains freq. abnormal	Once per 2 seconds	BATTERY LED lit
41	Bypass Not Available		BPS blinking
42	Bypass unable to trace		BPS blinking
43	Inverter on invalid		
44	Reserve		
45	EPO active	Beep continuously	Fault LED lit
46	PDU active		Bypass LED lit
47	Transformer Over Temperature	Beep continuously	Fault LED lit

4.6 Options

SNMP card: SNMP / mini SNMP optional

- ◆ Loosen the 2 torque screws (on each side of the card).
- ◆ Carefully pull out the card. Reverse the procedure for re-installation

The slot called SNMP supports the MEGAtec protocol. SNMP card port is also a tool to remotely monitor and manage any UPS system

SNMP card supports the Modem Dial-in (PPP) function to enable the remote control via the internet when the network is unavailable.

In addition to the features of a standard SNMP card, SNMP card has the option to add NetFeeler Lite to detect temperature, humidity, smoke and security sensors. Thus, making SNMP card a versatile management tool. SNMP card also supports multiple languages and is setup for web-based auto language detection.

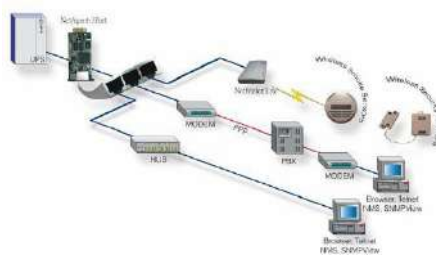

Typical topology of the UPS Network Management

Relay card

A 10-pin terminal is supported to offer the signals of Bypass, Utility Failure, Inverter On, Battery Low, UPS fault, UPS Alarm, and UPS Shutdown.

The relay communication card contains six dry contact outputs and one dry input. The inputs and outputs are factory programmed according to functions listed in the table

Table: Relay Contacts (communication card)



Pin	Function Description	Input or Output
1	Utility Failure	Output
2	Battery Low	
3		
4	Bypass On	
5	UPS Fault	
6	Inverter On	
7	Summary Alarm	
8	common	
9	Remote Shutdown +	Input (5~12V)
10	Remote Shutdown -	

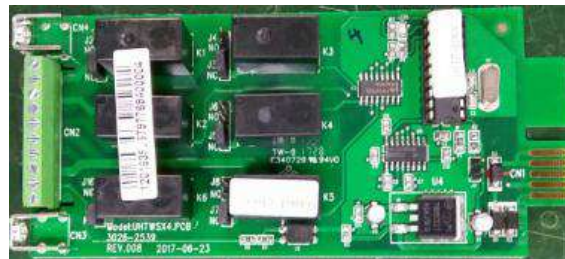

Appendix 1 Specifications

GENERAL		
Capacity	6kVA / 6kW	10kVA / 10kW
Topology	Double Conversion On-Line	
Cooling	Fan cooled	
Dimension W x D x H (mm)	250*643*715mm (With wheel)	
Installation Type	Tower	
INPUT		
Nominal voltage	208/220/230(Default)/240Vac	
Input Voltage Range	110-300Vac(110-300Vac @ 50% load / 176-300Vac @ 100% load)	
Frequency Range	40-70Hz	
Harmonic distortion(THDi)	< 3%	
Power Factor	>0.99	
Input Connection	Terminal(L+N+G)	
OUTPUT		
Output Power	6kW	10kW
Power factor	1.0	
Output Waveform	Pure Sinewave	
Online Efficiency (up to)	95.0%	95.5%
Economy mode efficiency	98.8%	99%
Output voltage	208/220/230(Default)/240Vac	
Voltage Regulation	±1%	
Output Voltage Regulation (Dynamic)	±5%	
Harmonic distortion(THDv)	< 1% (Full Linear load)	
	< 3% (Full nonlinear load)	
Output Frequency	50/60Hz ± 10%(Line mode); 50/60Hz(default) ±0.1%(Battery mode)	
Over Load Capability (Online mode)	105%~110%: UPS transfer to bypass after 60 minutes when the utility is normal 110%~125%: UPS transfer to bypass after 10 minutes when the utility is normal 125%~150%: UPS transfer to bypass after 1 minute when the utility is normal >150%: UPS transfer to bypass after 0.5 second when the utility is normal	
Over Load Capability (Battery mode)	105%~110%: UPS after 10 minute shut down 110%~125%: UPS after 1 minute shut down 125%~150%: UPS after 10 second shut down >150%: UPS after 0.5 second shut down	
Over Load Capability (Bypass mode)	105%~130%: Only Overload alarm 130%~150%: UPS after 10 minute shut down 150%~200%: UPS after 1 minute shut down >200%: after 0.5 second shut down	
	Breaker 40A	Breaker 63A
Current Crest Ratio	3:1	
Output Connection	Terminal (L+N+G)	

BYPASS		
Voltage range	208/220Vac Max.voltage: +25% (optional +10%,+15%,+20%) 230Vac Max.voltage: +20% (optional +10%,+15%) 240Vac Max.voltage: +15% (optional +10%) Min. voltage: -45% (optional -10%,-20%,-30%)	
Frequency range	Frequency Protection Range: ±10%	
ECO Range	Rated Voltage ± 10%	
BATTERY		
Capacity (Standard unit)	7Ah/12V (9Ah/12V optional)	9Ah/12V (7Ah/12V optional)
Nominal DC Voltage	Standard Unit	216Vdc
Charge Current (max.)	8A	10A
Communication Section and User Interface		
Control panel LCD (English-Language)+LED	Segment code screen	
Communication Interface	USB,RS232,RS485 port, Intelligent slot, Parallel port (optional), SNMP card (optional), Relay card (optional)	
Emergency Power Off (EPO)	Yes	
ENVIRONMENT		
Operating temperature	0°C~40°C	
Storage temperature	-25°C~55°C (without batteries)	
Humidity range	0~95%RH (Non -condensing)	
Operating altitude	0~1000 meters Normally operate; 1000~3000 meters Derating	
Protection Class	IP20	
Noise level (1m, Online mode, full load, float charging)	≤45dB	≤50dB
STANDARDS		
Safety	EN IEC 62040-1:2019 + A11:2021	
EMC	IEC 62040-2:2016, EN IEC 62040-2:2018	
OTHERS		
Generator Compatible	Yes	
Short Circuit	Hold Whole System	
Overheat	Line Mode: Switch to Bypass; Backup Mode: Shut down UPS immediately	
Low battery voltage	Alarm and Switch off	
EPO	Shut down UPS immediately	
Audible & Visual alarms	Line Failure, Battery Low, Overload, System Fault	

Appendix 2 Problems and Solution

In case the UPS cannot work normally, it might be wrong in installation, wiring or operation. Please check these aspects first. If all these aspects are checked without any problem, please consult with local agent right away and provide below information.

(1) Product model name and serial number.

(2) Try to describe the fault with more details, such as LCD display info, LED lights status, etc.

Read the user manual carefully, it can help a lot for using this UPS in the right way. Some FAQ (frequently asked questions) may help you to troubleshoot your problem easily.

No.	Problem	Possible reason	Solution
1	Utility is connected but the UPS cannot be powered ON.	Input power supply is not connected; Input voltage low; The input switch of the UPS is not switched on.	Measure if the UPS input voltage/frequency is within the window. Check if UPS input is switched on
2	Utility normal but Utility LED does not light on, and the UPS operates at battery mode	The input breakers of the UPS are not switched on; input cable is not well connected	Switch on the input breaker; Make sure the input cable is well connected.
3	The UPS does not indicate any failure, but output do not have voltage	Output cable does not well connected; Output breaker do not switch on	Make sure the output cable is well connected; Switch on the output breaker.
4	Utility LED is flashing	Utility voltage exceeds UPS input range.	If the UPS operates at battery mode, please pay attention to the remaining backup time needed for your system.
5	Battery LED is flashing but no charge voltage and current	Battery breaker does not switch on, or batteries are damaged, or battery is reversely connected. Battery number and capacity are not set correctly.	Switch on the battery breaker. If batteries are damaged, need to replace whole group batteries, Connect the battery cables correctly; Go to LCD setting of the battery number and capacity, set the correct data.
6	Buzzer beeps every 0.5 seconds and LCD display "output overload"	Overload	Remove some load
7	The UPS only works on bypass mode	The UPS is set to ECO mode, or the transfer times to bypass mode are limited.	Set the UPS working mode to UPS type(non-parallel) or to reset the times of transferring to bypass or re-start the UPS
8	Cannot Cold-start	Battery switch is not properly closed: Battery fuse is blown Or Battery low: Battery quantity set wrong;	Close the battery switch: Replace the fuse: Recharge the battery: Power ON the UPS with AC to set the battery quantity & quantity;

Appendix 3 USB communication port definition

Definition of port:

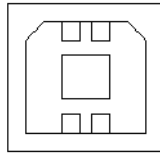

Connection between PC USB port and UPS USB port.

PC USB port	UPS USB port	Description
Pin 1	Pin 1	PC : +5V
Pin 2	Pin 2	PC : DPLUS signal
Pin 3	Pin 3	PC : DMINUS signal
Pin 4	Pin 4	Signal ground

Available function of USB

- ◆ Monitor UPS power status.
- ◆ Monitor UPS alarm info.
- ◆ Monitor UPS running parameters.
- ◆ Timing off/on setting.

Communication data format

Baud rate ----- 9600bps

Byte length ----- 8bit

End bit ----- 1bit

Parity check -----none



CAUTION!

USB, RS232 and RS485 interface cannot be used at the same time, you can only use one of them at one time.

Appendix 4 RS232 communication port definition

Definition of Male port:

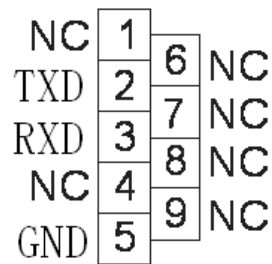

Connection between PC RS232 port and UPS RS232 port

PC RS232 port	UPS RS232 port	
Pin 2	Pin 2	UPS send,PC receive
Pin 3	Pin 3	PC send,UPS receive
Pin 5	Pin 5	ground

Available function of RS232

- ◆ Monitor UPS power status.
- ◆ Monitor UPS alarm info.
- ◆ Monitor UPS running parameters.
- ◆ Timing off/on setting.

RS-232 communication data format

Baud rate ----- 9600bps

Byte length ----- 8bit

End bit ----- 1bit

Parity check -----none



CAUTION!

USB, RS232 and RS485 interface cannot be used at the same time, you can only use one of them at one time.

Appendix 5 RS485 communication port definition

Definition of port:

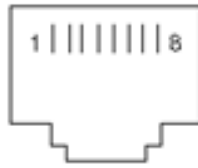

Connection between the Device' s RS485 port and UPS RS485 port.

device(RJ45)	UPS(RJ45)	Description
Pin 1/5	Pin 1/5	485+ "A "
Pin 2/4	Pin 2/4	485 - "B"
Pin 7	Pin 7	12V
Pin 8	Pin 8	GND

Available function of RS485

- ◆ Monitor UPS power status.
- ◆ Monitor UPS alarm info.
- ◆ Monitor UPS running parameters.
- ◆ Timing off/on setting.

Communication data format

Baud rate ----- 9600bps

Byte length ----- 8bit

End bit ----- 1bit

Parity check -----none



CAUTION!

USB, RS232 and RS485 interface cannot be used at the same time, you can only use one of them at one time.

RS485 port pin7 is 12Vdc!

Appendix 6 EPO instruction

EPO is emergency power off of UPS. This function can be used to turn off the load and UPS thermal protection. For example, when the indoor temperature is too high. When EPO is activated, the UPS immediately turns off all outputs and power converter, and the UPS remains in the fault alarm state.

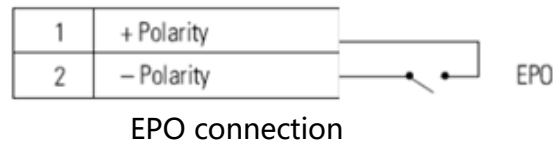

EPO function test:

- (1) Confirm that the machine is turned off and disconnected from the power grid;
- (2) The two pins of the EPO terminal are connected to a normally closed passive switch (e.g.: the connection terminal of the green female pin);
- (3) Connect to UPS and restart;
- (4) Turn on the EPO external switch. Test whether the UPS is turned off (e.g.: unplug the terminal);
- (5) UPS turns off when the switch is turned on, indicating that the EPO setting is valid;
- (6) To resume normal operation, close the external switch and restart the UPS.

Note: Please make sure that the EPO function is normal before using the UPS with critical equipment load to avoid unexpected power failure of the load.

