



User Manual

RM33E 10-50kVA

Solutions behind the power

All rights reserved.

The information in this document is subject to change without notice.

Publish statement

Thank you for purchasing this series UPS.

This series UPS is an intelligent, single phase in single phase out, high frequency online UPS designed by our R&D team who is with years of designing experiences on UPS. With excellent electrical performance, perfect intelligent monitoring and network functions, smart appearance, complying with EMC and safety standards, The UPS meets the world' s advanced level.

Read this manual carefully before installation

This manual provides technical support to the operator of the equipment.

3:3



Contents

1 · Safety	2
1.1 Safety notes	2
1.2 Symbols used in this guide	2
2 · Main Features	3
2.1 Summarization.....	3
2.2 Functions and Features.....	3
3 · Installation	4
3.1 Sub Rack UPS.....	4
3.2 Tower UPS.....	5
3.3 Cabinet Outlook.....	7
3.3 LCD control panel	9
3.4 Installation notes.....	9
3.5 External Protective Devices	10
3.6 Power Cables.....	11
3.7 Power cable connect	13
3.8 Battery connection.....	15
3.9 UPS parallel Installation	16
3.10 LBS installation	17
3.11 Computer access	19
4 · Operation	21
4.1 Operation Modes.....	21
4.2 Turn on/off UPS	24
4.3 The LCD Display.....	29
4.4 Display Messages/Troubleshooting.....	37
4.5 Options	39
Appendix 1 Specifications.....	41
Appendix 2 Problems and Solution.....	43
Appendix 3 USB communication port definition	44
Appendix 4 RS232 communication port definition.....	45
Appendix 5 RS485 communication port definition.....	46
Appendix 6 Dry contact port definition.....	47
Appendix 7 Backfeed protection port definition.....	48
Appendix 8 Optional port definition	48
Appendix 9 REPO instruction	49
Appendix 10 Sub rack UPS dimension	50
Appendix 11 Tower UPS dimension	51

1 · Safety

Important safety instructions - Save these instructions

There exists dangerous voltage and high temperature inside the UPS. During the installation, operation and maintenance, please abide the local safety instructions and relative laws, otherwise it will result in personnel injury or equipment damage. Safety instructions in this manual act as a supplementary for the local safety instructions. Our company will not assume the liability that caused by disobeying safety instructions.

1.1 Safety notes

1. Even no connection with utility power, 220/230/240VAC voltage may still exist at UPS terminal!
2. For the sake of human being safety, please well earth the UPS before starting it.
3. Don't open or damage battery, for the liquid spilled from the battery is strongly poisonous and do harmful to body!
4. Please avoid short circuit between anode and cathode of battery, otherwise, it will cause spark or fire!
5. Don't disassemble the UPS cover, or there may be an electric shock!
6. Check if there exists high voltage before touching the battery
- 7 · Working environment and storage way will affect the lifetime and reliability of the UPS. Avoid the UPS from working under following environment for long time
 - ◆ Area where the humidity and temperature is out of the specified range(temperature 0 to 40℃ , relative humidity 5%-95%)
 - ◆ Direct sunlight or location nearby heat
 - ◆ Vibration Area with possibility to get the UPS crashed.
 - ◆ Area with erosive gas, flammable gas, excessive dust, etc
- 8 · Keep ventilations in good conditions otherwise the components inside the UPS will be over-heated which may affect the life of the UPS.

1.2 Symbols used in this guide



WARNING!

Risk of electric shock



CAUTION!

Read this information to avoid equipment damage

2 · Main Features

2.1 Summarization

This series UPS is a kind of three-in-three-out high frequency online UPS.

The UPS can solve most of the power supply problems, such as blackout, over-voltage, under-voltage, voltage sudden drop, oscillating of decreasing extent, high voltage pulse, voltage fluctuation, surge, inrush current, harmonic distortion (THD), noise interference, frequency fluctuation, etc..

This UPS can be applied to different applications from computer device, automatic equipment, communication system to industry equipment.

2.2 Functions and Features

◆ Integrated solution for data center

UPS can be integrated with battery cabinet, PDU external maintenance bypass, offering excellent choice for data center.

◆ 3Phase In/3Phase Out UPS

It is 3Phase In/3Phase Out high-density UPS system, of which input current is kept in balance.

No unbalance problem might occur.

◆ Digital Control

This series UPS is controlled by Digital Signal Processor (DSP); enhance, it increases reliability, performance, self-protection, and self-diagnostics and so on.

◆ Battery Configurable

From 30 blocks to 50 blocks, the battery voltage of this series UPS can be configured at 30 blocks, 32 blocks, 34 blocks, 36 blocks, 38 blocks, 40 blocks, 42 blocks, 44 blocks, 46 blocks, 48 blocks or 50 blocks according to your convenience.

◆ Charging Current is configurable

Via setting tool, the user may set the capacity of the batteries as well as reasonable charging current as well as maximum charging current. Constant voltage mode, constant current mode or floating mode can be switched automatically and smoothly.

◆ Intelligent Charging Method

The series UPS adopts advanced three-stage charging method—

1st stage: high current constant current charging

to guarantee to charge back to 90%;

2nd-stage: Constant Voltage

In order to vitalize battery and make sure batteries are fully charged 3rd stage: floating mode.

With this 3-stage charging method, it extends the life of the batteries and guarantees fast charging.

◆ LCD Display

With LCD plus LED displays, the user may easily get UPS status and its operational parameters, such as input/output voltage, frequency & load%, battery % and ambient temperature, etc...

◆ Intelligent Monitoring Function

Via optional SNMP Card, you may remotely control and monitor the UPS.

◆ EPO Function

The series UPS may be completely shut off when the EPO is pressed. REPO function (Remote EPO) is also available in this series UPS.

3 · Installation

3.1 Sub Rack UPS

3.1.1 Appearance of UPS

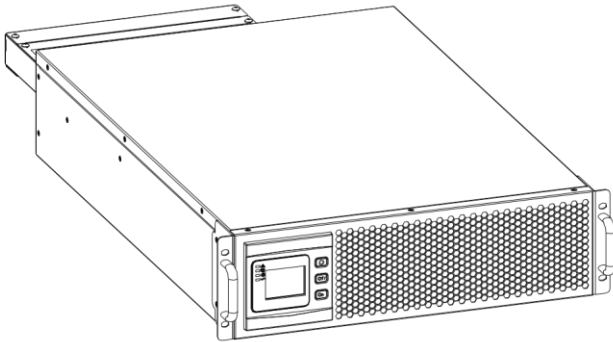

10/15/20/25/30kVA

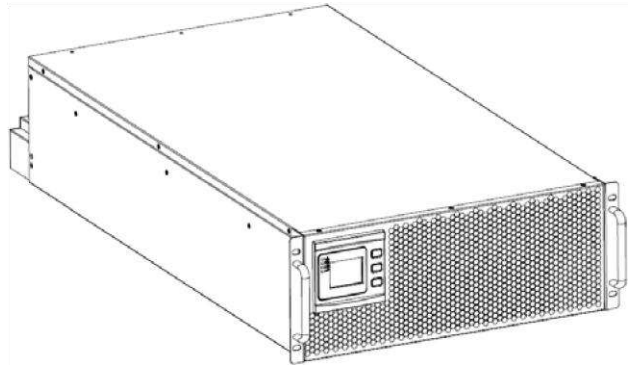

40/50kVA

3.1.2 Installation

Adjust the length of the rails according to the following figure according to the distance of the cabinet and fix the rails.

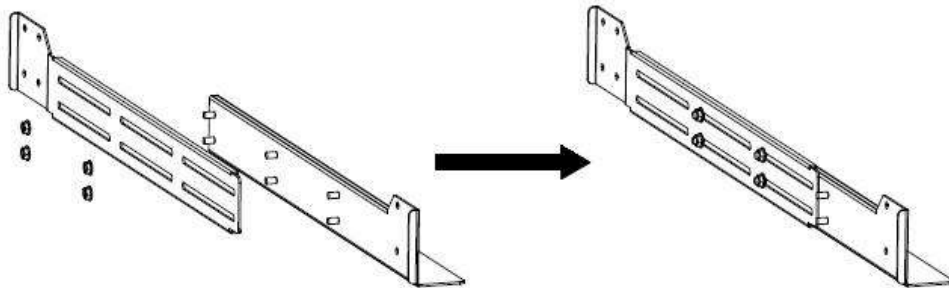

Fix the rails to the cabinet.

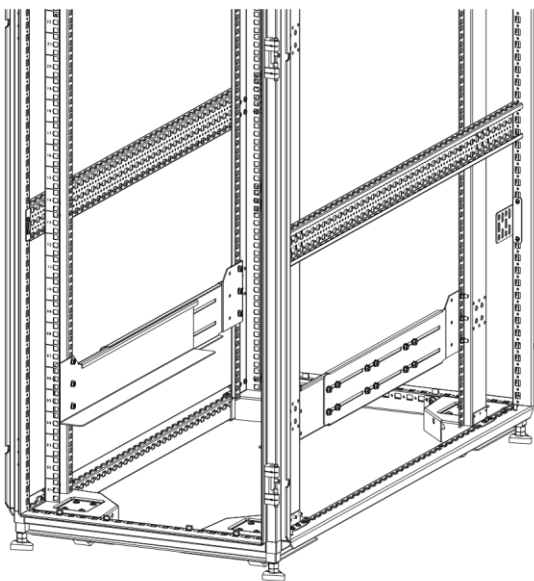

10/15/20/25/30kVA

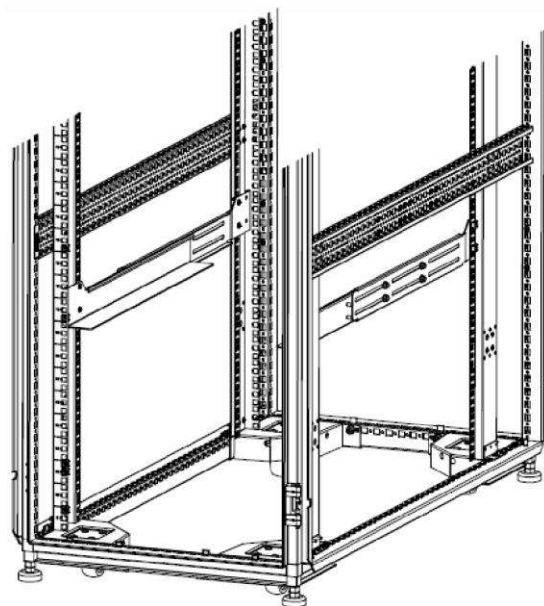

40/50kVA

After installing the rails, install the floating screw according to the front panel of the UPS, then insert the UPS into the cabinet on the rails and fix the screws.

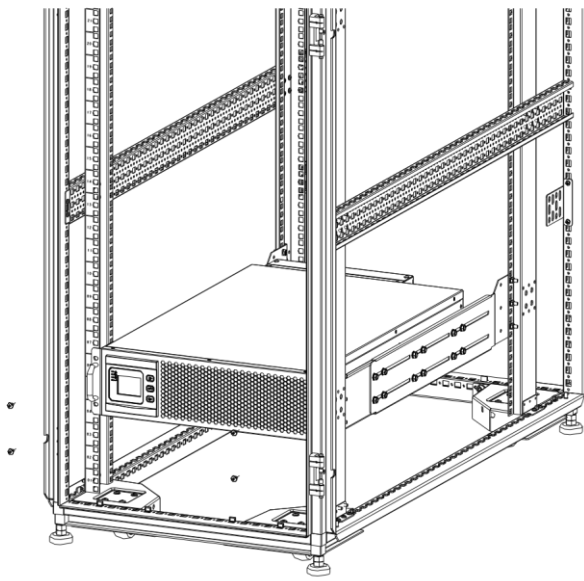

10/15/20/25/30kVA

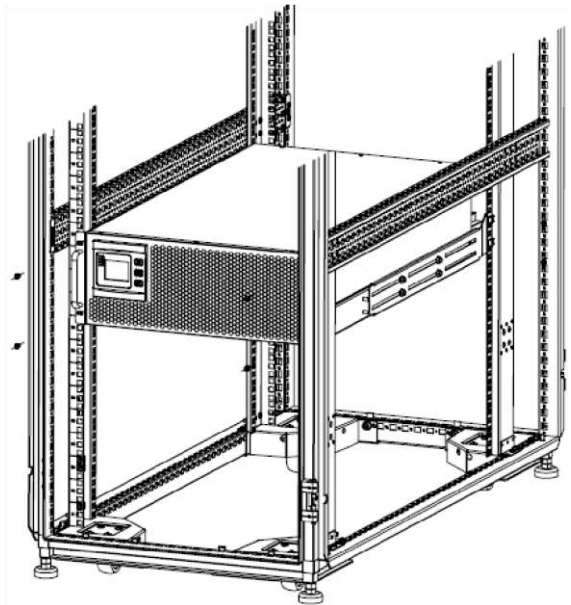

40/50kVA

3.2 Tower UPS

3.2.1 Appearance of UPS

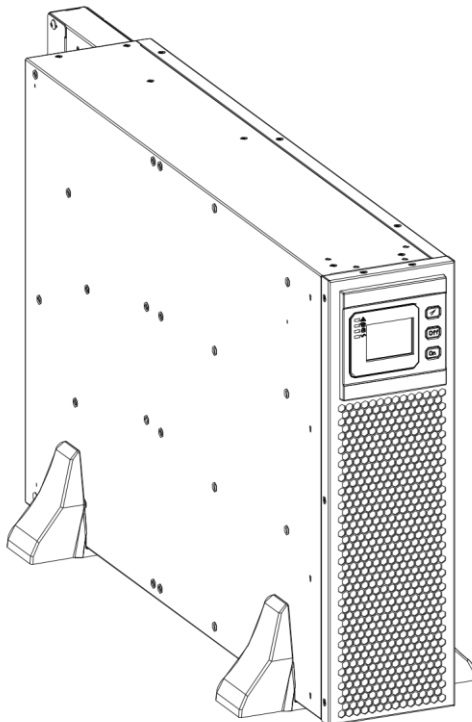

10/15/20/25/30kVA

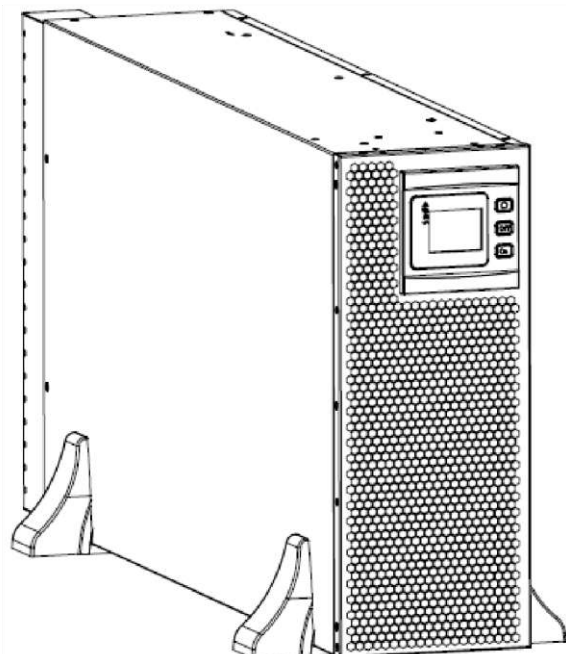

40/50kVA

3.2.2 Installation

Remove the fix handles of the UPS

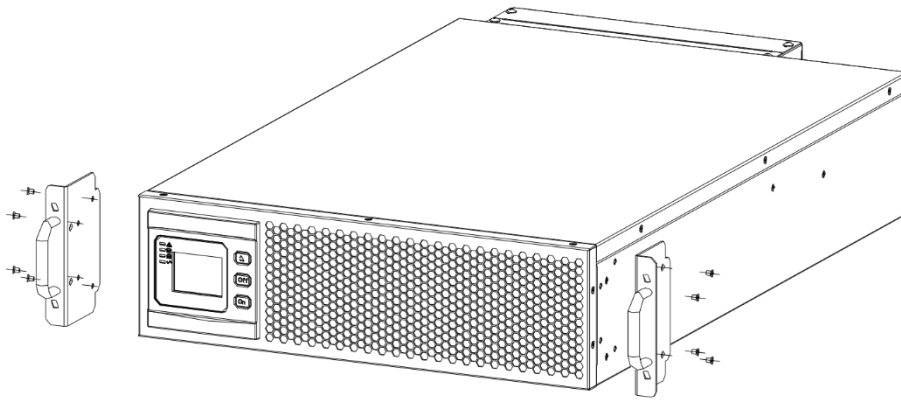

10/15/20/25/30kVA

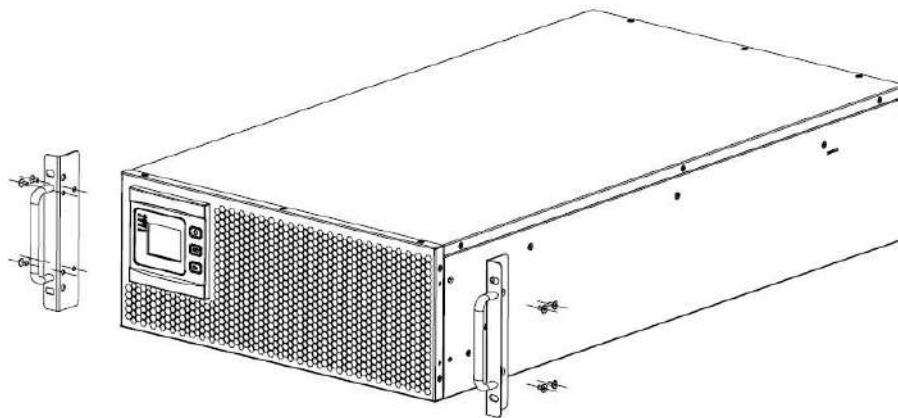

40/50kVA

Assemble the bracket, according to the size of the UPS, and then the UPS can be directly placed on the bracket.

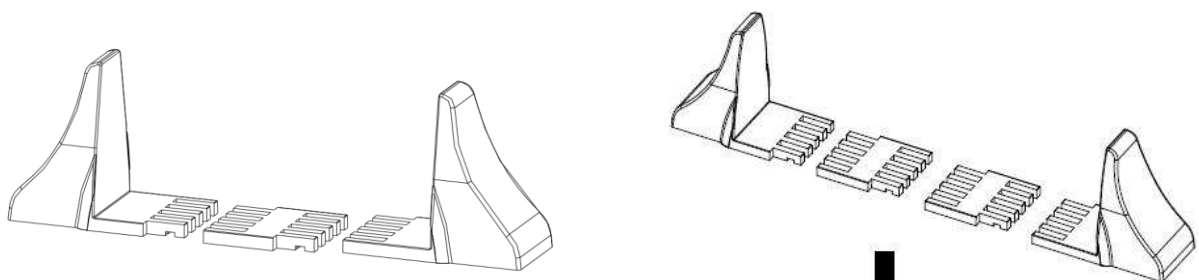

10/15/20/25/30kVA

40/50kVA

3.3 Cabinet Outlook

10/15/20/25/30kVA:

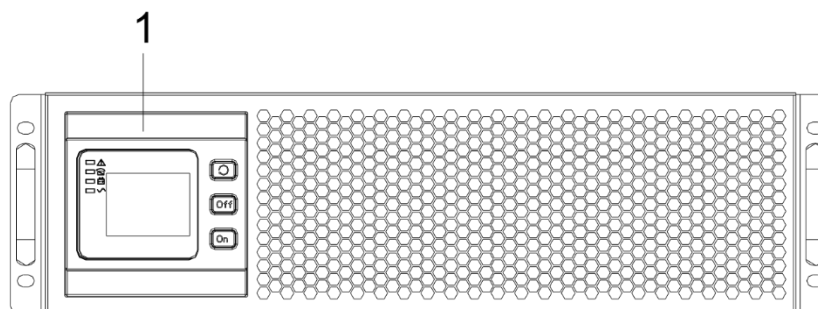

Front View

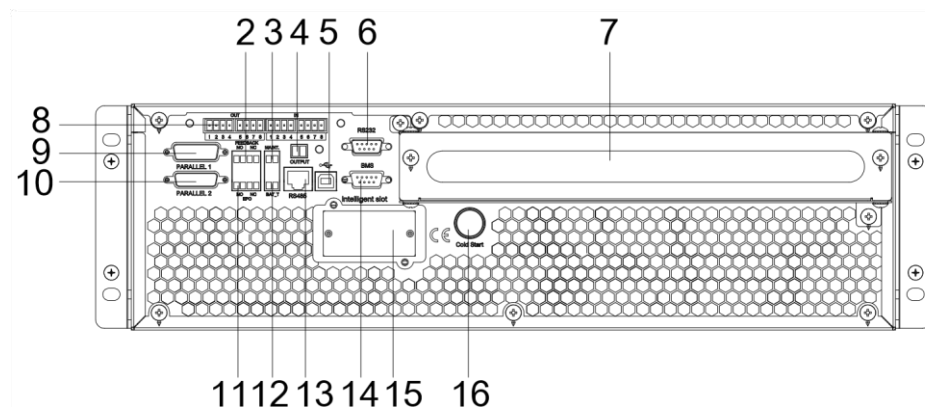

Rear View

(1) LCD panel	(2) Backfeed protection port
(3) MAINTAIN-AUXSWS port	(4) Output breaker aux contactor
(5) USB port	(6) RS232 port
(7) Terminal block for Input, output & battery	(8) Dry contact port
(9) Parallel port 1	(10) Parallel port 2
(11) EPO port	(12) Temperature sensor port (for NTC)
(13) RS485 port	(14) BMS port (optional)
(15) Intelligent Slot (SNMP card)	(16) Cold-start button

40/50kVA:

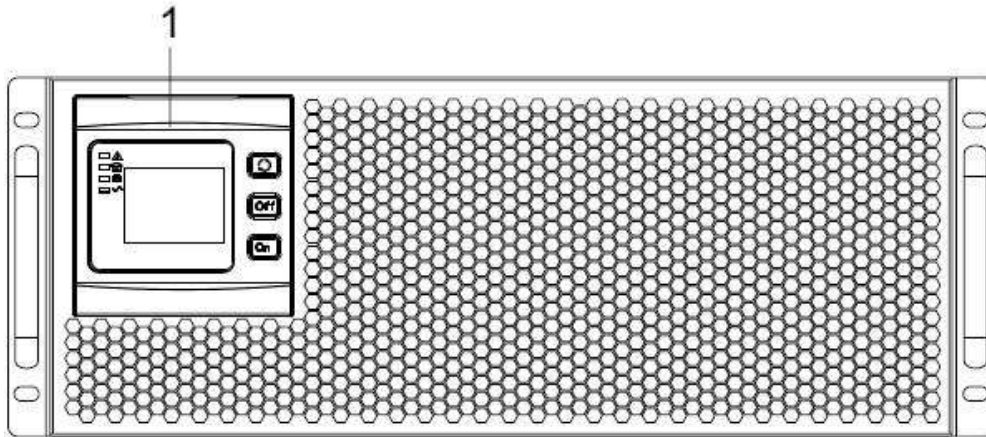

Front View

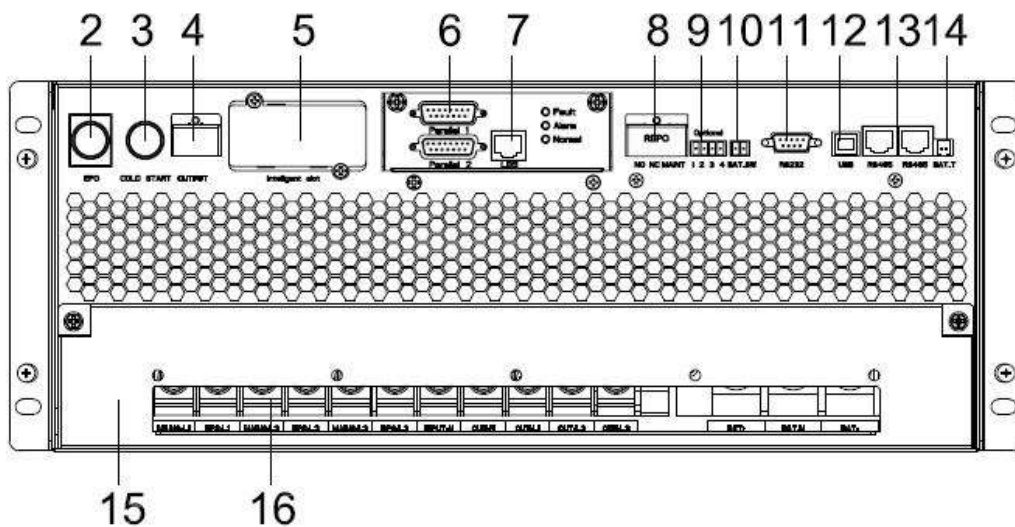

Rear View

(1) LCD panel	(2) EPO port
(3) Cold-start button	(4) Output breaker aux contactor
(5) Intelligent Slot (SNMP card/ Relay card)	(6) Parallel port 1&2
(7) LBS port	(8) MAINTAIN-AUXSWS port and REPO port
(9) Optional port (Port for backfeed protection, or for battery breaker driver to prevent battery over-drain after UPS shuts down)	(10) BAT_SW : detect battery switch status
(11) RS232	(12) USB port
(13) RS485 port	(14) Temperature sensor port (for NTC)
(15) Terminal cover	(16) Terminal

3.3 LCD control panel

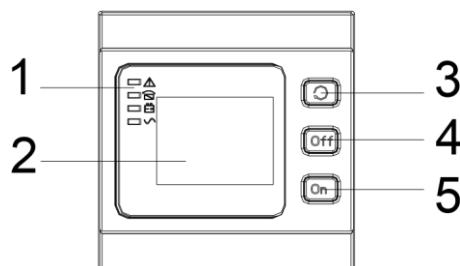

LCD control panel introduction

- (1) LED (from top to bottom: “alarm”, “bypass”, “battery”, “inverter”) (2) LCD display
 (3) scroll button (4) Off button (5) On button

3.4 Installation notes

Note: Consider for the convenience of operation and maintenance, the space in front and back of the cabinet should be left at least 100cm and 80cm respectively when installing the cabinet.

◆ Please place the UPS in a clean, stable environment, avoid the vibration, dust, humidity, flammable gas and liquid, corrosive. To avoid from high room temperature, a system of room extractor fans is recommended to be installed. Optional air filters are available if the UPS operates in a dusty environment.

◆ The environment temperature around UPS should keep in a range of 0°C~40°C. If the environment temperature exceeds 40°C, the rated load capacity should be reduced by 12% per 5°C. The max temperature can't be higher than 50°C.

◆ If the UPS is dismantled under low temperature, it might be in a condensing condition. The UPS can't be installed unless the internal and external of the equipment is fully dry. Otherwise, there will be in danger of electric shock.

◆ Batteries should be mounted in an environment where the temperature is within the required specs. Temperature is a major factor in determining battery life and capacity. In a normal installation, the battery temperature is maintained between 15°C and 25°C. Keep batteries away from heat sources or main air ventilation area, etc.



WARNING!

Typical battery performance data are quoted for an operating temperature between 20°C and 25°C. Operating it above this range will reduce the battery life while operation below this range will reduce the battery capacity.

◆ Should the equipment not be installed immediately it must be stored in a room so as to protect it against excessive humidity and or heat sources.



CAUTION!

An unused battery must be recharged every 6months Temporarily connecting the UPS to a suitable AC supply mains and activating it for the time required for recharging the batteries.

◆ The highest altitude that UPS may work normally with full load is 1500 meters. The load capacity should be reduced when this UPS is installed in place whose altitude is higher than 1500 meters, shown as the following table:

(Load coefficient equals max load in high altitude place divided by nominal power of the UPS)

Altitude (m)	1500	2000	2500	3000	3500	4000	4500	5000
Load coefficient	100%	95%	90%	85%	80%	75%	70%	65%

◆ The UPS cooling is depending on fan, so it should be kept in good air ventilation area. There are many ventilation holes on the front and rear, so they should not be blocked by any exotic obstacles.

3.5 External Protective Devices

For safety reasons, it is necessary to install, external circuit breaker at the input A.C. supply and the battery. This chapter provides guidelines for qualified installers that must have the knowledge of local wiring practices for the equipment to be installed.

◆ External Battery

The UPS and its associated batteries are protected against the effect of over-current through a DC compatible thermo-magnetic circuit-breaker (or a set of fuses) located close to the battery.

◆ UPS Output

Any external distribution board used for load distribution shall be fitted with protective devices that may avoid the risk of UPS overloaded.

◆ Over-current

Protection device shall be installed at the distribution panel of the incoming main supply. It may identify the power cables current capacity as well as the overload capacity of the system.

3.6 Power Cables

◆ The cable design shall comply with the voltages and currents provided in this section, Kindly follow local wiring practices and take into consideration the environmental conditions (temperature and physical support media) .



WARNING!

Upon starting. Please ensure that you are aware of the location and operation of the external isolators which are connected to the UPS input/bypass supply of the mains distribution panel. Check to see if these supplies are electrically isolated. And post and necessary warning signs to prevent any inadvertent operation.

3.6.1 Recommended cross-sectional areas for power cables

UPS cabinet	Cable Dimension			
	AC Input (mm ²)	AC Output (mm ²)	DC Input (mm ²)	Grounding (mm ²)
10kVA	4	4	6	4
15kVA	6	6	8	6
20kVA	10	10	16	10
25kVA	16	16	25	16
30kVA	16	16	25	16
40kVA	25	16	35	16
50kVA	25	25	50	25

- ◆ When selecting, connecting, and routing power cables, follow local safety regulations and rules.
- ◆ If external conditions such as cable layout or ambient temperatures change, perform verification in accordance with the IEC-60364-5-52 or local regulations.
- ◆ If the rated voltage is 400 V, multiply the currents by 0.95. If the rated voltage is 415 V, multiply the currents by 0.92.
- ◆ If primary loads are non-linear loads, increase the cross-sectional areas of neutral wires 1.5– 1.7 times.
- ◆ The nominal battery discharge current refers to the current of forty 12 V batteries at 480V in standard configuration.
- ◆ The maximum battery discharge current refers to the current when forty 12 V batteries in standard configuration, that is, two hundred and forty 2 V battery cells (1.67 V/cell), stop discharging.
- ◆ The battery cable specifications are selected based on 40 batteries by default and compatible with application scenarios with 30–50 batteries.
- ◆ When the mains input and bypass input share a power source, configure both types of input power cables as mains input power cables. The cables listed in Table are used only when the following requirements are met:
 - Routing mode: Routing the cables over the cable ladder or bracket in a single layer (IEC60364-5-52 middle E).
 - The ambient temperature is 30°C.
 - The AC voltage loss is less than 3%, and the DC voltage loss is less than 1%.
 - 90°C copper flexible cable.
 - The length of the AC power cables of a UPS is no longer than 30 m and DC power cables no longer than 50 m.

3.6.2 Power cable connector requirements

Model	Connector	Connection Mode	Bolt Type	Bolt Hole Diameter	Torque
10/15/20/25/30kVA	Mains input connector	Crimped OT terminals	L-M4/N-M6	4.5/7mm	2/7N•m
	Bypass input connector	Crimped OT terminals	L-M4/N-M6	4.5/7mm	2/7N•m
	Battery input connector	Crimped OT terminals	M6	7mm	7N•m
	Output connector	Crimped OT terminals	L-M4/N-M6	4.5/7mm	2/7N•m
	Grounding connector	Crimped OT terminals	M6	7mm	7N•m
40/50kVA	Mains input connector	Crimped OT terminals	M6	7mm	7N•m
	Bypass input connector	Crimped OT terminals	M6	7mm	7N•m
	Battery input connector	Crimped OT terminals	M8	9mm	15N•m
	Output connector	Crimped OT terminals	M6	7mm	7N•m
	Grounding connector	Crimped OT terminals	M6	7mm	7N•m

3.6.3 Recommended input front-end and output back-end circuit breakers

Model	Mains input circuit breaker	Bypass input circuit breaker	Maintenance circuit breaker	Output circuit breaker	Battery circuit breaker
10kVA	20A 3P	20A 3P	20A 4P	20A 3P	32A 3P
15kVA	32A 3P	32A 3P	32A 4P	32A 3P	50A 3P
20kVA	40A 3P	40A 3P	40A 4P	50A 3P	63A 3P
25kVA	50A 3P	50A 3P	50A 4P	50A 3P	80A 3P
30kVA	63A 3P	63A 3P	63A 4P	63A 3P	100A 3P
40kVA	80A 3P	80A 3P	80A 4P	80A 3P	125A 3P
50kVA	100A 3P	100A 3P	100A 4P	100A 3P	160A 3P



CAUTION!

Protective earth cable: Connect each cabinet to the main ground system. For Grounding connection, follow the shortest route possible.



WARNING!

Failure to follow adequate earthing procedures may result in electromagnetic interference or in hazards involving electric shock and fire

3.7 Power cable connect

Once the equipment has been finally positioned and secured, connect the power cables as described in the following procedure.

Verify the UPS is totally isolated from its external power source and also all power isolators of the PDU are open. Check to see if they are electrically isolated, and post any necessary warning signs to prevent their inadvertent operation.

Open the UPS rear panel; Remove the cover of terminals for wiring easily.

3.7.1 Common input connection

10/15/20/25/30kVA

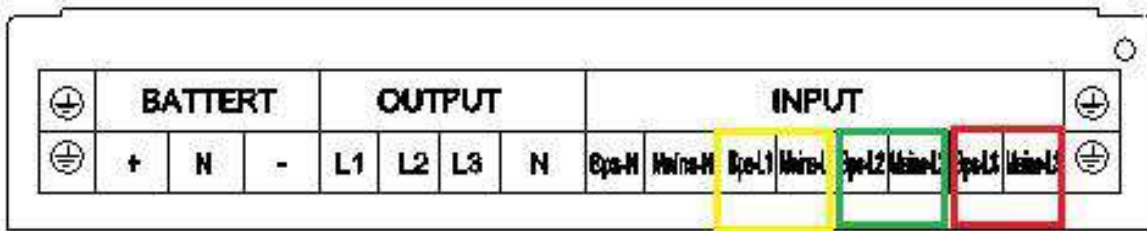

40/50kVA

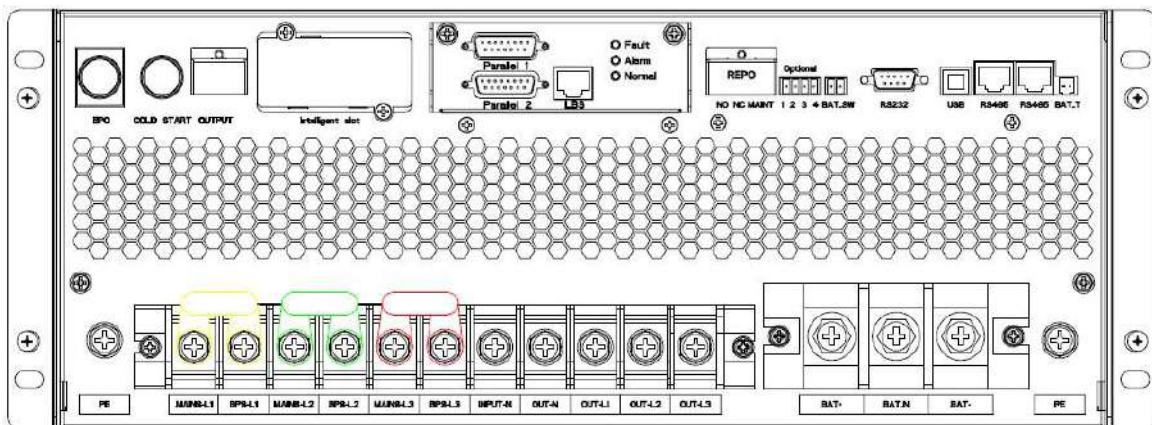

INPUT Primary input Line	OUTPUT
	Vout-L1: Output Phase L1
Vin-L1: Primary input Phase L1	Vout -L2: Output Phase L2
Vin-L2: Primary input Phase L2	Vout -L3: Output Phase L3
Vin-L3: Primary input Phase L3	Vout -N: Output Neutral
Vin-N: Input Neutral for primary and secondary input	PE: Grounding
	BAT+: Positive terminal of the batteries string
	BATN: Neutral terminal of the batteries string
	BAT-: Negative terminal of the batteries string

3.7.2 Dual input connection 30kVA

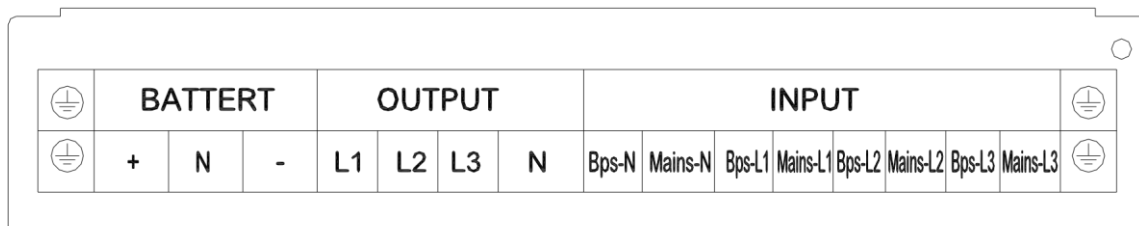

40/50kVA

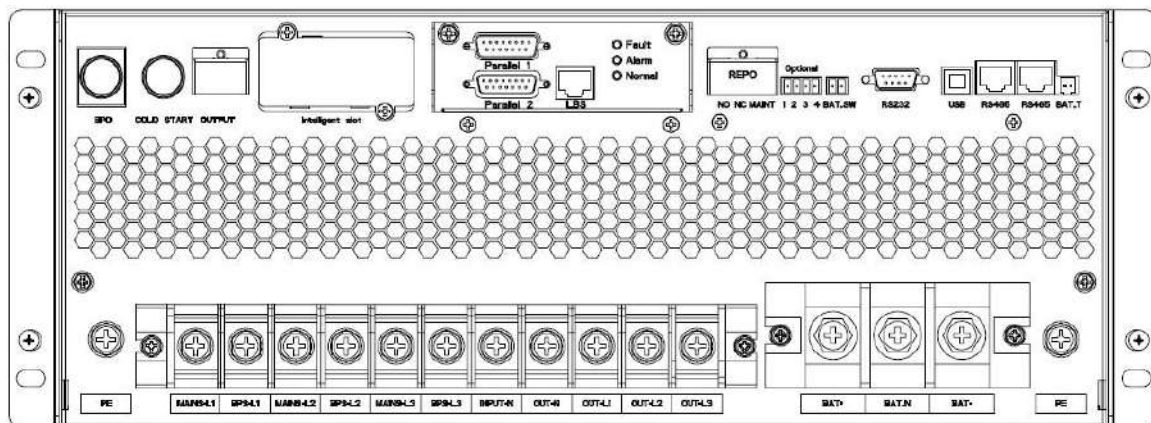

Mains Primary input Line	Output
Bypass Secondary/Bypass input line (optional)	Vout-L1: Output Phase L1
Vin-L1: Primary input Phase L1	Vout-L2: Output Phase L2
Vin-L2: Primary input Phase L2	Vout-L3: Output Phase L3
Vin-L3: Primary input Phase L3	Vout-N: Output Neutral
Vin-N: Input Neutral for primary and secondary input	PE: Grounding
BPS-L1: Secondary input Phase L1	BAT+: Positive terminal of the batteries string
BPS-L2: Secondary input Phase L2	BATN: Neutral terminal of the batteries string
BPS-L3: Secondary input Phase L3	BAT-: Negative terminal of the batteries string

Warning!



In the case of “Dual input” operation, make sure the copper wire between each input lines have been removed. The AC input and the AC bypass supplies must be referenced to the same neutral point.

Choose appropriate power cable. (Refer to the table above) and pay attention to the diameter of the connection terminal of the cable that should be greater than or equal to that of the connection poles;

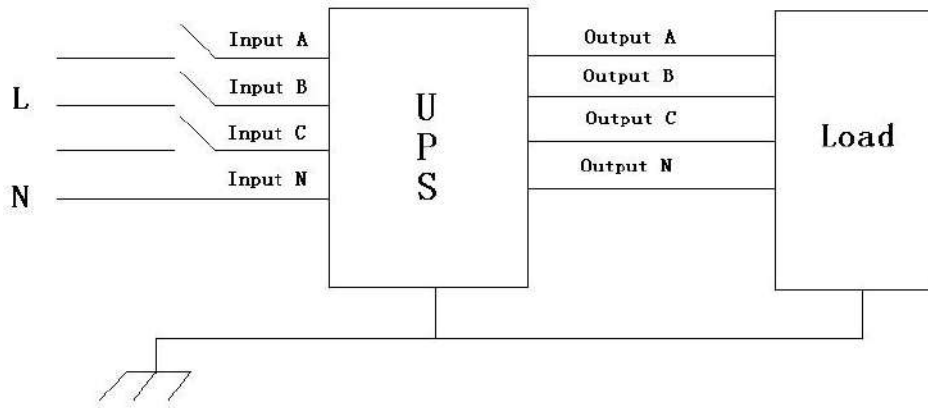

WARNING!



If the load equipment is not ready to accept power on the arrival of the commissioning engineer then ensure that the system output cables are safely isolated at their ends

Connect the safety earth and any necessary bonding earth cables to the copper earth screw located on the floor of the equipment below the power connections. All cabinets in the UPS must be grounded properly.



CAUTION!

The earthing and neutral bonding arrangement must be in accordance with local and national codes of practice.

3.8 Battery connection

The UPS adopts positive and negative double battery framework, total 30(optional 32/34/36/38/40/42/44/46/48/50) in series. A neutral cable is retrieved from the joint between the cathode of the 15th (16th/17th/18th/19th/20th/21th/22th/23th/24th/25th) and the anode of the 16th (17th/18th/19th/20th/21th/22th/23th/24th/25th/26th) of the batteries. Then the neutral cable, the battery Positive and the battery negative are connected with the UPS respectively. The battery sets between the Battery anode and the neutral are called positive batteries and that between neutral and cathode are called negative ones. The user can choose the capacity and the numbers of the batteries according to their desire.

External battery connections for long-run units.

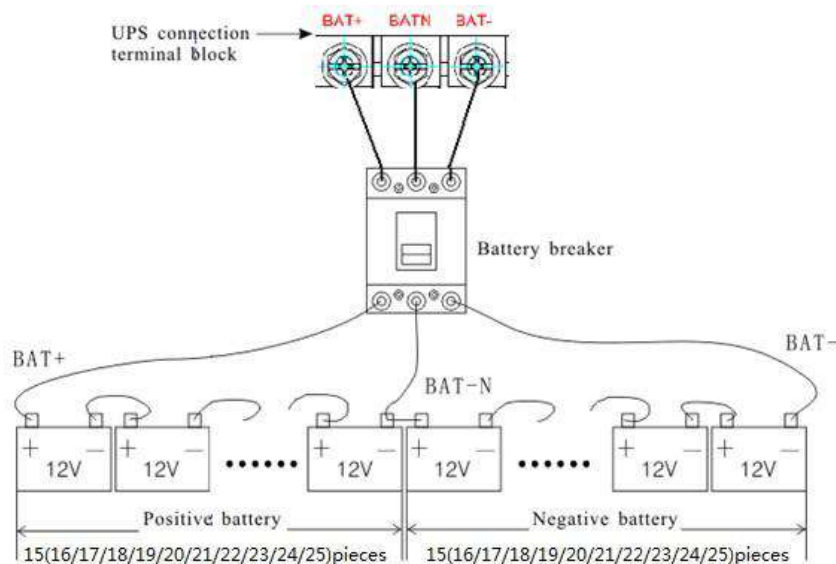

Note :

The BAT+ of the UPS connect poles is connected to the anode of the positive battery, the BAT-N is connected to the cathode of the positive battery and the anode of the negative battery, the BAT- is connected to the cathode of the negative battery.

factory setting of the long-run unit is battery quantity---30pcs, battery capacity---12V65AH (charger current 6.5A). When connecting 32/34/36/38/40/42/44/46/48/50 batteries, please re-set desired battery quantity and its capacity after UPS starts at AC mode. Charger current could be adjusted automatically according to battery capacity selected. All related settings can be done through LCD panel or monitoring software



CAUTION!

Ensure correct polarity battery string series connection. I.e. inter-tier and inter block connections are from (+) to (-) terminals. Don't mix batteries with different capacity or different brands, or even mix up new and old batteries, either.



WARNING!

Ensure correct polarity of string end connections to the Battery Circuit Breaker and from the Battery Circuit Breaker to the UPS terminals i.e. (+) to (+) / (-) to (-) but disconnect one or more battery cell links in each tier. Do not reconnect these links and do not close the battery circuit breaker unless authorized by the commissioning engineer.

3.9 UPS parallel Installation

The following sections introduce the installation procedures specified to the parallel system.

3.9.1 Cabinet installation

Connect all the UPS needed to be put into parallel system as below picture.

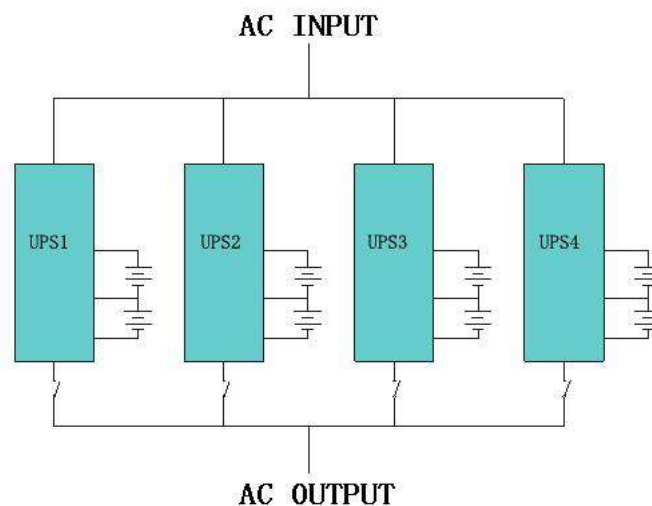

Make sure each UPS input breaker is in "off" position and there is no any output from each UPS connected. Battery groups can be connected separately or in parallel, which means the system itself provides both separate battery and common battery.



WARNING!

Make sure the N, A (L1), B (L2), C (L3) lines are correct, and grounding is well connected.

3.9.2 Parallel cable installation

Shielded and double insulated control cables available must be interconnected in a ring configuration between UPS units as shown below. The ring configuration ensures high reliability of the control.

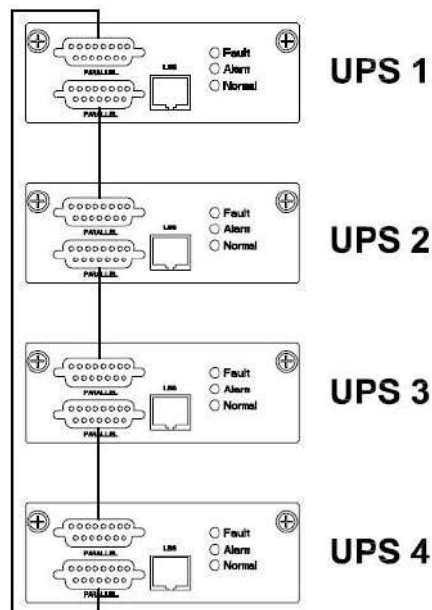

3.9.3 Requirement for the parallel system

A group of paralleled UPS behaves as one large UPS system but with the advantage of presenting higher reliability. In order to assure that all UPS are equally utilized and comply with relevant wiring rules, please follow the requirements below:

- 1) All UPS must be of the same rating and be connected to the same bypass source.
- 2) The outputs of all the UPS must be connected to a common output bus.
- 3) The length and specification of power cables including the bypass input cables and the UPS output cables should be the same. This facilitates load sharing when operating in bypass mode.

3.10 LBS installation

LBS system contains LCD set, communication cable and STS device.

3.10.1 LCD setting

Set every UPS of the systems to be LBS Master or LBS Slave. For instance if the UPS belongs to LBS master system, its LBS setting must be set to Master.

3.10.2 LBS cable installation

The two ports of one mesh wire should be plug into RJ45 interface of any one UPS of both master and slave system.

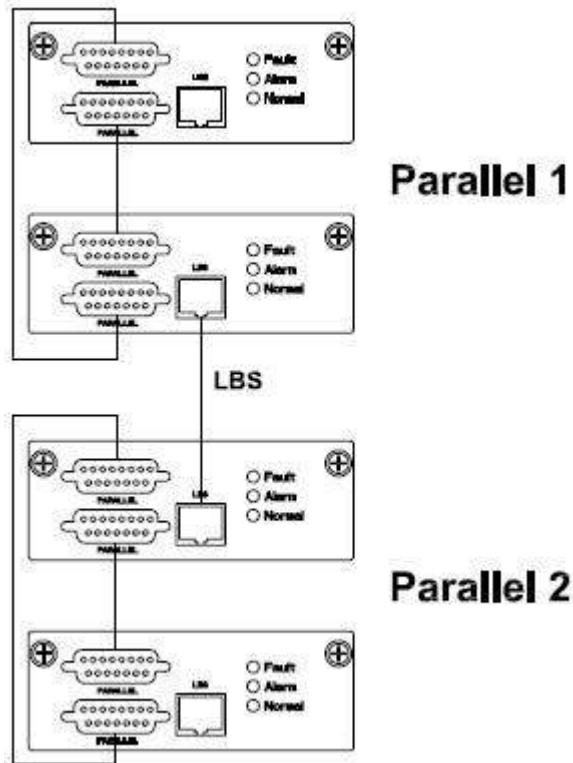

3.10.3 UPS installation

The whole systems is showed below.

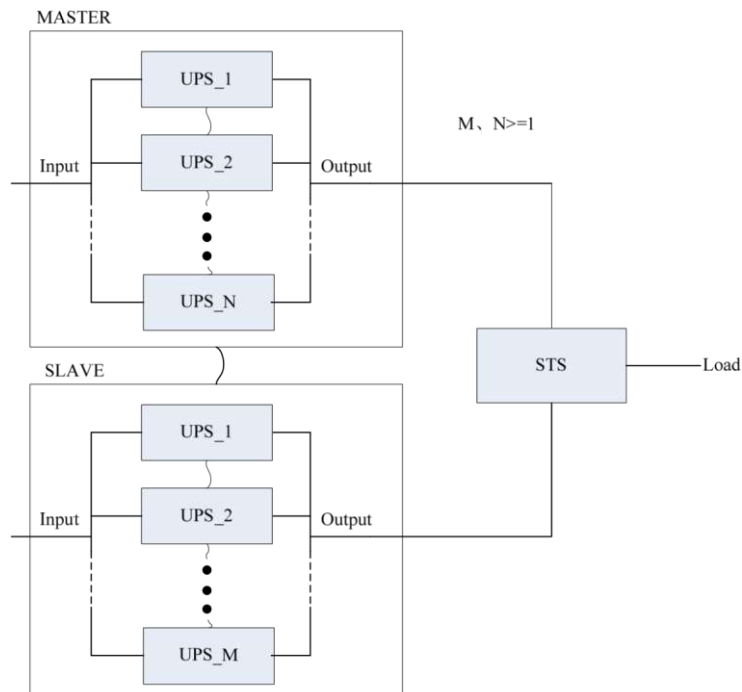

3.11 Computer access

- ◆ One end of a USB cable connect to the computer, the other end connect to the USB port on the UPS.
- ◆ Open the software Muser5000, click “system” button.



- ◆ A window of “Software Parameter Setting” comes out as below, COM choose according to the UPS , baud rate choose 9600, protocol choose “modbus”, then save this setting.



- ◆ On the main page of Muser5000, click the button of “Append”, then goes to a window of “Append equipment”. Password is YDC3350.

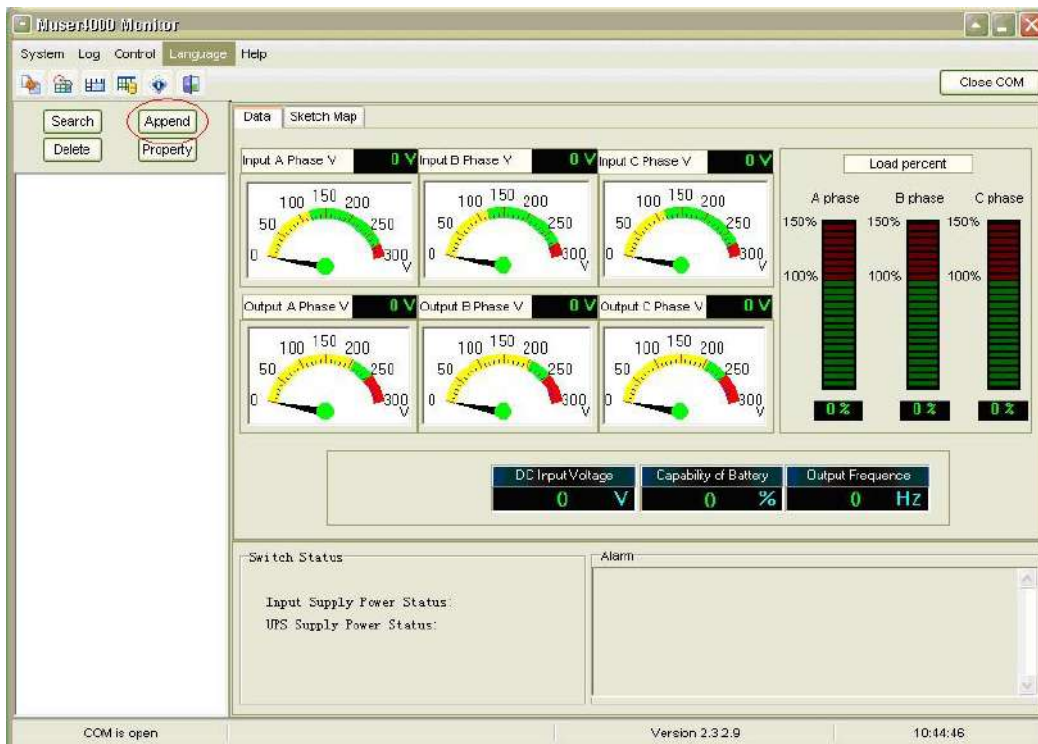

- ◆ Put the UPS name into “Equipment Name”, and UPS’ ID address into “Equipment address”.



- ◆ Click the button “Append”, then the connection between UPS & computer is accomplished.



CAUTION!

When the UPS worked on inverter. If you want to use PC to set the output voltage and frequency. Must shut down the inverter first

4 · Operation

4.1 Operation Modes

The UPS is a double-conversion on-line UPS that may operate in the following alternative modes :

◆ Normal mode

The rectifier/charger derives power from the AC Mains and supplies DC power to the inverter while floating and boosting charge the battery simultaneously. Then, the inverter converts the DC power to AC and supplies to the load.

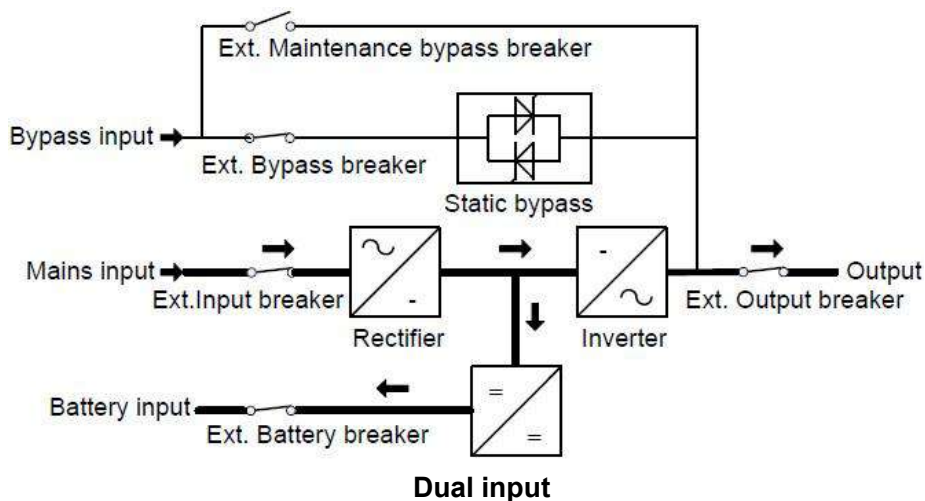
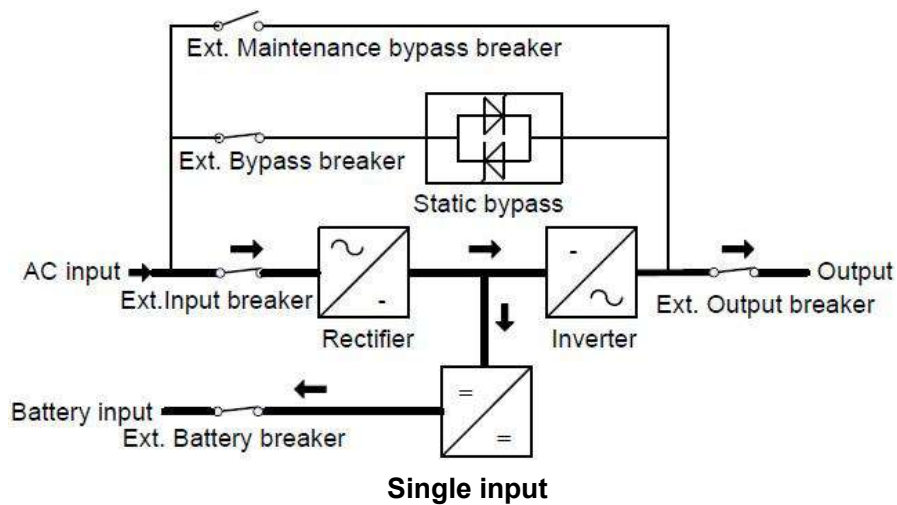

◆ Battery mode (Stored Energy Mode)

If the AC mains input power fails, the inverter, which obtains power from the battery, supplies the critical AC load. There is no power interruption to the critical load. The UPS will automatically return to Normal Mode when AC recovers.

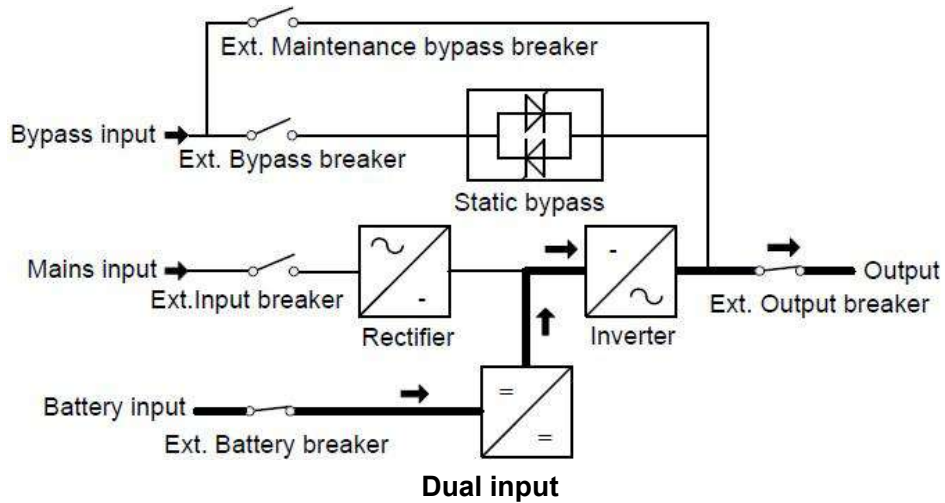
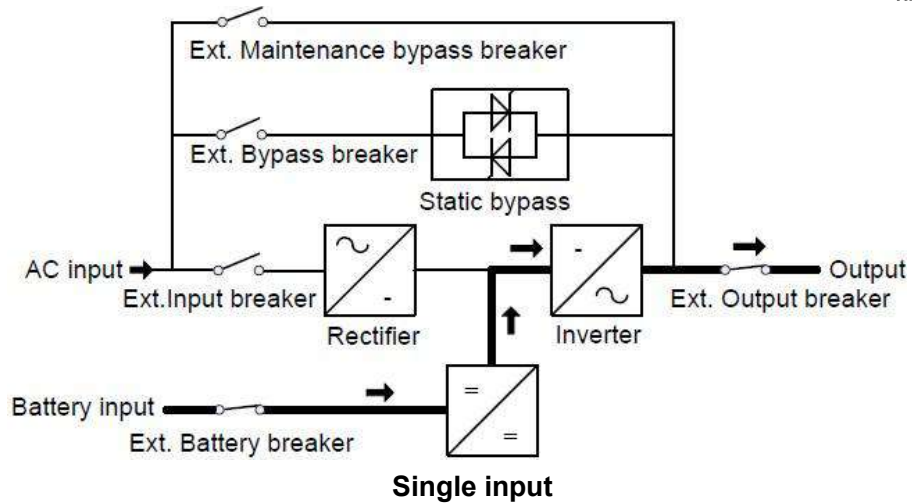

◆ **Bypass mode**

If the inverter is out of order, or if overload occurs, the static transfer switch will be activated to transfer the load from the inverter supply to bypass supply without interruption to the critical load. In the event that the inverter output is not synchronized with the bypass AC source, the static switch will perform a transfer of the load from the inverter to the bypass with power interruption to the critical AC load. This is to avoid paralleling of unsynchronized AC sources. This interruption is programmable but typically set to be less than an electrical cycle e.g. less than 15ms (50Hz) or less than 13.33ms (60Hz).

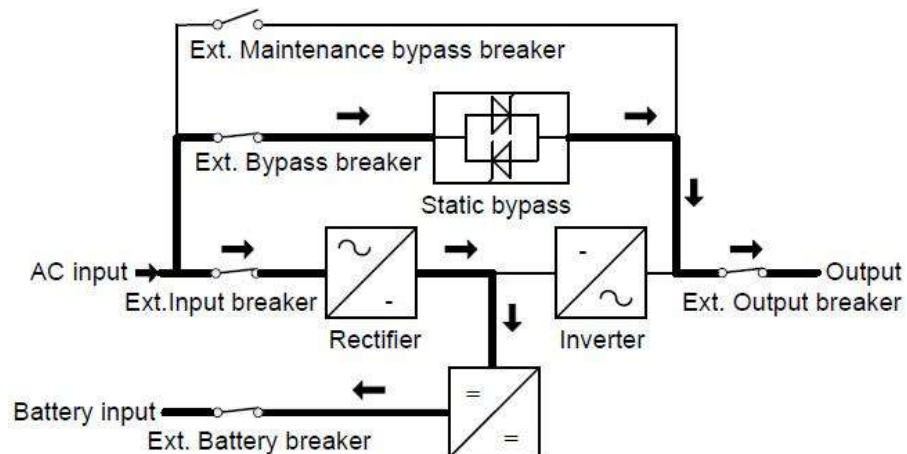

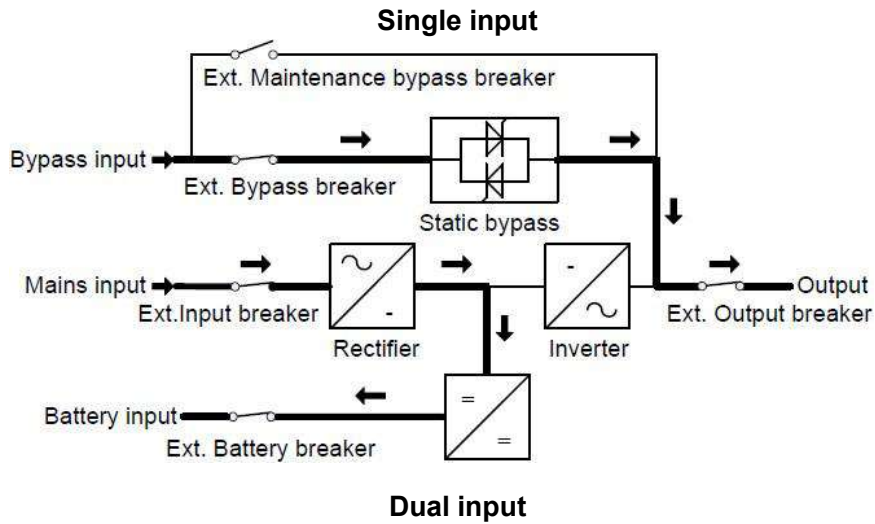

◆ **ECO Mode**

When the UPS is at AC Mode and the requirement to the load is not critical, the UPS can be set at ECO mode in order to increase the efficiency of the power supplied. At ECO mode, the UPS works at Line-interactive mode, so the UPS will transfer to bypass supply. When the AC is out of set window, the UPS will transfer from bypass to Inverter and supplies power from the battery, and then the LCD shows all related information on the screen.

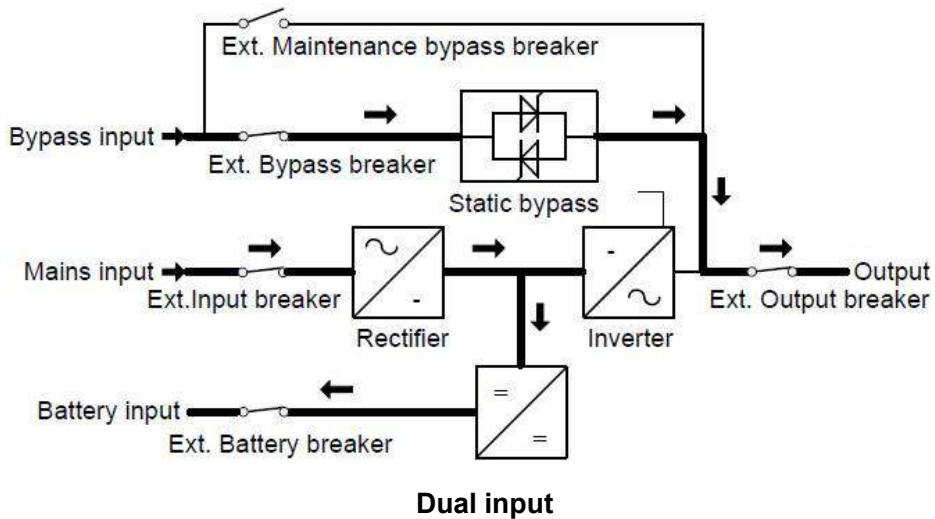
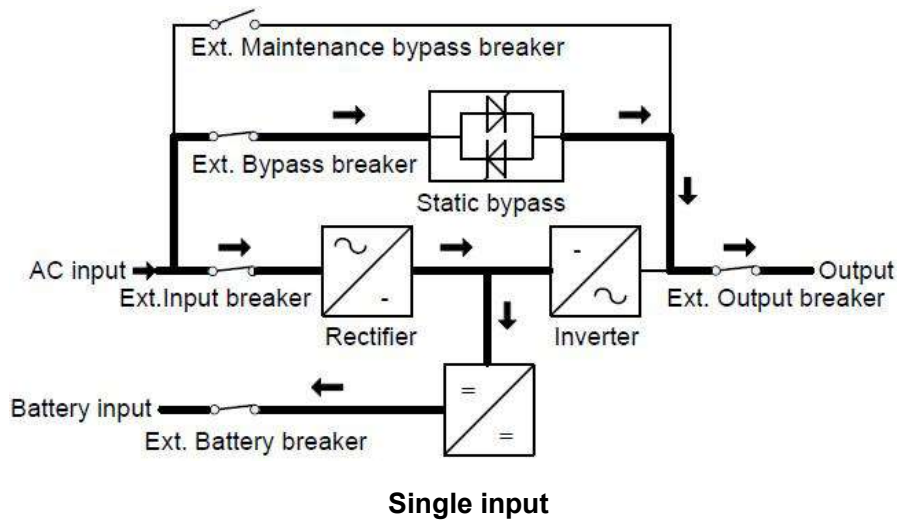

◆ Maintenance mode (Manual Bypass)

A manual bypass switch is available to ensure continuity of supply to the critical load when the UPS is out of order or in repair and this manual bypass switch bears for equivalent rated load.

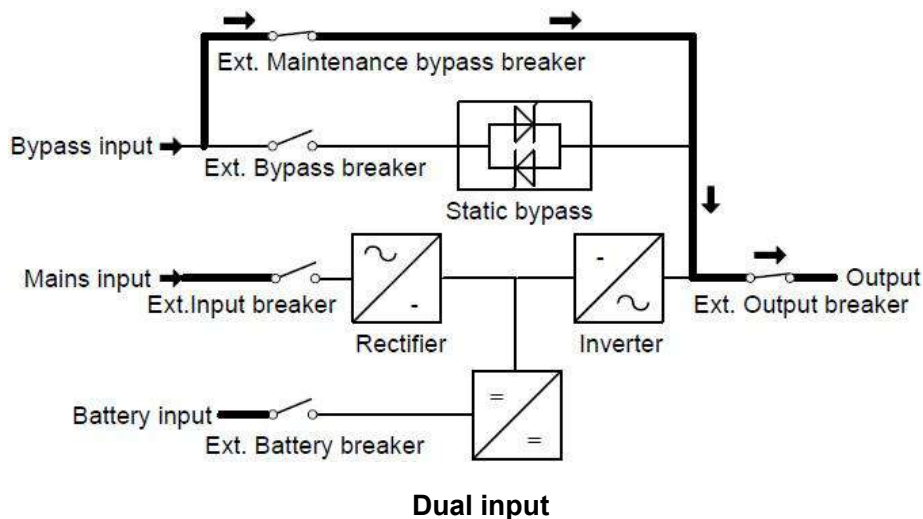
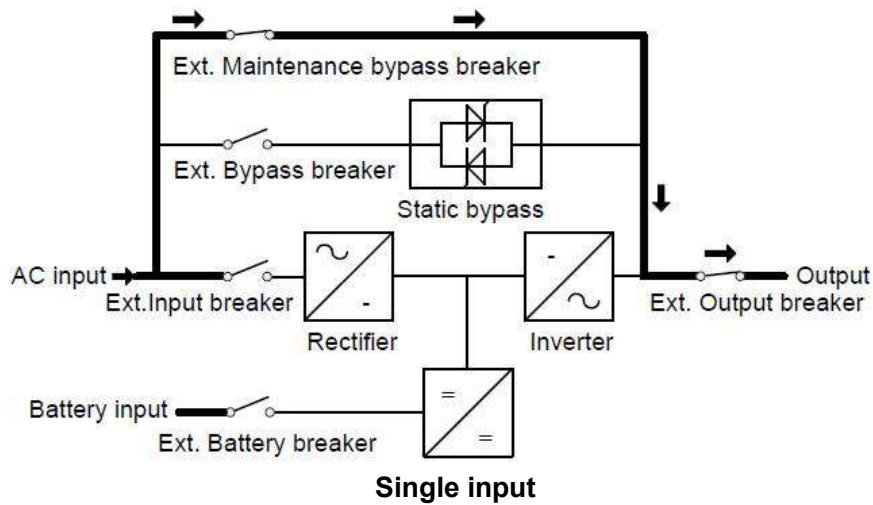

4.2 Turn on/off UPS

4.2.1 Restart procedure



CAUTION!

MAKE SURE GROUNDING IS PROPERLY DONE!

- ◆ Set the Battery Breaker to the “ON” position according to the user’s manual.



CAUTION!

Check to see if the load is safely connected with the output of the UPS. If the load is not ready to receive power from the UPS, make sure that it is safely isolated from the UPS output terminals

- ◆ Turn ON OUTPUT breaker of the PDU.
- ◆ Turn ON BYPASS breaker and MAINS breaker of the PDU.

If the Rectifier input is within voltage range, the rectifier will start up in 30 seconds then the inverter will start up after then.

If the rectifier fails at startup, the bypass LED will light up. When the inverter starts up, the UPS will transfer from bypass mode to inverter mode, then the bypass LED extinguishes and the inverter LED lights up.

No matter whether the UPS can work normally or not, all the status will be shown on the LCD display.

4.2.2 Test procedure



CAUTION!

The UPS is operating normally. It may take 60 seconds to boost up the system and perform self-test completely.

- ◆ Switch off the MAINS to simulate utility failure, the rectifier will turn off and the battery should feed the inverter without interruption. At this time, the LEDs of battery should be turned on.

- ◆ Switch on the MAINS to simulate utility recovery, the rectifier will restart automatically after 20 seconds and the inverter will supply to the load. It is suggested to use Dummy loads for testing. The UPS can be loaded up to its maximum capacity during load test ◦

4.2.3 MAINTENANCE BYPASS

To supply the load via Mains, you may simply active the internal mechanical bypass switch.



CAUTION!

The load is not protected by the UPS when the internal mechanical bypass system is active and the power is not conditioned.

Switch to mechanical bypass CAUTION!



If the UPS is running normally and can be controlled through the display, carry out steps 1 to 6; otherwise, jump to Step 5.

- ◆ Open the cover of maintenance switch, the UPS turns to bypass mode automatically.
- ◆ Turn on MAINTANCE breaker of the PDU;
- ◆ Switch OFF BATTERY breaker of the PDU;
- ◆ Switch OFF MAINS breaker of the PDU;
- ◆ Switch OFF BYPASS breaker of the PDU;
- ◆ Switch OFF OUTPUT breaker of the PDU;

At this time the bypass source will supply to the load through the MAINTENANCE breaker.

Switch to normal operation (from mechanical bypass)



CAUTION!

Never attempt to switch the UPS back to normal operation until you have verified that there are no internal UPS faults.

- ◆ Turn ON OUTPUT breaker of the PDU.
- ◆ Turn ON BYPASS breaker of the PDU.

- ◆ Turn ON MAINS breaker of the PDU.

The UPS powers from the static bypass instead of the maintenance bypass, then the bypass LED will light up.

- ◆ Switch OFF the maintenance bypass breaker, then the output is supplied by the static bypass of the UPS.
- ◆ Put on the maintenance switch cover.

The rectifier will operate normally after 30 seconds. If the inverter works normally, the system will be transferred from bypass mode to normal mode.

4.2.4 Cold start procedure



CAUTION!

Follow these procedures when the input AC Utility Failure, but battery is normal

- ◆ Turn on the BATTERY breaker.
The battery will feed the Auxiliary power board.
- ◆ Turn on the OUTPUT breaker.
- ◆ Trigger the cold start(Cold start) button as the position 11 of the below drawing.

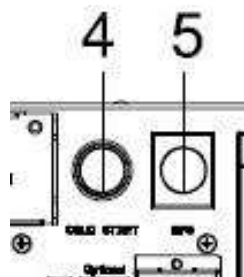

When battery normal, rectifier starts operation, 30s later, inverter starts and operates and battery LED on.



CAUTION!

Please press the close start button after 30 seconds until closing the battery switch.

4.2.5 Shut down procedure



CAUTION!

This procedure should be followed to completely shut down the UPS and the LOAD. After all power switches, isolators and circuit breakers are opened, there will be no output.

- ◆ Switch OFF the BATTERY breaker ;
- ◆ Open the UPS door to easily access to the main power switch ;
- ◆ Switch OFF the MAINS breaker.
- ◆ Switch OFF the BYPASS breaker.
- ◆ Open the OUTPUT breaker. The UPS shuts down ;

- ◆ To completely isolate the UPS from AC Mains, all input switches of Utility shall be completely off, which includes the ones for rectifier and bypass.
- ◆ The primary input distribution panel, which is often located far away from the UPS area, so a label should be posted to advise service personnel that the UPS circuit is under maintenance.



WARNING!

Wait for about 5 minutes for the internal D.C. bus bar capacitors to be completely discharged.

4.2.6 Parallel setting

- ◆ Connect the UPS with computer. Power on the UPS.
- ◆ Open Muser5000 software, after connecting with the UPS successfully, click “System”->“User Set”



- ◆ Click “Set” at “User Set” window. Password is YDC3350.

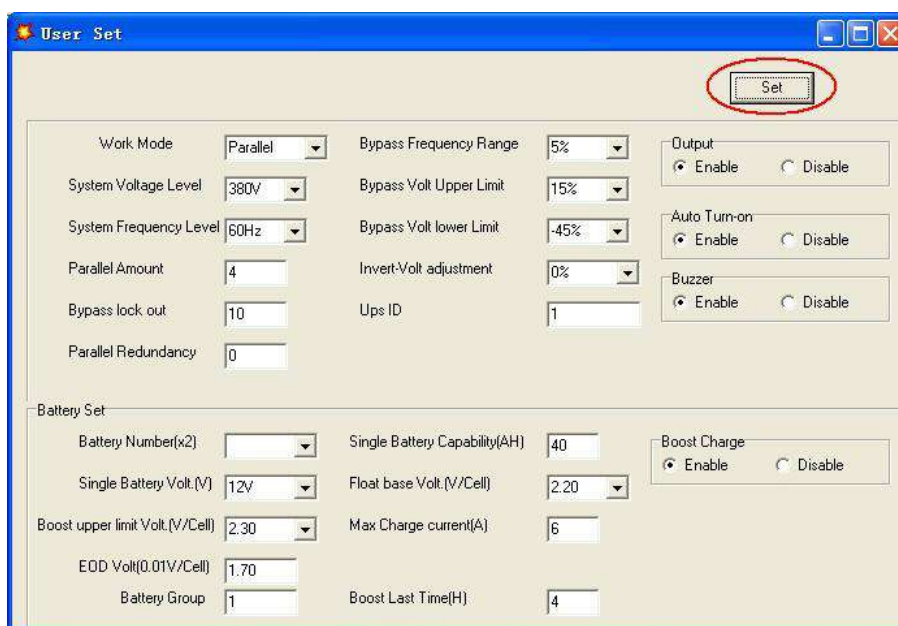

◆ At the window of “Data Set”, click “Work Mode”, choose “Parallel” for the value, then click “Set” as shown in below picture. If the UPS sounds a “beep”, that means the setting is correct.

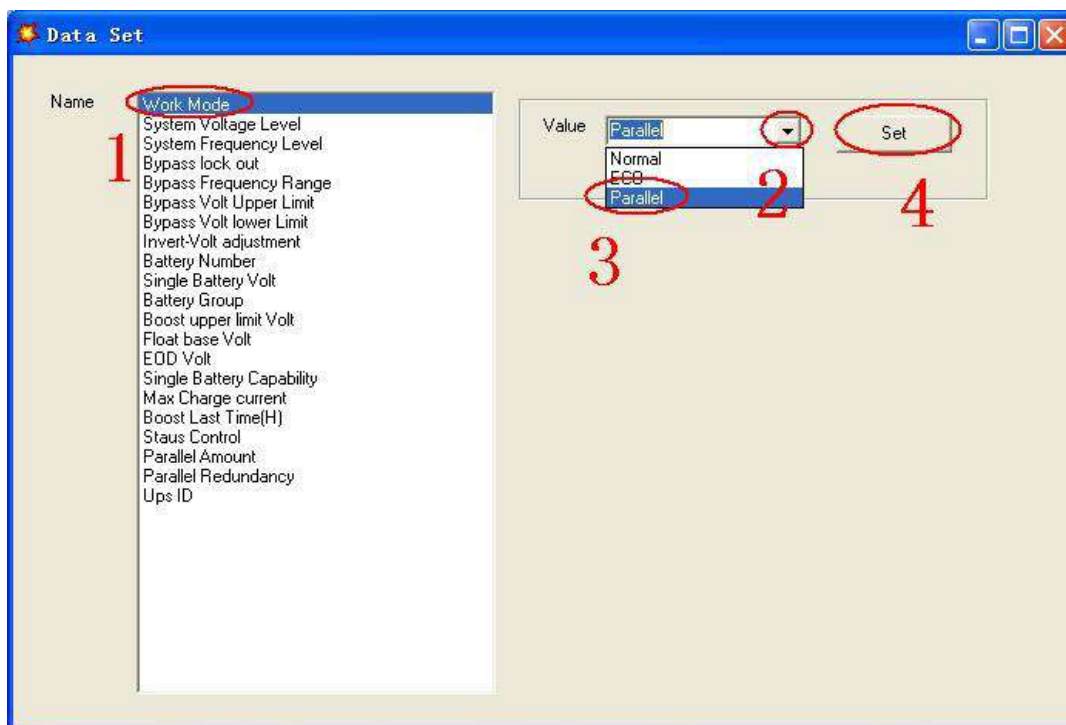

◆ At the window of “Data Set”, click “Ups ID”, write a value for the parallel UPS ID at the right side, such as “1”, then click “Set” as shown in below picture. If the UPS sounds a “beep”, that means the setting is correct.

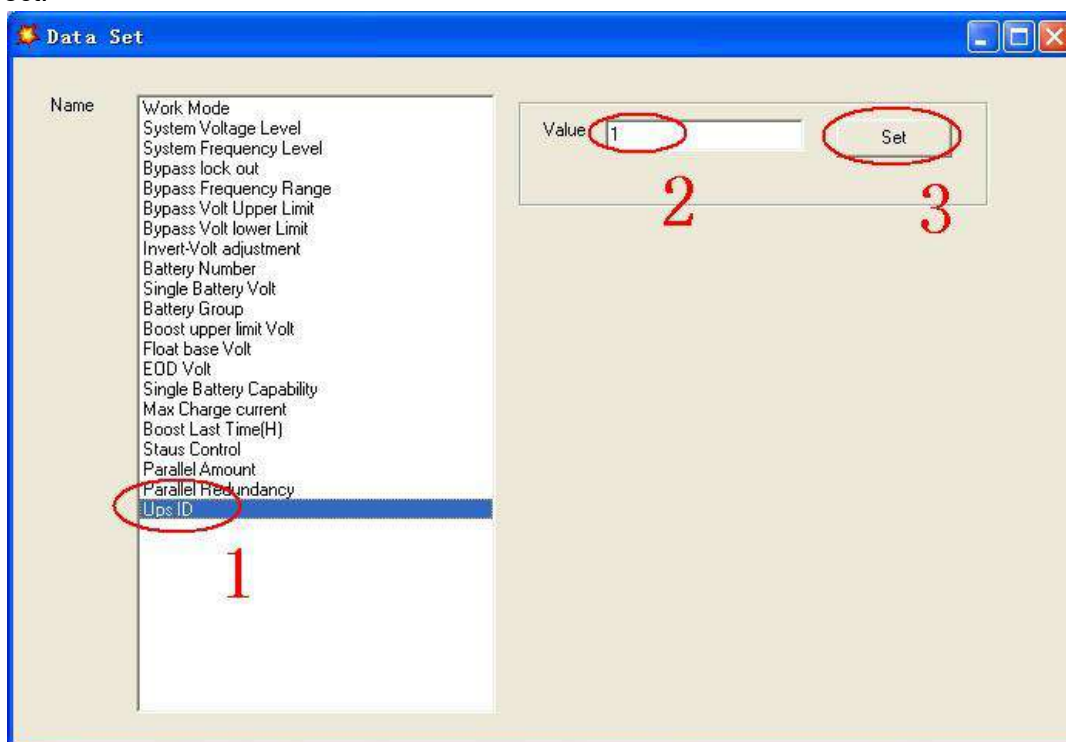

CAUTION!



After changing the parallel system ID, the connection between Muser5000 and equipment might be interrupted. If it occurs, please re-connect in accordance with the instruction described before.



CAUTION!

Parallel cable cannot be connected when setting the parallel parameters.

- ◆ After setting the UPS needed to be paralleled, power off all the UPS. Connect all the UPS according to “parallel cable installation”, and then power on the UPS.

4.3 The LCD Display

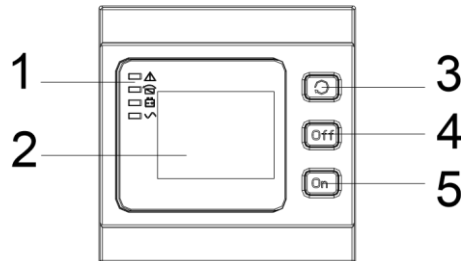

Overview of the operating panel of the UPS

- (1) LED indicator
- (2) LCD display
- (3) Scroll button: enter to next item
- (4) Off button (5) On button

Introduction



CAUTION!

The display provides more functions than those described in this manual.

Main page : default display page

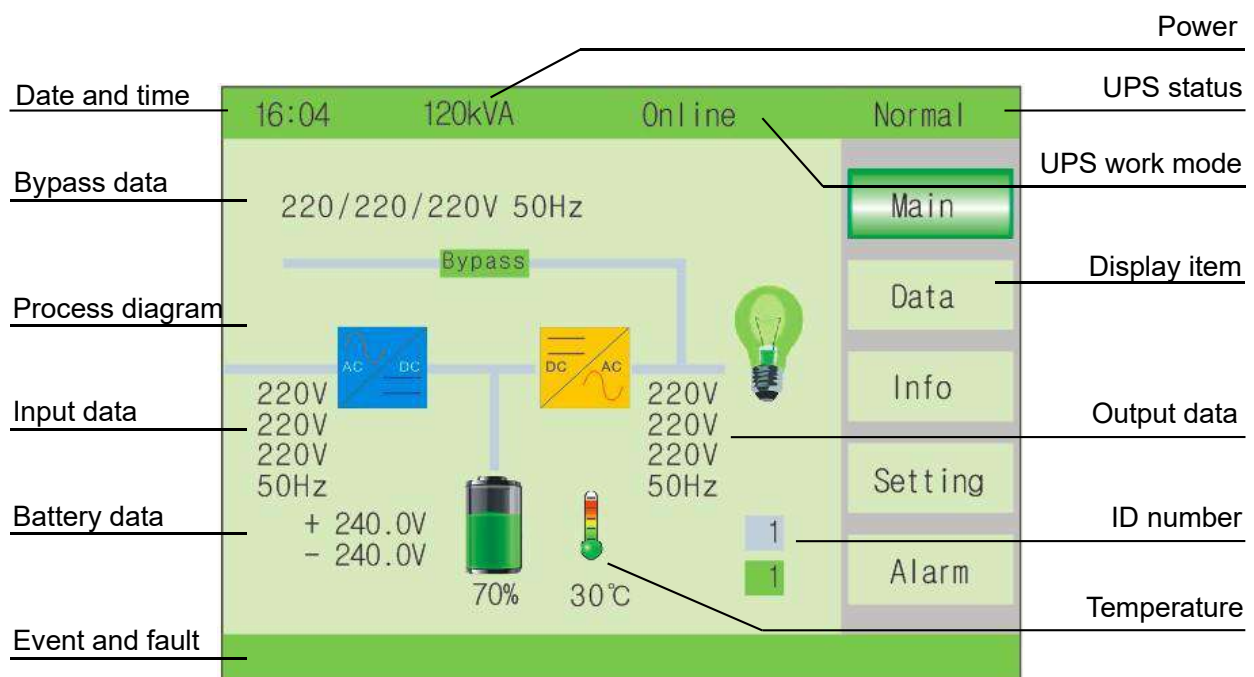

Data : press  key for short time change to data item, the page display input data and output data

16:04	120kVA	Online	Normal
Data-Input			
V	220.0	220.0	220.0V
I	3	3	3A
F	50.0Hz		
Data-Output			
V	220.0	220.0	220.0V
I	0	0	0A
F	50.0Hz		
load	0	0	0%
Main			
Data			
Info			
Setting			
Alarm			

INPUT : press Off key for short time to enter the data, the first page is mains input and bypass input data.

16:04	120kVA	Online	Bypass
Data-Main			
V	220.0	220.0	220.0V
I	3	3	3A
F	50.0Hz		
Data-Bypass			
V	220.0	220.0	220.0V
F	50.0Hz		
Input			
Output			
Battery			
Load			
Inside			

OUTPUT : press ↻ key for short time to change item, the second page of data is Output data.



16:04	120kVA	Online	Normal
Data-Output			
V	220.0	220.0	220.0V
I	0	0	0A
F	50.0Hz		
			Input
			Output
			Battery
			Load
			Inside

Battery : press ↻ key for short time to change item, the third page of data is Battery data.



16:04	120kVA	Online	Normal
Data-Battery			
V	+240	-240V	
I	10	10A	
Time	200 min		
CaP.	70 %		
Temp.	25 °C		
			Input
			Output
			Battery
			Load
			Inside

LOAD: : press  key for short time to change item, the fourth page of data is Load data.

16:04		120kVA		Online		Normal	
Data-Load							
%	0	0	0%	<input type="button" value="Input"/> <input type="button" value="Output"/> <input type="button" value="Battery"/> <input type="button" value="Load"/> <input type="button" value="Inside"/>			
P	0	0	0kW				
S	0	0	0kVA				

INFO: : Press  key for long time to exit data item, and press  key for short time change to Info item, this page display the version of the LCD/LED and DSP

16:04		120kVA		Online		Normal	
Information							
Monitor Ver.	V004B001D000			<input type="button" value="Main"/> <input type="button" value="Data"/> <input type="button" value="Info"/> <input type="button" value="Setting"/> <input type="button" value="Alarm"/>			
LCD Ver.	V001B345D000						
REC DSP Ver.	V001B345D000						
REC CPLD Ver.	V001B345D000						
INV DSP Ver.	V001B345D000						
INV CPLD Ver.	V001B345D000						
ECU DSP Ver.	V001B345D000						
ECU CPLD Ver.	V001B345D000						

SETTING-User: press  key for short time change to setting item, then press OFF key to enter setting-user page. Press  key to change item, press off key to enter item and press  key to change value, press OFF key confirm the setting.

Lang : Language display, default value is "English".

Date : date setting

Time : time setting

Backlight : backlight delay time setting, default value is "60s"



Buzzer : buzzer tweet or mute, default value is "tweet"

Test now : battery self-test, test 10 second, 10 minute or to eod, default value is "OFF"

Device ID : default value is "1"

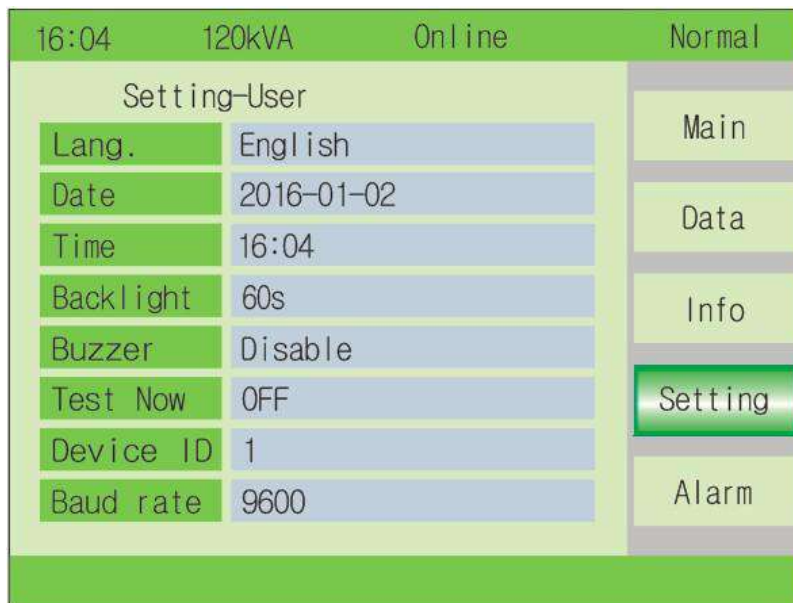
Baud rate : can select 2400, 4800 or 9600, default value is "9600"



Maintenance : Press  + off key to enter maintenance, then will display a password window, press  change the number and press off to select the value, the password is "1121".



Maintenance-System : press OFF key to enter item and confirm value, press  change value.

Work mode : Normal, Parallel, ECO, default value is "Normal"

V_ Output Grade : 220/230/240, default value is "220"

F_ Output Grade : 50 and 60, default value is "50"

F_ mode : CVCF and Non-CVCF, default value is "Non-CVCF"

Test type : 10s, 10min and EOD, default value is "OFF"

Test Circle : 1~30 days

Temp. Sensor SW : ON or OFF, default value is "OFF" OFF means turn off the sensor switch, ON means turn on the sensor switch, send query command to sensor with address 11,12 every second.

O/P Volt : Inverter voltage Micro regulation, $0 \sim \pm 5\%$, step is 0.5%, default value is "0"

16:04 120kVA Online Normal	
Setting-System	
Work Mode	Parallel
V Output Grade	220V
F Output Grade	50Hz
F Mode	non-CVCF
Test Type	OFF
Test Circle	30 Day
Temp.Sensor SW	OFF
O/P Volt	0%

Maintenance-Bypass : press OFF key to enter item and confirm value, press ↻ change value.

Upper Limit : 5%, 10%, 15%, 20%, 25%, default value is "25%"

Lower Limit : -10%, -20%, -30%, -45%, default value is "-45%"

F_Range : 1%, 2%, 4%, 5%, 10%, default value is "10%"

Times of INV-BPS : 3~10, default value is "10"

Limit by Temp. : Enable/disable, default value is "Enable"

16:04 120kVA Online Normal	
Setting-Bypass	
Upper Limit	+20%
Lower Limit	-45%
F range	10%
Times of INV-BPS	10
Limit by Temp.	Disable

Maintenance-Battery : press OFF key to enter item and confirm value, press ↻ change value.

Number : 30/32/34/36/38/40/42/44/46/48/50pcs (15/16/17/18/19/20/21/22/23/24/25pcs for each "+" string and "-" string.) default value is "30"

Capacity : 7~2000Ah

Boost charge : Enable or disable, default value is "Enable"

Group : 1~8, default value is "1"

V-Boost : 2.30~2.40, step is 0.01V, default value is "2.30"

V-Float : 2.20~2.29, step is 0.01V, default value is "2.25"

V-EOD : 1.60V or 1.80V, step is 0.01V, default value is "1.8"

I-Maxcharge : 0.05~0.15C

16:04	120kVA	Online	Normal
Setting-Battery			
Number	10 PCS		System
Capacity	65 Ah		Bypass
Boost Charge	Enable		Battery
Group	1		Parall.
V-Boost	2.30		Other
V-Float	2.25		
V-EOD	1.75		
I-MaxCharge	0.15C		

Maintenance-Parallel : This item can select after the work mode is set parallel. Press OFF key to enter item and confirm value, press ↻ change value.

ID : 1~6. UPS ID. default value is "1"

Number : 1~6, UPS parallel max number, default value is "1"

Redu. Num : 1~5, redundancy UPS number, default value is "0"

16:04	120kVA	Online	Normal
Setting-Parallel			
ID	1		System
Number	3		Bypass
Redu. Num.	1		Battery
			Parall.
			Other

Alarm : Contain alarm record and event record

16:04	120kVA	Online	Fault
System-Alarm			Alarm
108-01	No battery		Record
No battery			

16:04	120kVA	Online	Fault
Record			Alarm
Index	1		Record
Type	1		
Time	2016-01-02 16:04		
State	On-line		
Event	Input breaker closed		
Alarm	108-1		
	No Battery		
Fault			

4.4 Display Messages/Troubleshooting

This section lists the event and alarm messages that the UPS might display. The messages are listed in alphabetical order. This section is listed with each alarm message to help you troubleshoot problems.

Display messages Operational Status and Mode(s)

No.	Information stand for	LED			
		Fault	Bypass	Battery	Inverter
1	Initialized	EXTINGUISH	EXTINGUISH	EXTINGUISH	EXTINGUISH
2	Standby Mode	EXTINGUISH	EXTINGUISH	X	EXTINGUISH
3	No Output	EXTINGUISH	EXTINGUISH	X	EXTINGUISH
4	Bypass Mode	EXTINGUISH	LIGHT	X	EXTINGUISH
5	Utility Mode	EXTINGUISH	EXTINGUISH	X	LIGHT
6	Battery Mode	EXTINGUISH	EXTINGUISH	LIGHT	EXTINGUISH
7	Battery Self-diagnostics	EXTINGUISH	EXTINGUISH	LIGHT	EXTINGUISH
8	Inverter is starting up	EXTINGUISH	X	X	EXTINGUISH
9	ECO Mode	EXTINGUISH	X	X	X
10	EPO Mode	LIGHT	EXTINGUISH	X	EXTINGUISH
11	Maintenance Bypass Mode	EXTINGUISH	EXTINGUISH	EXTINGUISH	EXTINGUISH
12	Fault Mode	LIGHT	X	X	X

CAUTION : "X" means it is determined by other conditions

Fault Information

No	Fault Cord	UPS Alarm Warning	Buzzer	LED
1	002	REC Over Temperature	Twice per second	Fault LED lit
2	003	REC par. cable Fault	Twice per second	Fault LED lit
3	004	REC Over Current	Beep continuously	Fault LED lit
4	005	REC Power Fault	Beep continuously	Fault LED lit
5	007	Input SCR Fault	Beep continuously	Fault LED lit
6	00A	Battery SCR Fault	Beep continuously	Fault LED lit
7	00C	Charge SCR Fault	Beep continuously	Fault LED lit
8	00E	Fan Fault	Beep continuously	Fault LED lit
9	011	Fan Power fault	Beep continuously	Fault LED lit
10	012	Charger Over Temp.	Beep continuously	Fault LED lit
11	013	Soft Start Failed	Beep continuously	Fault LED lit
12	014	BAT Charger Fault	Beep continuously	Fault LED lit
13	016	REC Comm. Fault	Once per 2 seconds	Fault LED blinking
14	019	REC Initializes Fault	Beep continuously	Fault LED lit
15	01D	Unit insert fault	Once per 2 seconds	Fault LED lit
16	063		Once per 2 seconds	Fault LED lit

No	Fault Cord	UPS Alarm Warning	Buzzer	LED
17	01E	Rectifier Fault	Beep continuously	Fault LED lit
18	041	Inverter Fault	Beep continuously	Fault LED lit
19	044	INV IGBT SHORT	Beep continuously	Fault LED lit
20	047	Inverter relay Short	Beep continuously	Fault LED lit
21	04A	Inverter relay Broken	Beep continuously	Fault LED lit
22	04D	INV par. cable Fault	Twice per second	Fault LED lit
23	051	Output Short Circuit	Once per second	Fault LED blinking
24	054	INV Comm. Fault	Once per 2 seconds	Fault LED blinking
25	057	INV Initializes Fault	Beep continuously	Fault LED lit
26	05A	INV self-test Fault	Beep continuously	Fault LED lit
27	05E	DC Component Fault	Once per 2 seconds	Fault LED lit
28	061	DC bus abnormal	Beep continuously	Fault LED lit
29	064	INV DSP Power Fault	Beep continuously	Fault LED lit
30	067	INV Over Temperature	Twice per second	Fault LED lit
31	068	Load Sharing Fault	Twice per second	Fault LED lit
32	06A	Cabinet mode Fault	Beep continuously	Fault LED lit
33	06B	Fuse Broken	Beep continuously	Fault LED lit
34	081	Par. cable Fault	Twice per second	Fault LED lit
35	086	ECU Insert Fault	Once per 2 seconds	Fault LED lit
36	088	ECU Power Fault	Beep continuously	Fault LED lit
37	08B	ECU Comm. Fault	Beep continuously	Fault LED lit
38	08D	ECU Initializes Fault	Once per 2 seconds	Fault LED blinking
39	091	Bypass SCR Broken	Beep continuously	Fault LED lit
40	0C2		Beep continuously	Fault LED lit
41	094	Bypass SCR short	Beep continuously	Fault LED lit
42	0C5		Beep continuously	Fault LED lit
43	097	BPS Over Temperature	Beep continuously	Fault LED lit
44	0CF		Beep continuously	Fault LED lit
45	09A	Output CT Reverse	Beep continuously	Fault LED lit
46	09D	Bypass Feedback Fault	Beep continuously	Fault LED lit

Alarm Information

No	Alarm Cord	UPS Alarm Warning	Buzzer	LED
1	103	Battery Over Voltage	Once per second	BATTERY LED blinking
2	104	BAT Low Pre-warning	Once per second	BATTERY LED blinking
3	105	Battery Reverse	Twice per second	BATTERY LED blinking
4	106	Battery EOD	Once per second	BATTERY LED blinking
5	107	Battery Voltage low	Once per second	BATTERY LED blinking

No	Alarm Cord	UPS Alarm Warning	Buzzer	LED
6	108	No Battery	Once per second	BATTERY LED blinking
7	109	Input Phase Reverse	Once per second	INVERTER LED blinking
8	10A	Input N-Line lost	Twice per second	INVERTER LED blinking
9	10B	Mains Freq. Abnormal	Once per 2 seconds	INVERTER LED blinking
10	10C	Mains Volt. Abnormal	Once per 2 seconds	INVERTER LED blinking
11	10D	REC Comm. Error	Once per 2 seconds	INVERTER LED blinking
12	10E	Mains input lost	Once per 2 seconds	
13	10F	Set Data Err.	Once per 2 seconds	FAULT LED blinking
14	121	INV Par. cable abnormal	Once per 2 seconds	FAULT LED blinking
15	125	INV Overload	Once per 2 seconds	INVERTER LED blinking
16	126	INV not synchronized	Beep continuously	INVERTER LED blinking
17	12A	INV Set Data Err	Once per 2 seconds	FAULT LED blinking
18	129	INV Comm. Error	Once per 2 seconds	FAULT LED blinking
19	141	Bypass Switch to Num	Once per 2 seconds	BYPASS LED blinking
20	142	Unit quantity mismatch	Once per 2 seconds	FAULT LED blinking
21	143	Parallel Overload	Once per 2 seconds	INVERTER LED blinking
22	144	Bypass Overload	Once per 2 seconds	BYPASS LED blinking
23	145	Maint. Switch Misuse	Once per 2 seconds	FAULT LED blinking
24	146	ECU Comm. Error	Once per 2 seconds	FAULT LED blinking
25	147	Par. cable abnormal	Once per 2 seconds	FAULT LED blinking
26	14B	ECU Par. cable abnormal	Once per 2 seconds	FAULT LED blinking
27	14C	ECU Abnormal	Once per 2 seconds	FAULT LED blinking
28	14E	BPS Phase Reversed	Once per second	BYPASS LED blinking
29	162		Once per second	BYPASS LED blinking
30	14F	BPS Unable To Trace	Once per 2 seconds	BYPASS LED blinking
31	163		Once per 2 seconds	BYPASS LED blinking
32	150	BPS Not Available	Once per second	BYPASS LED blinking
33	164		Once per second	BYPASS LED blinking
34	151	Ecu Set Data Err	Once per 2 seconds	FAULT LED blinking

4.5 Options

SNMP card: internal SNMP / external SNMP optional

- ◆ Loosen the 2 torque screws (on each side of the card).
- ◆ Carefully pull out the card. Reverse the procedure for re-installation

The slot called SNMP supports the MEGAtec protocol. We advise that NetAgent II-3 port is also a tool to remotely monitor and manage any UPS system

NetAgent II-3Ports supports the Modem Dial-in (PPP) function to enable the remote control

Appendix 1 Specifications

MODEL	10kVA	15kVA	20kVA	25kVA	30kVA	40kVA	50kVA
Capacity (VA/Watts)	10k 10k	15k 15k	20k 20k	25k 25k	30k 30k	40k 40k	50k 50k
INPUT							
Nominal voltage	380/400/415Vac, (3Ph+N+PE)						
Operating voltage range	138~485Vac						
Operating frequency range	40Hz-70Hz						
Power factor	≥0.99						
Harmonic distortion (THDi)	≤3% (100%non-linear load)						
Bypass voltage range	220Vac Max.voltage: +25%(optional +10%,+15%,+20%) 230Vac Max.voltage: +20%(optional +10%,+15%) 240Vac Max.voltage: +15%(optional +10%) Min. voltage: - 45% (optional -20%,-30%) Frequency synchronize tracing range: ±10%						
Generator input	Support						
OUTPUT							
Output voltage	380/400/415Vac (3Ph+N+PE)						
Voltage regulation	±1%						
Power factor	1.0						
Output frequency	1.Line Mode: synchronize with input; when input frequency >±10% (±1%/±2%/±4%/±5% optional) 2.Battery Mode:50/60*(1±0.02%)Hz						
Crest factor	3:1						
Harmonic distortion (THD)	≤2% with linear load ≤4% with non linear load						
Efficiency	95.5%						
BATTERY							
Battery voltage	Optional Voltage: ±180V/±192V/±204V/±216V/±228V/±240/±252/±264/±276/±288/ ±300Vdc(30/32/34/36/38/40/42/44/46/48/50pcs optional) 360Vdc~600Vdc (30~50 pcs, 30 pcs define, 36~50 pcs no power derating; 32~34 pcs output power factor 0.9; 30 pcs output power factor 0.8;)						
Charge Current(A) (charge current can be set according to battery capacity installed)	Max. current 13A			Max. current 20A			
SYSTEM FEATURES							
Transfer time	Utility to Battery : 0ms; Utility to bypass: 0ms						
Overload	Load≤110%: last 60min,≤125%: last 10min,≤150%: last 1min						
Alarm	overload, utility abnormal, UPS fault, battery low, etc.						

Backfeed		Support			
Protection		short circuit, overload, over temperature, battery low, fan fault alarm.			
Communication	10-30kVA	USB, RS232, RS485, Parallel port, Dry contact port, REPO port, Backfeed port, Intelligent slot, SNMP card (optional)			
	40-50kVA	USB, RS232, RS485, Parallel port, REPO port, LBS port, Backfeed port, Intelligent slot, SNMP card (optional), Relay card (optional)			
ENVIRONMENTAL					
Operating temperature		0°C~40°C			
Storage temperature		-25°C~55°C(no battery)			
Humidity range		0~95% (non condensing)			
Altitude		< 1500m.When>1500m,lower the rated power for use			
Noise level		<55dB	<56dB	<58dB	<58dB
PHYSICAL					
Dimension D×W×H (mm)		670×440×130(3U)		800×440×175 (4U)	
Net weight (kg)		25	27~28	45	48
STANDARDS					
Safety		IEC/EN62040-1,IEC/EN60950-1			
EMC		IEC/EN62040-3,IEC61000-4-2,IEC61000-4-3,IEC61000-4-4,IEC 61000-4-5,IEC61000-4-6,IEC61000-4-8			

Appendix 2 Problems and Solution

In case the UPS cannot work normally, it might be wrong in installation, wiring or operation. Please check these aspects first. If all these aspects are checked without any problem, please consult with local agent right away and provide below information.

(1) Product model name and serial number.

(2) Try to describe the fault with more details, such as LCD display info, LED lights status, etc.

Read the user manual carefully, it can help a lot for using this UPS in the right way. Some FAQ (frequently asked questions) may help you to troubleshoot your problem easily.

No.	Problem	Possible reason	Solution
1	Utility is connected but the UPS cannot be powered ON.	Input power supply is not connected; Input voltage low; The input switch of the UPS is not switched on.	Measure if the UPS input voltage/frequency is within the window. Check if UPS input is switched on
2	Utility normal but Utility LED does not light on, and the UPS operates at battery mode	The input breakers of the UPS are not switched on; input cable is not well connected	Switch on the input breaker; Make sure the input cable is well connected.
3	The UPS does not indicate any failure, but output do not have voltage	Output cable does not well connected; Output breaker do not switch on	Make sure the output cable is well connected; Switch on the output breaker.
4	Utility LED is flashing	Utility voltage exceeds UPS input range.	If the UPS operates at battery mode, please pay attention to the remaining backup time needed for your system.
5	Battery LED is flashing but no charge voltage and current	Battery breaker does not switch on, or batteries are damaged, or battery is reversely connected. Battery number and capacity are not set correctly.	Switch on the battery breaker. If batteries are damaged, need to replace whole group batteries, Connect the battery cables correctly; Go to LCD setting of the battery number and capacity, set the correct data.
6	Buzzer beeps every 0.5 seconds and LCD display "output overload"	Overload	Remove some load
7	The UPS only works on bypass mode	The UPS is set to ECO mode, or the transfer times to bypass mode are limited.	Set the UPS working mode to UPS type(non-parallel) or to reset the times of transferring to bypass or re-start the UPS
8	Cannot Black start	Battery switch is not properly closed: Battery fuse is not open: Or Battery low: Battery quantity set wrong; Power breaker in the rear panel not switch ON.	Close the battery switch: Change the fuse: Recharge the battery: Power ON the UPS with AC to set the battery quantity & quantity; Switch on the power breaker.

Appendix 3 USB communication port definition

Definition of port :

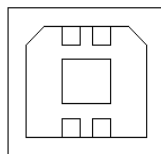

Connection between PC USB port and UPS USB port.

PC USB port	UPS USB port	Description
Pin 1	Pin 1	PC : +5V
Pin 2	Pin 2	PC : DPLUS signal
Pin 3	Pin 3	PC : DMINUS signal
Pin 4	Pin 4	Signal ground

Available function of USB

- ◆ Monitor UPS power status.
- ◆ Monitor UPS alarm info.
- ◆ Monitor UPS running parameters.
- ◆ Timing off/on setting.

Communication data format

Baud rate ----- 9600bps

Byte length ----- 8bit

End bit ----- 1bit

Parity check -----none



CAUTION!

USB and RS232 interface cannot be used at the same time, you can only use one of them at one time.

Appendix 4 RS232 communication port definition

Definition of Male port :

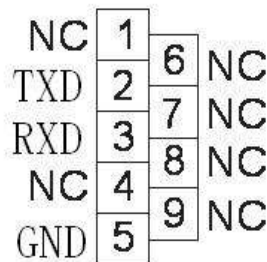

Connection between PC RS232 port and UPS RS232 port

PC RS232 port	UPS RS232 port	
Pin 2	Pin 2	UPS send,PC receive
Pin 3	Pin 3	PC send,UPS receive
Pin 5	Pin 5	ground

Available function of RS232

- ◆ Monitor UPS power status.
- ◆ Monitor UPS alarm info.
- ◆ Monitor UPS running parameters.
- ◆ Timing off/on setting.

RS-232 communication data format

Baud rate ----- 9600bps

Byte length ----- 8bit

End bit ----- 1bit

Parity check -----none



CAUTION!

USB and RS232 interface cannot be used at the same time, you can only use one of them at one time.

Appendix 5 RS485 communication port definition

Definition of port :

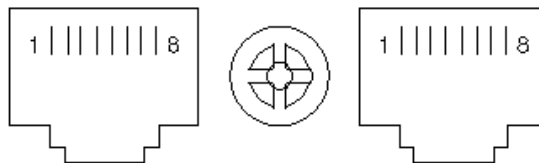

Connection between the Device's RS485 port and UPS RS485 port.

	device(RJ45)	UPS(RJ45)	Description
10-30kVA	Pin 1	Pin 1	485+ "A"
	Pin 2	Pin 2	485 -"B"
	Pin 7	Pin 7	12V
	Pin 8	Pin 8	GND
40-50kVA	Pin 1/5	Pin 1/5	485+ "A"
	Pin 2/4	Pin 2/4	485 -"B"
	Pin 7	Pin 7	12V
	Pin 8	Pin 8	GND

Available function of RS485

- ◆ Monitor UPS power status.
- ◆ Monitor UPS alarm info.
- ◆ Monitor UPS running parameters.
- ◆ Timing off/on setting.
- ◆ Battery environment temperature monitoring.
- ◆ Charging voltage modulation depending on batteries temperature

Communication data format

Baud rate ----- 9600bps

Byte length ----- 8bit

End bit ----- 1bit

Parity check -----none



CAUTION!
RS485 port pin7 is 12Vdc!

Appendix 6 Dry contact port definition

10-30kVA:

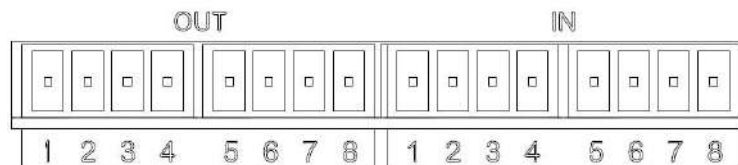

Input Dry Contact Interface

Port	Name	Function
IN-1	Input_contact_1	INV ON
IN-2	GND	Input dry contact signal GND
IN-3	Input_contact_2	INV OFF
IN-4	GND	Input dry contact signal GND
IN-5	Input_contact_3	Optional
IN-6	GND	Input dry contact signal GND
IN-7	Input_contact_4	Optional
IN-8	GND	Input dry contact signal GND

Output Dry Contact Interface

Port	Name	Function
OUT-1	Output_1_RLY	Output_1 dry contact port NC pin :Common alarm
OUT-2	Output_1_RLY_C	Output_1 dry contact port common pin
OU -3	Output_2_RLY	Output_2 dry contact port NC pin :Static bypass
OUT-4	Output_2_RLY_C	Output_2 dry contact port common pin
OUT-5	Output_3_RLY	Output_3 dry contact port NC pin :Battery voltage low
OUT-6	Output_3_RLY_C	Output_3 dry contact port common pin
OUT-7	Output_4_RLY	Output_4 dry contact port NC pin :On Line mode (INV. Output)
OUT-8	Output_4_RLY_C	Output4 dry contact port common pin

Appendix 7 Backfeed protection port definition

10-30kVA:

Definition of Male port:

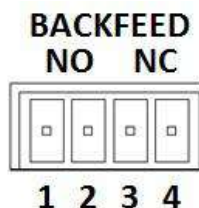

Instruction:

UPS	Instruction
Pin1/PIN2	Normally NO
Pin3/PIN4	Normally NC

Function description:

- ◆ Drive the bypass breaker when Backfeed alarm.

Appendix 8 Optional port definition

40-50kVA:

Definition of Male port :

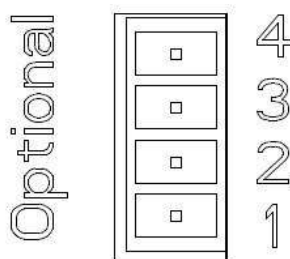

Instruction:

UPS	Instruction
Pin1	Normally NC
Pin2	Normally NO
Pin3	/
Pin4	Common

Function 1 description (Optional):

- ◆ Drive the bypass breaker when Backfeed alarm.

Function 2 description (Optional):

- ◆ Drive the battery breaker when battery voltage low.

Appendix 9 REPO instruction

Definition of port :

Connection diagram :

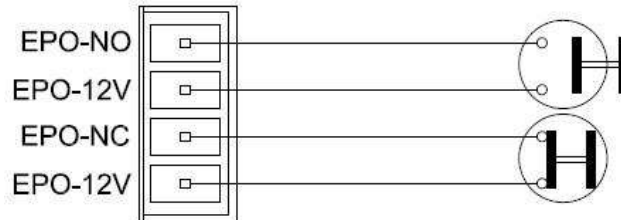

Connection between the button and UPS REPO port.

Button	UPS REPO	Description
Pin 1	Pin 1	EPO-NO
Pin 2	Pin 2	EPO-12V
Pin 1	Pin 3	EPO-NC
Pin 2	Pin 4	EPO-12V

- ◆ A remote emergency stop switch can be installed in a remote location and connection through simple wires to the REPO connector.

Appendix 10 Sub rack UPS dimension

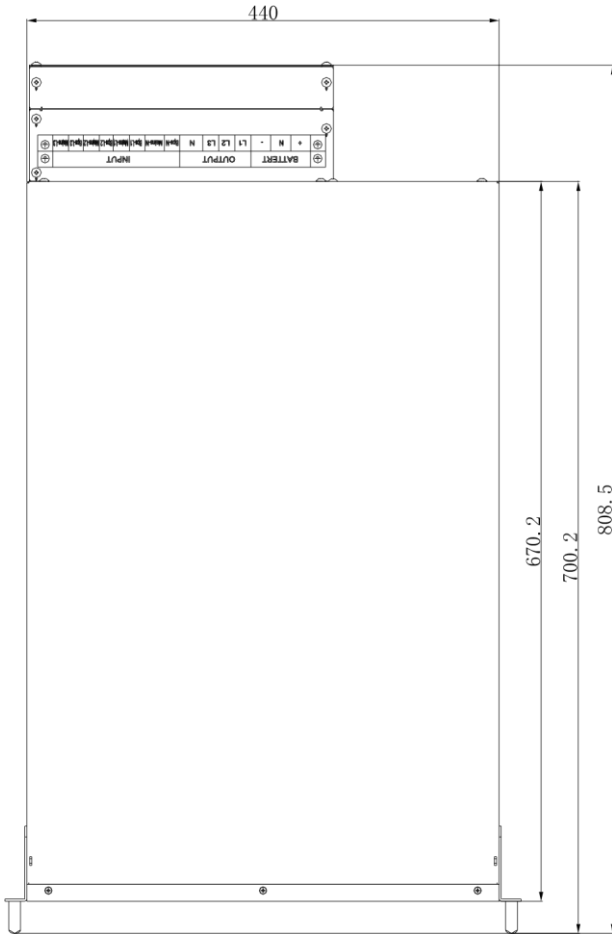
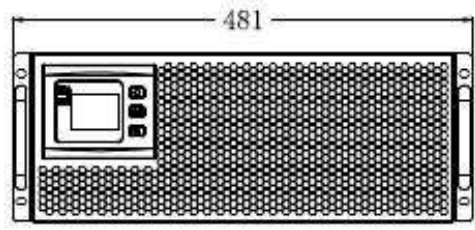
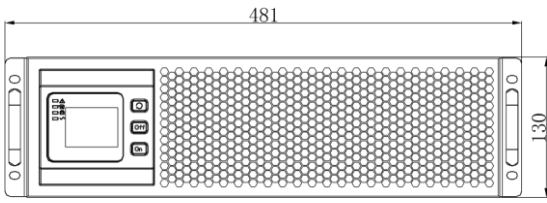

10/15/20/25/30kVA

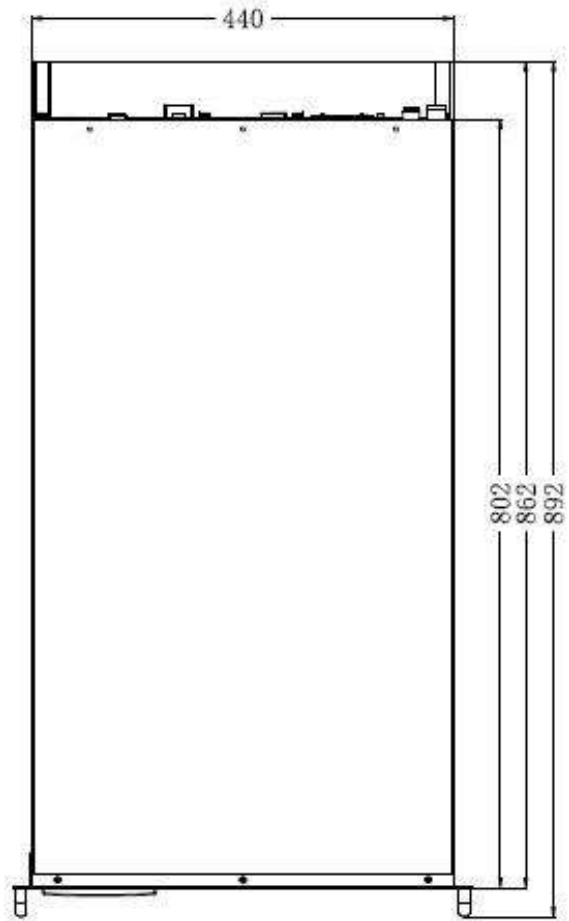

40/50kVA

Appendix 11 Tower UPS dimension

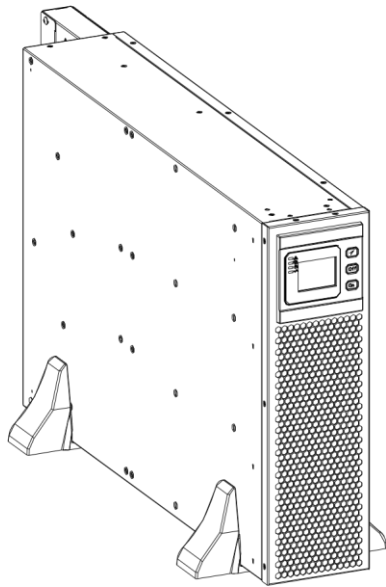

10/15/20/25/30kVA

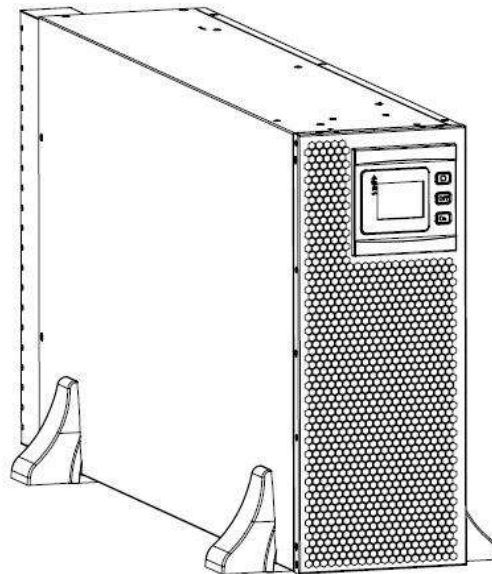

40/50kVA

10/15/20/25/30kVA:

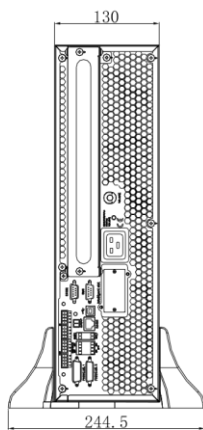

Rear view

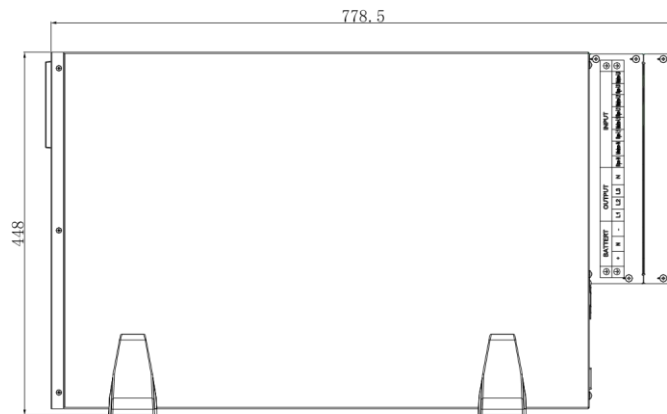

Side view

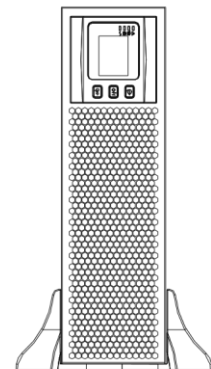

Front view

40/50kVA:

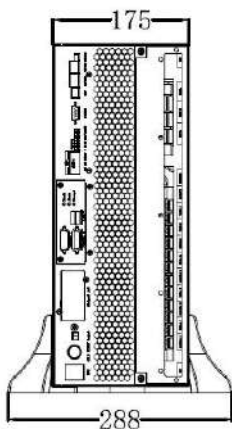

Rear view

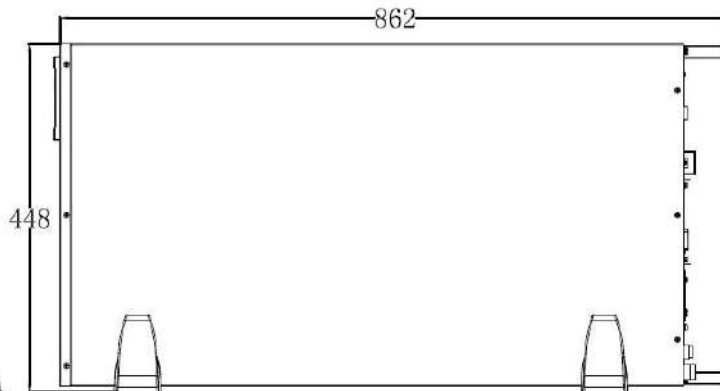

Side view

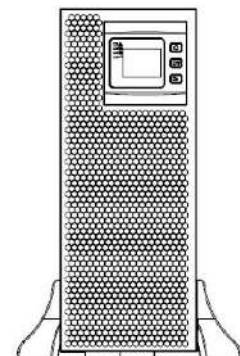

Front view

