



User Manual

RM11E PRO 1-3kVA (external)

Solutions behind the power

All rights reserved.

The information in this document is subject to change without notice.

Publish statement

Thank you for purchasing this series UPS.

This series UPS is an intelligent, single phase in single phase out, high frequency online UPS designed by our R&D team who is with years of designing experiences on UPS. With excellent electrical performance, perfect intelligent monitoring and network functions, smart appearance, complying with EMC and safety standards, The UPS meets the world' s advanced level.

Read this manual carefully before installation

This manual provides technical support to the operator of the equipment.

1:1



Table of Contents

1. Important Safety Warning	2
1-1 Transportation	2
1-2 Preparation	2
1-3 Installation	2
1-4 Operation	3
1-5 Maintenance, service and faults	3
1-6 Symbols used in this guide	4
2. Installation and setup	4
2-1 Unpack checking	4
2-2 Real panel view	5
2-3 Installing the UPS and EBPS	6
2-4 UPS startup and turn off	12
2-5 Set battery quantity	13
2-6 Operation and Display Panel	13
3. Operations	18
3-1 Button operation	18
3-2 Setup the UPS	19
3-3 LCD display	20
3-4 UPS setting	23
3-5 Operational Status and Mode(s)	26
3-6 Alarm or Fault reference code	27
4. Trouble shooting	29
5. Storage and Maintenance	32
6. Options	32
7. Specification	35

1. Important Safety Warning

Important safety instructions – Save these instructions

Please comply with all warnings and operating instructions in this manual strictly. Save this manual properly and read carefully the following instructions before installing the unit. Do not operate this unit before reading through all safety information and operating instructions carefully

There exists dangerous voltage and high temperature inside the UPS. During the installation, operation and maintenance, please abide the local safety instructions and relative laws, otherwise it will result in personnel injury or equipment damage. Safety instructions in this manual act as a supplementary for the local safety instructions. Our company will not assume the liability that caused by disobeyingsafety instructions.

1-1 Transportation

- Please transport the UPS system only in the original package to protect against shock and impact.

1-2 Preparation

- Condensation may occur if the UPS system is moved directly from cold to warm environment. The UPS system must be absolutely dry before being installed. Please allow at least two hours for the UPS system to acclimate the environment.
- Do not install the UPS system near water or in moist environments.
- Do not install the UPS system where it would be exposed to direct sunlight or near heater.
- Do not block ventilation holes in the UPS housing.

1-3 Installation

- Do not connect appliances or devices which would overload the UPS system (e.g. laser printers) to the UPS output sockets.
- Place cables in such a way that no one can step on or trip over them.
- Do not connect domestic appliances such as hair dryers to UPS output sockets.
- The UPS cannot be operated by any individuals with no previous experience.
- Connect the UPS system only to an earthed shockproof outlet which must be easily accessible and close to the UPS system.
- When installing the equipment, it should ensure that the sum of the leakage current of the UPS and the connected devices does not exceed 3.5mA.
- Before installing the ups, pay attention to the installation environment and do not install it in places with high temperature, humidity, and dust etc;

- The ups should reserve sufficient heat dissipation channels and be careful not to let other objects block the front and rear panels. It's recommended to leave at least 50cm space in front and back of the UPS for heat dissipation.

1-4 Operation

- Do not disconnect the mains cable on the UPS system or the building wiring outlet (shockproof socket outlet) during operations since this would cancel the protective earthing of the UPS system and of all connected loads.
- The UPS system features its own, internal current source (batteries). The UPS output sockets or output terminals block may be electrically live even if the UPS system is not connected to the building wiring outlet.
- In order to fully disconnect the UPS system, first press the OFF/Enter button to disconnect the mains.
- Prevent no fluids or other foreign objects from inside of the UPS system.

1-5 Maintenance, service and faults

- The UPS system operates with hazardous voltages. Repairs may be carried out only by qualified maintenance personnel.
- **Caution** - risk of electric shock. Even after the unit is disconnected from the mains (building wiring outlet), components inside the UPS system are still connected to the battery and electrically live and dangerous.
- Before carrying out any kind of service and/or maintenance, disconnect the batteries and verify that no current is present and no hazardous voltage exists in the terminals of high capability capacitor such as BUS-capacitors.
- Only persons are adequately familiar with batteries and with the required precautionary measures may replace batteries and supervise operations. Unauthorized persons must be kept well away from the batteries.
- **Caution** - risk of electric shock. The battery circuit is not isolated from the input voltage. Hazardous voltages may occur between the battery terminals and the ground. Before touching, please verify that no voltage is present!
- Batteries may cause electric shock and have a high short-circuit current. Please take the precautionary measures specified below and any other measures necessary when working with batteries:
 - remove wristwatches, rings and other metal objects
 - use only tools with insulated grips and handles.
- When changing batteries, install the same number and same type of batteries.
- Do not attempt to dispose of batteries by burning them. This could cause battery explosion.
- Do not open or destroy batteries. Escaping electrolyte can cause injury to the skin

and eyes. It may be toxic.

- Please replace the fuse only with the same type and amperage in order to avoid fire hazards.
- Do not dismantle the UPS system.

1-6 Symbols used in this guide



WARNING!

Risk of electric shock



CAUTION!

Read this information to avoid equipment damage

2. Installation and setup

NOTE: Before installation, please inspect the unit. Be sure that nothing inside the package is damaged. Please keep the original package in a safe place for future use.

2-1 Unpack checking

- Don't lean the UPS when moving it out from the packaging.
- Check the appearance to see if the UPS is damaged or not during the transportation, do not switch on the UPS if any damage found. Please contact the dealer right away.
- Check the accessories according to the packing list and contact the dealer in case of missing parts.

It includes:

- (1) UPS user's guide
- (2) USB cable(option)
- (3) RS232 cable(option)
- (4) Power cord
- (5) Mounting ears
- (6) Plastic base bracket
- (7) Rail kit(option)

2-2 Real panel view

1KVA:

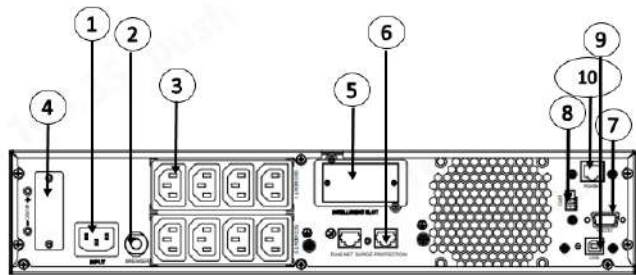

2KVA:

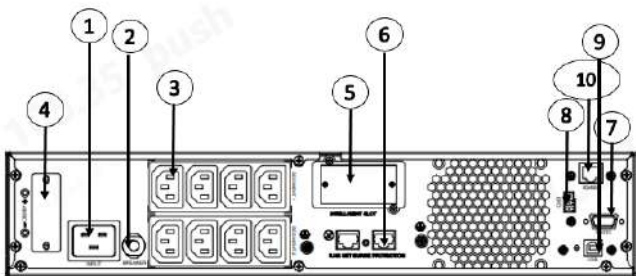

3KVA:

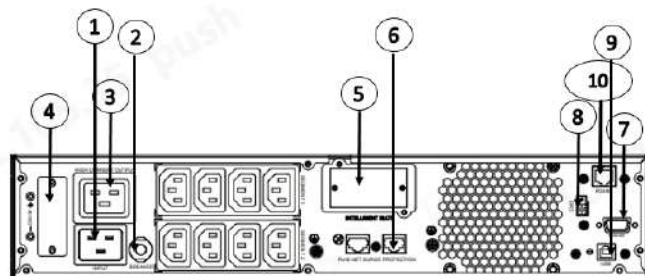

1. AC Input
2. Input circuit breaker
3. Output receptacles
4. Battery Terminal
5. SNMP intelligent slot
6. Network /Fax/Modem Surge Protection
7. RS232 communication port
8. EPO
9. USB
10. EPB COM
11. Output circuit breaker

2-3 Installing the UPS and EBPS

● Rackmount installation

The Rackmount cabinet comes with all of the hardware required for installation in a standard EIA or JIS seismic Rackmount configuration with square and round mounting holes. The rail assemblies adjust to mount in 19" racks with a distance from front to rear around 70~76 cm (27 to 30 inches) deep.

CAUTION



- *The cabinet is heavy. Removing the cabinet from its carton requires a minimum of two people.*
- *If installing optional EBP(S), make sure to install the EBP(S) directly below the UPS so that all wiring between the cabinets is installed behind the front covers and inaccessible to users.*

NOTE *Mounting rails are required for each individual cabinet*

(1) To install the rail kit

- a) Assemble the left and right rails to the rear rails as shown in Figure 1. Do not tighten the screws.

Adjust each rail size for the depth of your rack.

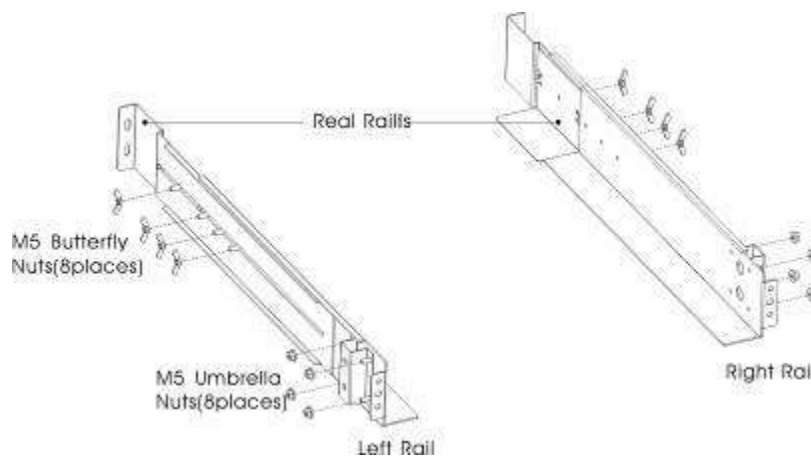

Figure 1 Securing the Rails

- b) Select the proper size in the rack for positioning the UPS (see Figure 2). The rail occupies four positions on the front and rear of the rack.
- c) Tighten four M5 Umbrella Nuts in the side of rail assembly (see Figure 1).
- d) Fix one rail assembly to the front of the rack with one M5×12 pan-head screw and one M5 cage nut. Using two M5 cage nuts and two M5×12 pan-head screws, to fix the rail assembly to the rear of the rack.

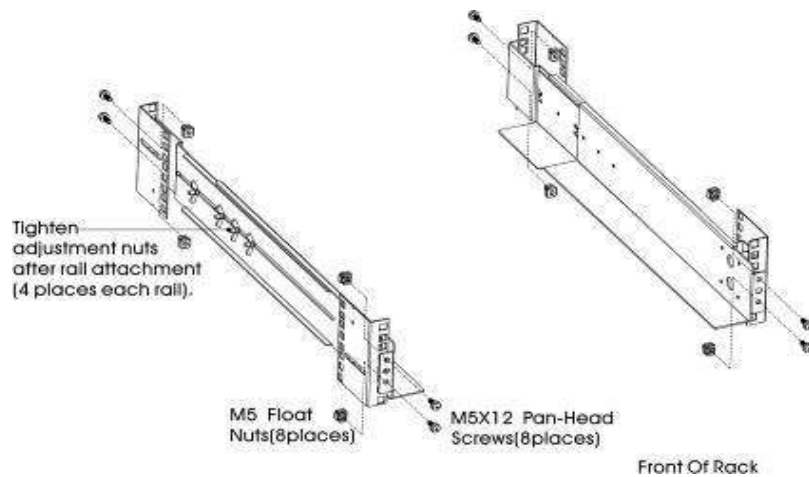

Figure2 Fixing the Rails

- e) Repeat Steps 3 and 4 for the other rail assembly.
- f) Tighten the four butterfly nuts in the middle of each rail assembly.
- g) If installing optional cabinets, repeat Step 1 through Step 6 for each rail kit.
- h) Place the UPS on a flat, stable surface with the front of the cabinet facing to you.
- i) Align the mounting brackets with the screw holes on each side of the UPS and fix with the supplied M4×8 flat-head screws(see Figure 3)

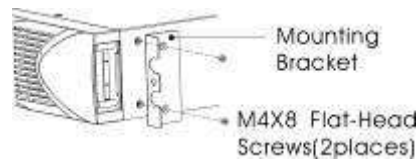

Figure3 Installing the Mounting Brackets

- j) If installing optional cabinets, repeat Step 8 and 9 for each cabinet.
- k) Slide the UPS and any other optional cabinets into the rack.
- l) Secure the front of the UPS to the rack using one M5×12 pan-head screws and one M5 cage nuts on each side(see Figure 4).Install the bottom screw on each side through the bottom hole of mounting bracket and the bottom hole of the rail.

Repeat for any optional cabinets.

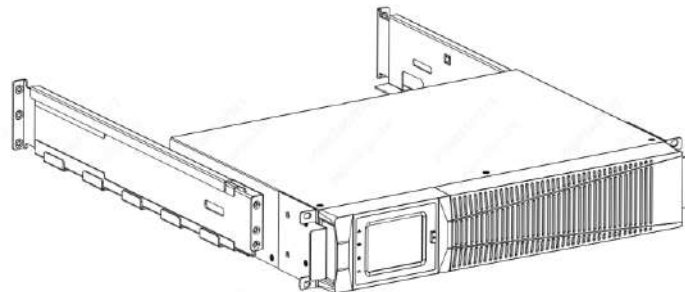

Figure 4 Securing the Front of the Cabinet

- m) Continue to the following section, "Rackmount Wiring Installation" .

(2)Rackmount Wiring Installation

- a) Installing the UPS, including connecting the UPS internal batteries
- b) Connecting any Optional EBP(S)

● To install the UPS

NOTE *Do not make unauthorized changes to the ups; otherwise, damage may occur to your equipment and void your warranty.*

NOTE *Do not connect the ups power cord to utility until after installation is completed.*

- a) If you are installing power management software, connect your computer to one of the communication ports or optional connectivity card. For the communication ports, use an appropriate cable.
- b) If your rack has conductors for grounding or bonding of ungrounded metal parts, connect the ground cable (not supplied) to the ground bonding screw. See “Rear Covers” for the location of the ground bonding screw for each model.
- c) If an emergency power-off (disconnect) switch is required by local codes, see “Remote Emergency Power-off” (REPO) to install the REPO switch before powering on the UPS.
- d) Continue to “UPS Startup” .

● **Connecting the EBP(s)**

CAUTION



Before connection, please keep the DC breakers to "OFF" position .A small amount of arcing may occur when connecting an EBP to the UPS. This is normal and will not harm personnel. Insert the EBP cable into the UPS battery connector quickly and firmly.

The battery pack supports parallel connection or single-unit operation, and the maximum number of parallel-connected units is 8.

The battery packs communicate with each other via CANBUS. Then, one of the battery packs is connected to the UPS using RS485, and the ID DIP switch of the battery connected to the UPS should be set to 0. Then set the DIP switches of the other batteries to 1 through 7, and connect them in sequence. Additionally, the ID DIP switches of each parallel-connected battery pack must be different.

The connection diagram is as follows:

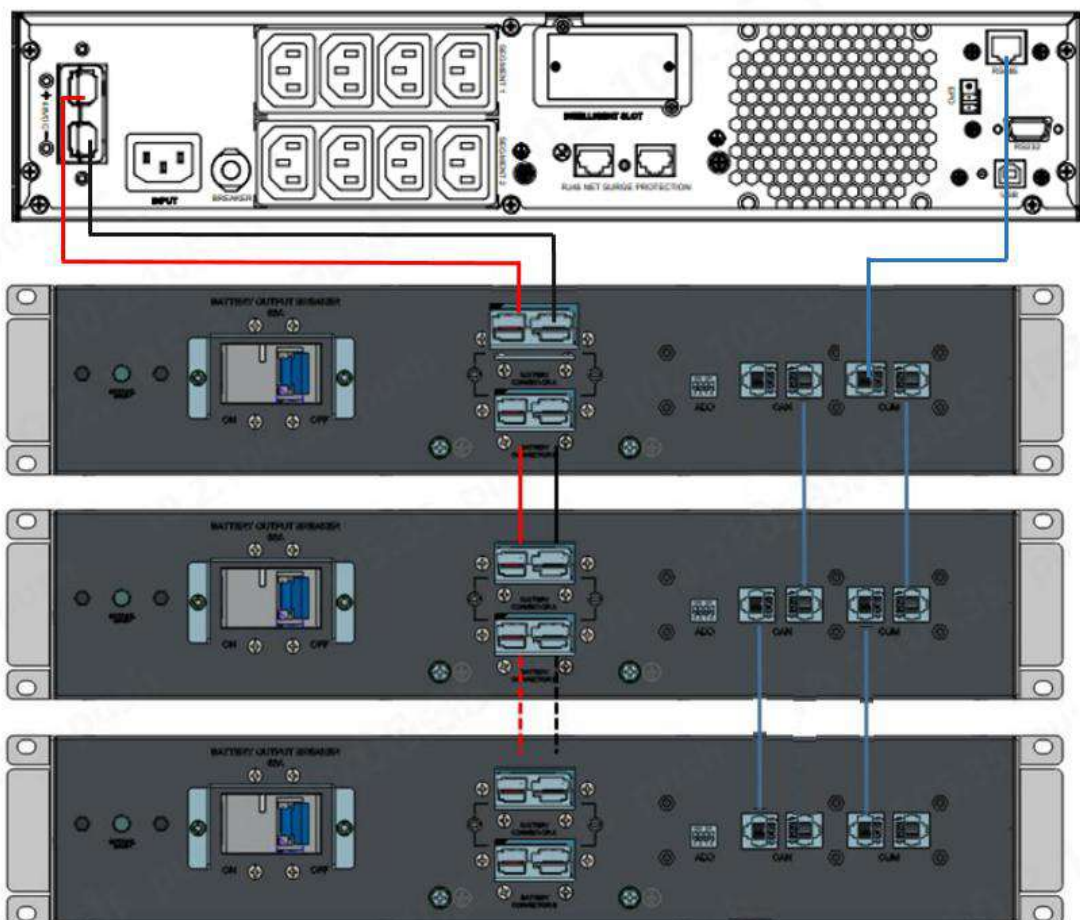

Figure 5 connection diagram

Please follow the steps below to start using the battery:

Step1: Make all the DC breaker in battery to OFF.

Step2: Connect all the batteries and UPS according to Figure 5 .

Step3:Set the DIP switch of the battery connected to the UPS to 0,then adjust the DIP switches of the other batteries to 1 to 7 in sequence without repetition.

Reference Picture	Num	DIP1	DIP2	DIP3	DIP4
	0	OFF	OFF	OFF	OFF
	1	OFF	OFF	OFF	ON
	2	OFF	OFF	ON	OFF
	3	OFF	OFF	ON	ON
	4	OFF	ON	OFF	OFF
	5	OFF	ON	OFF	ON
	6	OFF	ON	ON	OFF
	7	OFF	ON	ON	ON

Figure 6 ID Switch

Step4: Press all the DC breaker in battery to ON.

Step5: Press the Manual ON/OFF Switch and hold it until the battery's LEDs are on. Repeat this operation for each battery, make all the batteries with LEDs lit up.

Step6: Check if there is any battery with Alarm LED on or blinking. If so, read the fault information via the LCD alarm code of UPS , and handle the corresponding alarms using the information in the table under 3-6, item b. If all batteries are with Run LED on, they are ready to be used

● Battery power off

Press the button Manual ON/OFF Switch for more than 3 seconds then release, the battery will enter shutdownmode. And all the LEDs will turn off.

Note: If a battery needs to be replaced and disconnected with UPS, please press the DC breaker to OFF first

● Rackmount converted to Tower Installation

(1) Rackmount converted to Tower plasticbase installation

① Two plastic base brackets

② Flatten it after intercrossing
 Intercross as following Figure:

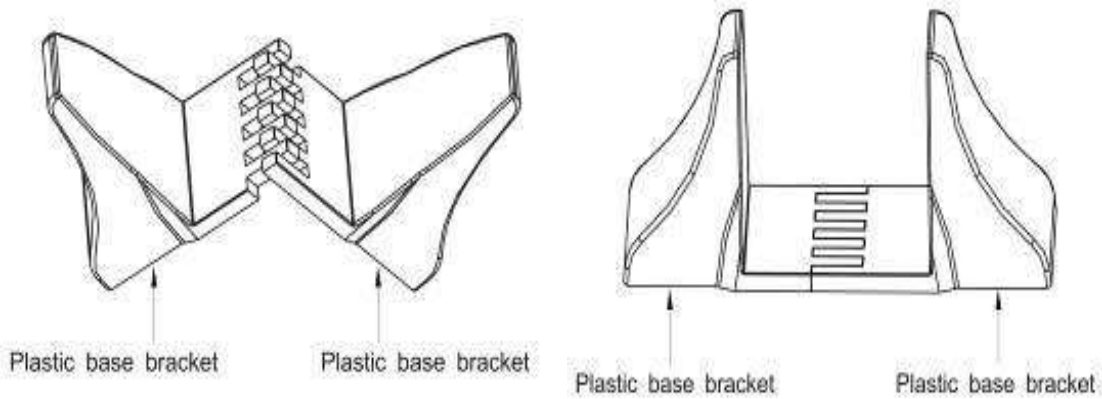
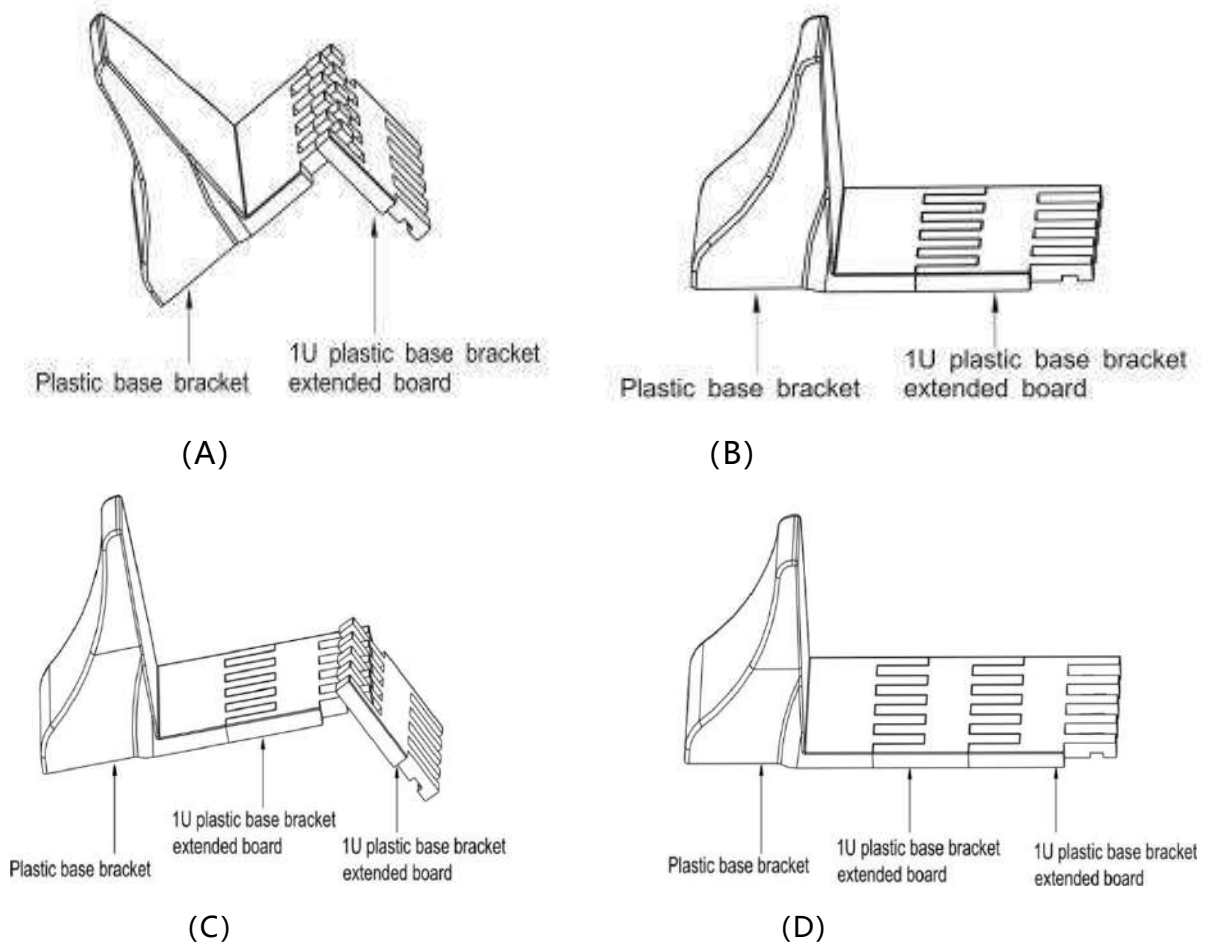

Figure 7 plastic base installation

③ If an EBP is needed to be placed in the middle, the assembly of plastic base is similar(Figure 11).The difference is that two 1U plastic base extended boards are added in the middle.(as the following shows)



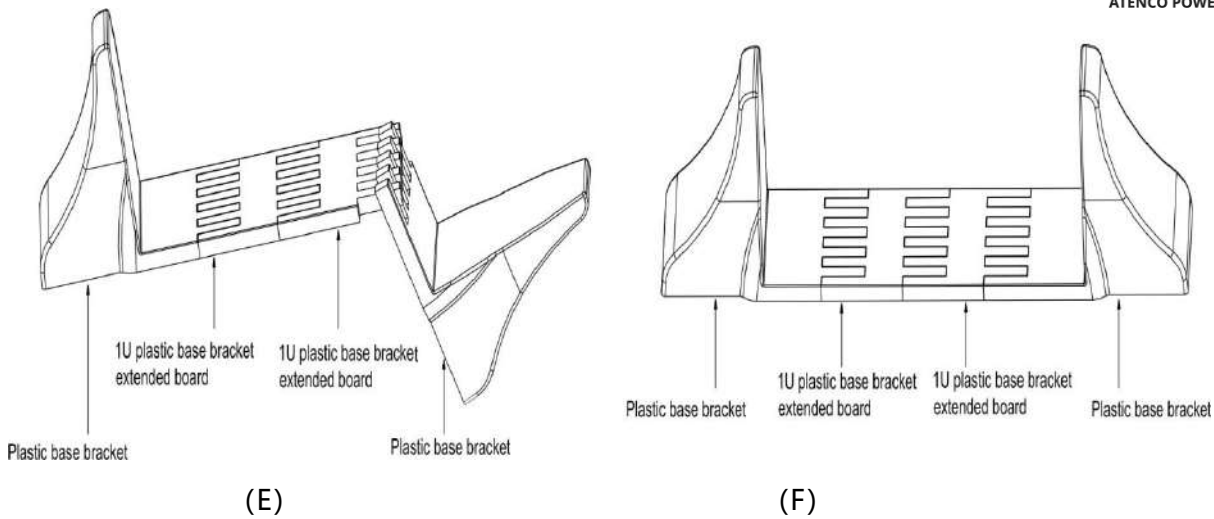

Figure 8 increase EBP plasticbase installation

(2) Rack mount converted to Tower LCD Display plastic base installation

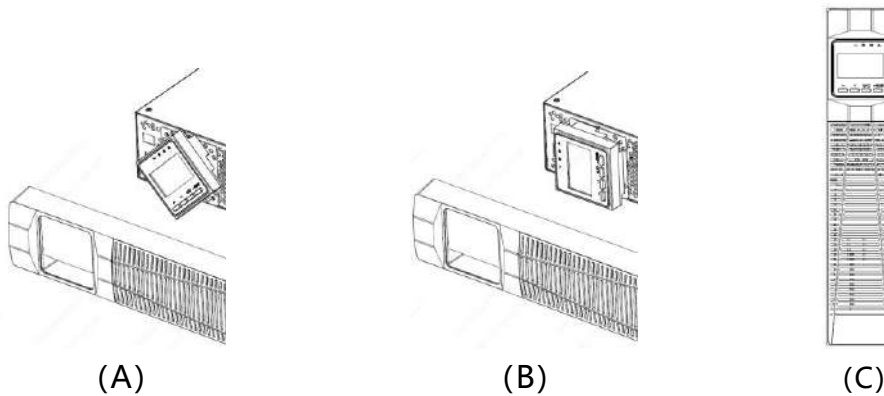

Figure 9 increase UPS plasticbase installation

2-4 UPS startup and turn off

● Startup operation

(1) Turn on the UPS in line mode

NOTE Verify that the total equipment ratings do not exceed the UPS capacity to prevent an overload alarm.

- Once mains power is plugged in, the UPS will charge the battery, the UPS is standby status.
- Press and hold the ON key for more than three seconds to start the UPS, then it will start the inverter.
- Once started, the UPS will perform a self-test function, LED will light and go out circularly and orderly. When the self-test finishes, it will come to line mode, the corresponding LED lights, the UPS is working in line mode.

(2) Turn on the UPS by DC without mains power

- a) When mains power is disconnected, press and hold the ON key for more than half a second to start UPS.
- b) The operation of the UPS in the process of start is almost the same as that when mains power is in. After finishing the self-test, the corresponding LED lights and the UPS is working in battery mode.

● Turn off operation

(1) Turn off the UPS in line mode

- a) Press and hold the OFF key for more than half a second to turn off the UPS and inverter.
- b) After the UPS shutdown, the LEDs go out and there is no output. If output is needed, you can set bps "ON" on the LCD setting menu.

(2) Turn off the UPS by DC without mains power

- a) Press and hold the OFF key for more than half a second to turn off the UPS.
- b) When turning off the UPS, it will do self-testing firstly. The LEDs light and go out circularly and orderly until there is no display on the cover.

2-5 Set battery quantity

When performing the initial installation or modifying the number of Batteries, the correct quantity must be configured on the UPS setting interface.

- a) After the UPS turn ON, press buttons "UP+Down" for 5 seconds and then goes into the setting interface page.
- b) Press the UP or DOWN buttons to select the BATT NUM Setting Page.
- c) press the ENTER/ON button to access the setting item,
- d) Adjust the number of the batteries with the UP and DOWN buttons

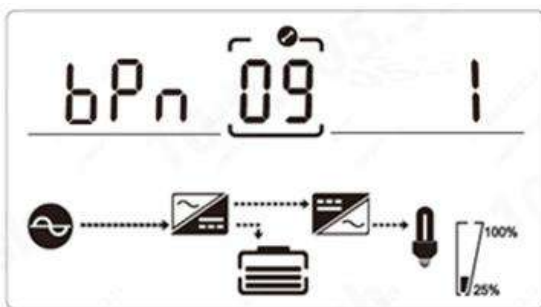

Figure 10 Battery Quantity setup page

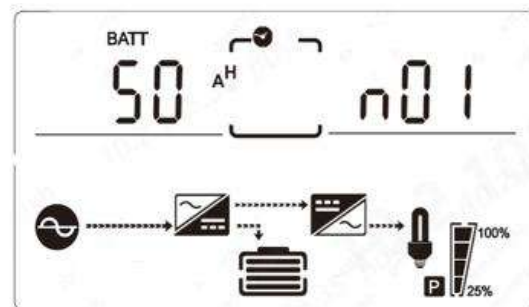

figure 11 Display Battery Quantity page

- e) Press the ENTER button to confirm the setting
- f) Press ESC/OFF to exit the setting page.
- g) Turn off the UPS in battery mode, and the settings will be saved successfully once the LCD display turns off automatically.

2-6 Operation and Display Panel

The operation and display panel, shown in below chart, is on the front panel of the UPS. It includes three indicators, four function keys and a LCD display, indicating the operating



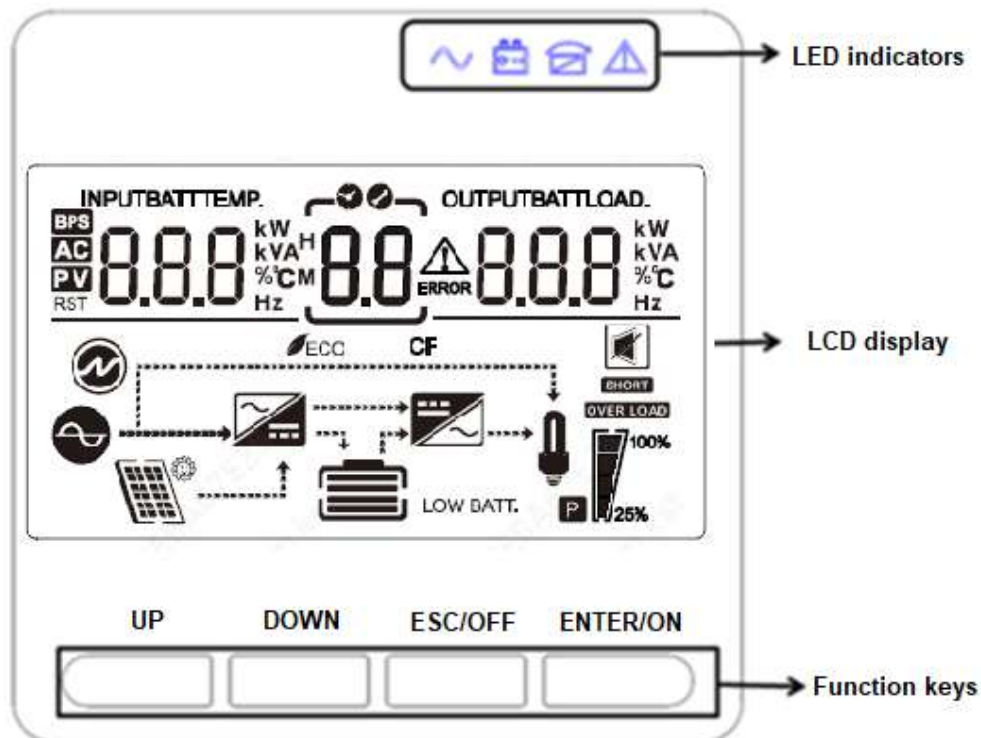

status and input/output power information.

LCD control panel introduction



- (1) LED (from right to left: "alarm" , "bypass" , "battery" , "inverter");
- (2) On-Line UPS LCD display; (3) Function keys

LED Indicator

Indicator	Status	Description
 Red	On	The UPS has an active alarm or fault.
 Yellow	On	The UPS is in Bypass mode. The UPS is operating normally on bypass during High Efficiency operation.
 Yellow	On	The UPS is in Battery mode.
 Green	On	The UPS inverter is operating normally on Online mode & Battery mode

NOTE When power on or startup , these indicators will turn on and off sequentially.

NOTE On different operation models , these indicators will indicate differently.



Function Keys

Function Key	Description
ESC/OFF	To turn off the ups or exit setting mode without save.
UP	To go to previous selection.
Down	To go to next selection.
ENTER/ON	To turn on the ups or confirm the selection in setting mode or enter setting mode.

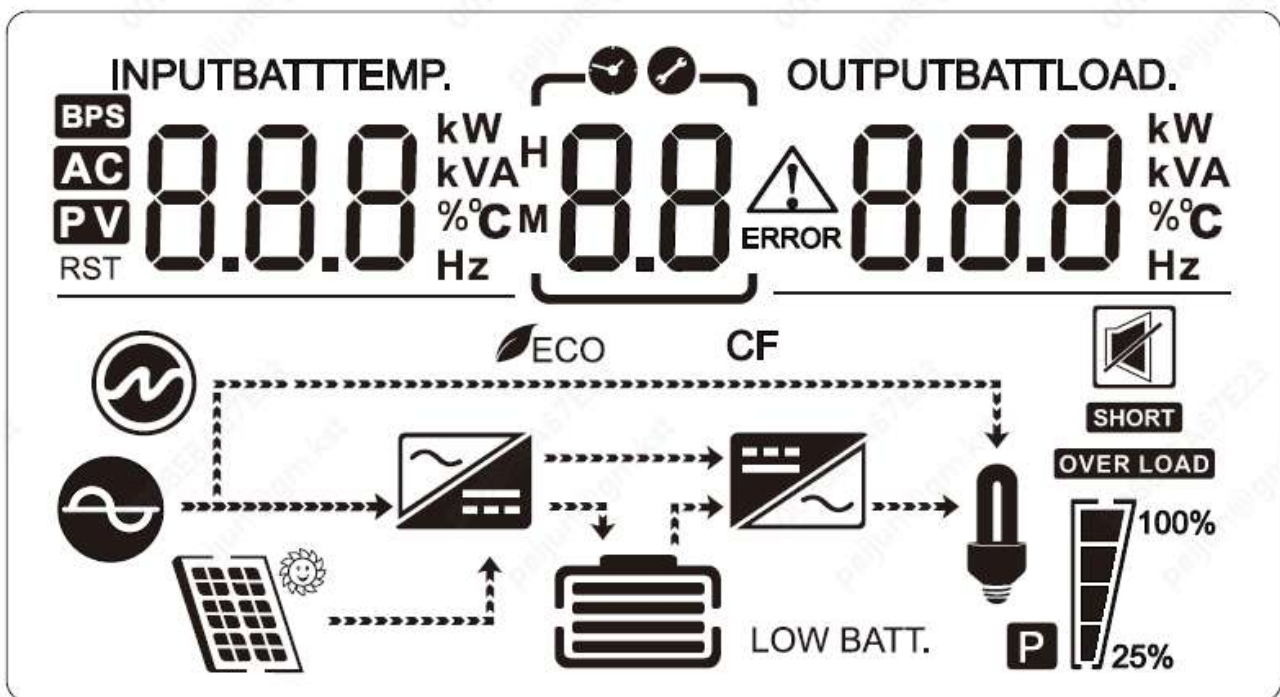
LCD Display Icons



Icon	Function description
Input Source Information	
AC	Indicates the AC input.
INPUTBATTTEMP. 8.8.8 kW VAh °C Hz%	Indicate input voltage, input frequency, battery voltage and Temp
Configuration Program and Fault Information	
	Indicates the setting programs.

	<p>Indicates the warning and fault codes.</p> <p>Warning:  flashing with warning code.</p> <p>Fault:  lighting with fault code</p>
---	--

Output Information

<p>OUTPUTBATTLOAD.</p> 	<p>Indicate output voltage, output frequency, load percent, load in VA, load in Watt and discharging current.</p>
--	---







Battery Information

	<p>Indicates battery level by 0-24%, 25-49%, 50-74% and 75-100% in battery mode and charging status in line mode.</p>
---	---



In AC mode, it will present battery charging status.





Status	Battery capacity	LCD Display
Constant Current mode	0-24%	4 bars will flash in turns
	25-49%	Bottom bar will be on and the other three bars will flash in turns
	50-74%	Bottom two bar will be on and the other two bars will flash in turns
	75-100%	Bottom three bar will be on and the top bars will flash

Load Information

	<p>Indicates overload.</p>			
	<p>Indicates the load level by 0-24%, 25-50%, 50-74% and 75-100%.</p>			
	0%~25%	25%~50%	50%~75%	75%~100%
				

Mode Operation Information

	<p>Indicates unit connects to the mains.</p>
	<p>Indicates load is supplied by utility power.</p>

	Indicates the utility charger circuit is working.
	Indicates the DC/AC inverter circuit is working.
CF	Indicates the UPS is working converter frequency mode.
GEN	Indicates the UPS is working Generator mode.
	Indicates the UPS is working ECO mode.
Alarm Information	
	Indicates unit alarm buzzer is disabled.
	Indicates unit overload alarm.
LOW BATT.	Indicates unit battery low status.
SHORT	Indicates unit output short circuit.

3. Operations

3-1 Button operation

Button	Function
ON /ENTER Button	<ul style="list-style-type: none"> ➤ Turn on the UPS: Press and hold ON button for at least 2 seconds to turn on the UPS. ➤ Confirm current settings: When the UPS enters the setting mode, must press this button to confirm the settings value what you want, next press up/down button to change settings information ➤ Out of bypass mode: when the UPS enter to bypass mode, press and hold this button it will switch to normal mode.
OFF/ESC Button	<ul style="list-style-type: none"> ➤ Turn off the UPS: Press and hold this button at least 2 seconds to turn off the UPS in battery mode. UPS will be in standby mode under power normal or transfer to Bypass mode if the Bypass enable setting by pressing this button. ➤ Exit setting mode: Press this button to exit setting mode when in UPS setting mode, but save nothing.
UP Button	<ul style="list-style-type: none"> ➤ Up key: Press this button to display previous selection in UPS setting mode.
DOWN Button	<ul style="list-style-type: none"> ➤ Down key: Press this button to display next selection in UPS setting mode. ➤ To confirm selection and exit setting mode: Press this button to confirm selection and exit setting mode when LCD display the last selection in UPS setting mode.
UP + DOWN Button	<ul style="list-style-type: none"> ➤ Setting mode: Press and hold this button for 5 seconds to enter UPS setting mode.

3-2 Setup the UPS

Step 1: UPS input connection

Plug the UPS into a two-pole, three-wire, grounded receptacle only. Avoid using extension cords.

- For 100/110/115/120/125VAC models: The power cord is supplied in the UPS package.

Step 2: UPS output connection

- For socket-type outputs, simply connect devices to the outlets.
- For terminal-type input or outputs, please follow below steps for the wiring configuration:
 - a) Remove the small cover of the terminal block
 - b) Suggest using AWG10 power cords for 3KVA model
 - c) Upon completion of the wiring configuration, please check whether the wires are securely affixed.
 - d) Put the small cover back to the rear panel.

Step 3: Communication connection

Communication port:

USB port



RS-232 port

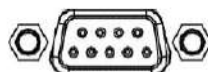

Intelligent slot



To allow for unattended UPS shutdown/start-up and status monitoring, connect the communication cable one end to the USB/RS-232 port and the other to the communication port of your PC. With the monitoring software installed, you can schedule UPS shutdown/start-up and monitor UPS status through PC.

The UPS is equipped with intelligent slot perfect for either SNMP or Relay card. When installing either SNMP or Relay card in the UPS, it will provide advanced communication and monitoring options.

NOTE: USB port and RS-232 port can't work at the same time.

Step 4: Turn on the UPS

Press the ON button on the front panel for two seconds to power on the UPS.

Note: The battery charges fully during the first five hours of normal operation. Do not expect full battery run capability during this initial charge period.

Step 5: Install software

Find the download link on the software installation guide in the packaging box, download the corresponding software package then install.

3-3 LCD display

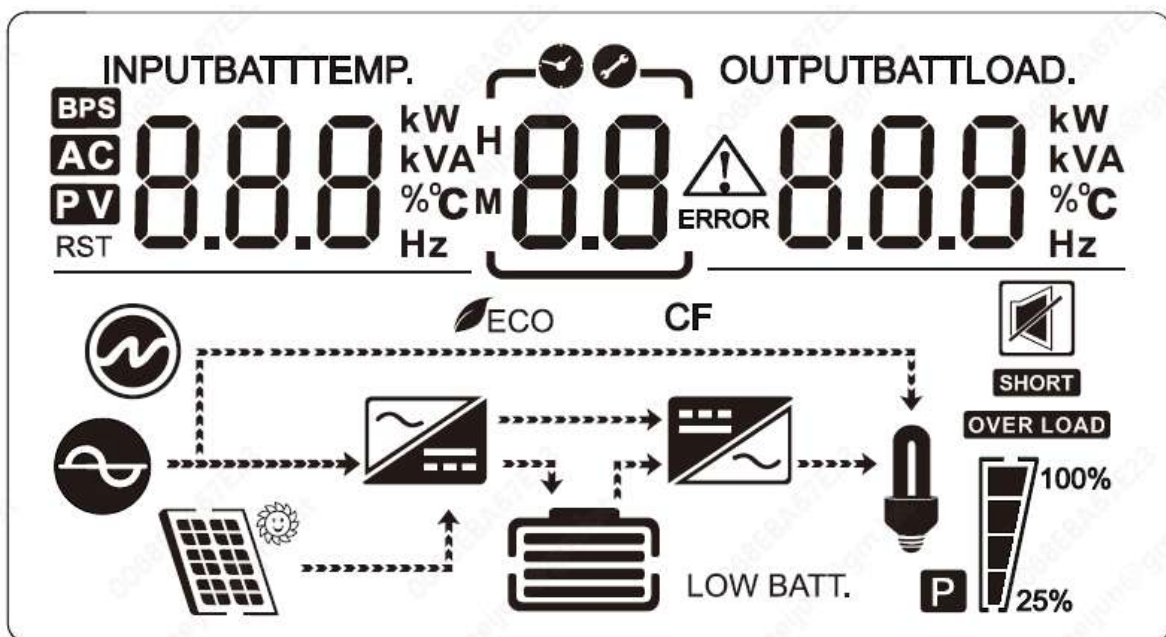

Part one: Rack display



All the icons and graphic of the interface would lit on one time during UPS power up.

There are 8 interfaces available in the LCD display.

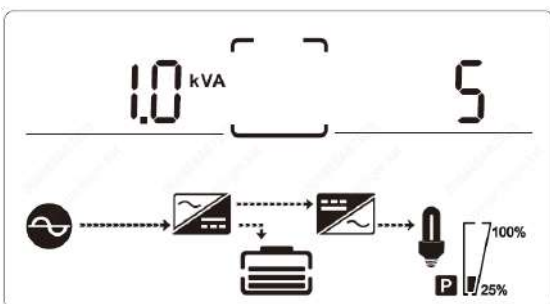
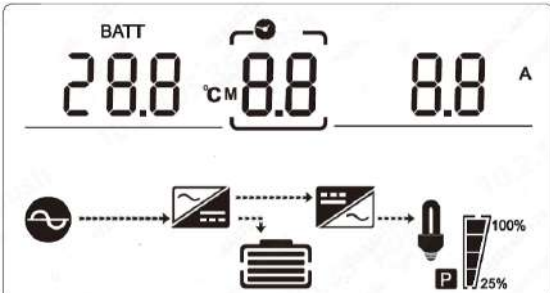
Item	Interface Description	Content Displayed
01	Input voltage& Output voltage	<p>INPUT 120 V OUTPUT 120 V</p>
02	Input frequency& Output frequency	<p>INPUT 60.0 Hz OUTPUT 59.9 Hz</p>
03	Battery voltage& Battery capacity	<p>BATT 38.3 V H 3.5 99 %</p>
04	Environment Temperature	<p>TEMP. 28 °C</p>
05	Load	<p>LOAD. 1.8 kW 1.9 kVA</p>

06	Firmware Version	 <p>The LCD display shows 'UEA' on the left and '920' on the right. Below the display is a system diagram showing AC input, a battery, and a load with a 100%/25% indicator.</p>
07	UPS model.	 <p>The LCD display shows '1.0 kVA' on the left and '5' on the right. Below the display is a system diagram showing AC input, a battery, and a load with a 100%/25% indicator.</p>
08	Battery temperature Charging current	 <p>The LCD display shows 'BATT' above '28.8 °C' on the left and '8.8 A' on the right. Below the display is a system diagram showing AC input, a battery, and a load with a 100%/25% indicator.</p>
09	Total battery capacity(Ah) Battery number	 <p>The LCD display shows 'BATT' above '50 AH' on the left and 'n01' on the right. Below the display is a system diagram showing AC input, a battery, and a load with a 100%/25% indicator.</p>
10	Alarm Code(Warning Message) All alarm codes are present when abnormal behavior(s) occur(s)	 <p>The LCD display shows 'UEA' on the left, '19 ERROR' in the middle, and '040' on the right. Below the display is a system diagram showing AC input, a battery, and a load with a 100%/25% indicator.</p>

3-4 UPS setting

The UPS has setting functions. This user settings can be done under any kind of UPS working mode. The setting will take effect under certain condition. Below table describes how to set the UPS.

The setting function is controlled by 4 buttons (Up ,Down, ON/Enter,OFF/ESC):

“Up ▲ + Down ▼” ---goes into the setting page;

ON/Enter --- - confirm the settings option;

Up ▲ &Down ▼--- value adjustment for choosing different pages;



OFF/ESC--- Exit setting mode;

After the UPS turn ON, press buttons “UP+Down” for 5 seconds and then goes into the setting interface page.

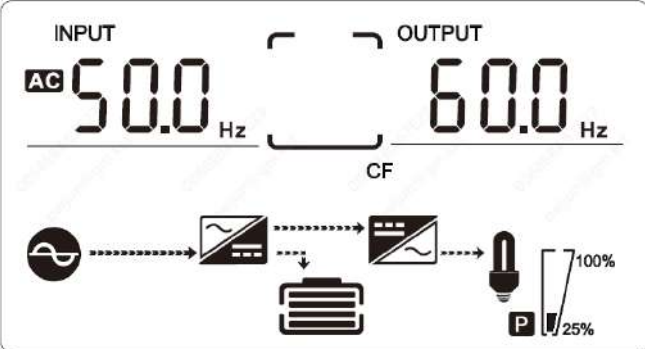
Note: Press “Down” button to confirm selection and exit setting mode when LCD display the last selection in UPS setting mode.

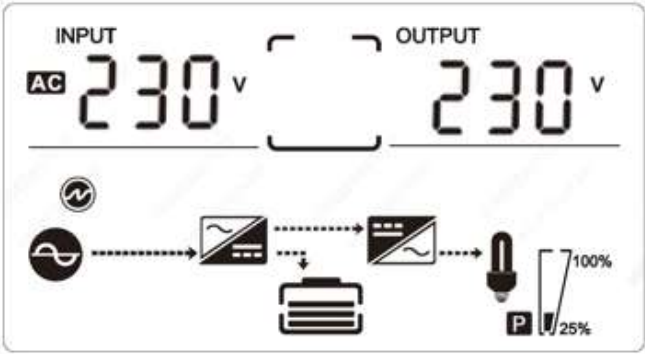
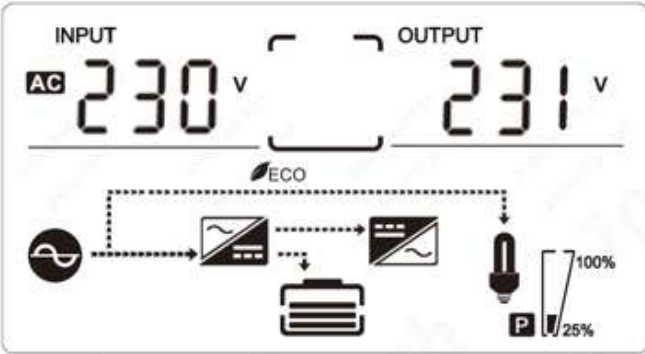
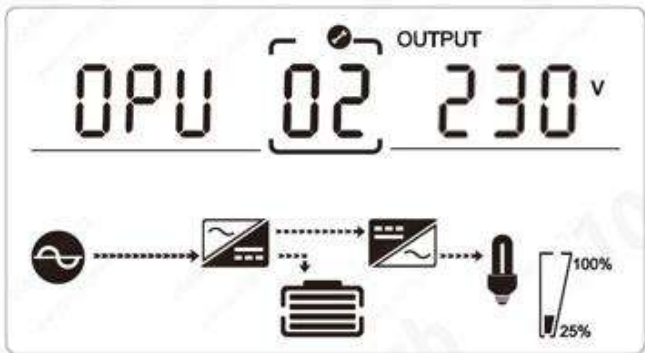
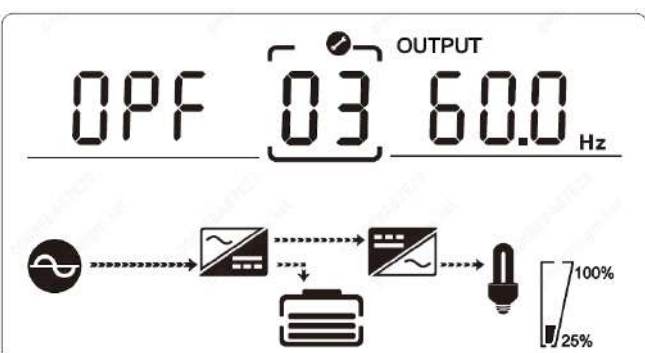
Item	Settings	Content display
01	<p style="text-align: center;">Mode setting</p> <p>Press Enter button to change the setting (NOR or CF or GEN or ECO). Press UP button ▲ to select the previous setting. Press DOWN button ▼ to select the next setting.</p>	
	<p style="text-align: center;">CF mode</p>	

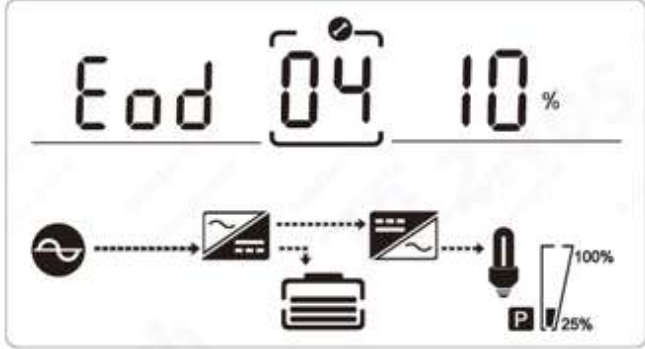
	<p>GEN mode</p>	
	<p>ECO mode</p>	
<p>02</p>	<p>Output voltage setting</p> <p>Press Enter button to change the setting(220,230,240). Press UP button ▲ to select the previous setting. Press DOWN button ▼ to select the next setting.</p>	
<p>03</p>	<p>Frequency setting</p> <p>Press Enter button to change the setting (50 or 60Hz). Press UP button▲ to select the previous setting. Press DOWN button ▼ to select the next setting.</p>	

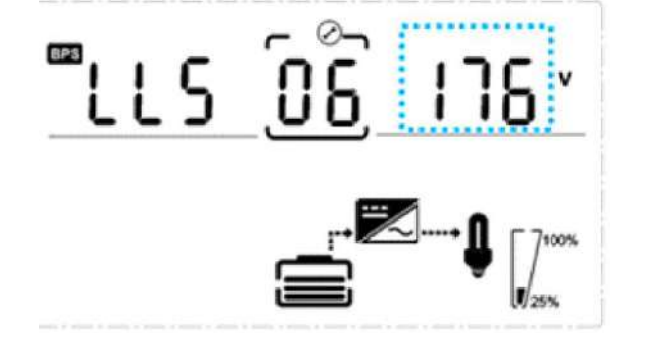
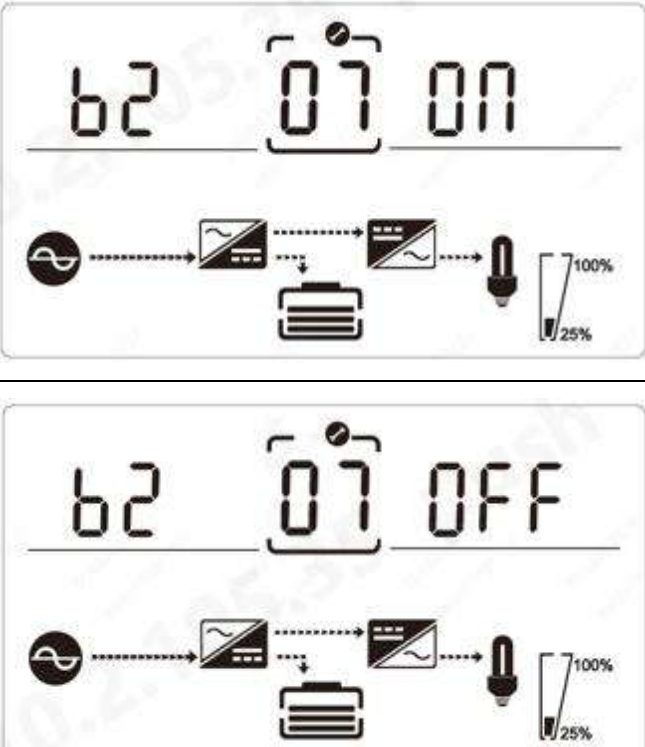
<p>04</p>	<p>Battery EOD voltae setting(SEFMENT 1) Press Enter button to change the setting (0%10%/20%/30%). Press UP button ▲ to select the previous setting. Press DOWN button ▼ to select the next setting.</p>	
<p>05</p>	<p>Bypass voltage upper limit setting Press Enter button to change the setting(The bypass voltage upper limit range is 230-264Vac). Press UP button ▲ to select the previous setting. Press DOWN button ▼ to select the next setting.</p>	
<p>06</p>	<p>Bypass voltage lower limit setting Press Enter button to change the setting(The bypass voltage lower limit range is 176-220Vac). Press UP button ▲ to select the previous setting. Press DOWN button ▼ to select the next setting.</p>	
<p>07</p>	<p style="text-align: center;">Mute setting</p> <p>Press Enter button to change the setting(ON or OFF). Press UP button ▲ to select the previous setting. Press DOWN button ▼ to save and exit the setup.</p> <p style="text-align: center;">Mute OFF</p> <p>When it is off status , any alarm activity ,the UPS buzzer would not be able to beep to inform the user.</p>	

8	<p>BYPASS enable/disable setting</p> <p>Press Enter button to change the setting(ON or OFF). Press UP button ▲ to select the previous setting. Press DOWN button ▼ to save and exit the setup.</p>	
	<p>Bypass disable setting</p>	
9	<p>Battery Count Setting</p> <p>Set the number of battery packs (1 to 8) to match the actual connected battery packs.</p>	

3-5 Operational Status and Mode(s)

item	Content Displayed
2	Standby Mode
3	No Output
4	Bypass Mode
5	Utility Mode
6	Battery Mode
7	Battery Self-diagnostics
8	Inverter is starting up
9	ECO Mode
10	EPO Mode
11	Maintenance Bypass Mode
12	Fault Mode
13	Generator Mode

3-6 Alarm or Fault reference code

a) Alarms related to the UPS itself:

Event log	UPS Alarm Warning	Buzzer	LED
2	Inverter fault(Including Inverter bridge is shorted)	Beep continuously	Fault LED lit
9	Fan fault	Beep continuously	Fault LED lit
12	Initial fault	Beep continuously	Fault LED lit
13	Battery Charger fault	Beep continuously	Fault LED lit
15	DC Bus over voltage	Beep continuously	Fault LED lit
16	DC Bus below voltage	Beep continuously	Fault LED lit
17	DC bus unbalance	Beep continuously	Fault LED lit
18	Soft start failed	Beep continuously	Fault LED lit
19	UPS Inside Over Temperature	Twice per second	Fault LED lit
20	Heatsink Over Temperature	Twice per second	Fault LED lit
26	Battery over voltage	Once per second	Fault LED blinking
27	Input voltage reversed	Twice per second	Fault LED blinking
28	Bypass voltage reversed	Twice per second	Fault LED blinking
29	Output Short-circuit	Once per second	Fault LED blinking
30	Input current limit	Once per second	Fault LED blinking
31	Bypass over current	Once per second	BPS LED blinking
32	Overload	Once per second	INV or BPS LED blinking
33	No battery	Once per second	Battery LED blinking
34	Battery under voltage	Once per second	Battery LED blinking
35	Battery low pre-warning	Once per second	Battery LED blinking
36	Over load time out	Once per 2 seconds	Fault LED blinking
37	DC component over limit.	Once per 2 seconds	INV LED blinking
39	Mains volt. Abnormal	Once per 2 seconds	Battery LED lit
40	Mains freq. abnormal	Once per 2 seconds	Battery LED lit
41	Bypass Not Available	Twice per second	BPS LED blinking
42	Bypass unable to trace	Twice per second	BPS LED blinking
45	EPO Activated	Twice per second	BPS LED blinking

b) UPS alarms related to battery packs:

Alarm code	Alarm info	Customer Action
50	BMS communication is lost.	Check communication cable connection, check DIP switch, reboot the battery pack.
51	BMS protection	(BMS protection triggered, battery charging and discharging are disabled) Refer to detailed protection code.
52	BMS alarm	(BMS alarm triggered, battery can run normally) Refer to detailed alarm code.

53	Firmware version inconsistent	Update to the same firmware and avoid using different firmware.
54	Error in the setting of the number of battery packs	Check if battery pack number and setting number match, check battery cable connection.
55	Present signal loss	Check if the communication cable between UPS and first battery pack is damaged.
57	Cell Overvoltage	Discharge or stand still, battery pack can recover by itself.
58	Cell Low Voltage	Charge the battery, it'll recover by itself
59	Charging Overtemperature	Battery will recover by itself after temperature drop down.
60	Charging Low Temperature	Battery will recover by itself after temperature rise up.
61	Charging Over Current	Reboot the battery pack
62	Discharging Over Current	Reboot the battery pack
64	Mosfet Overtemperature	Battery will recover by itself after temperature drop down.
65	Discharging Overtemperature	Battery will recover by itself after temperature drop down.
66	Discharging Low Temperature	Battery will recover by itself after temperature rise up.
70	Safety Low Voltage Protection	It cannot recover by itself. Need to provide data to manufacturer to confirm the issue.
71	Relay Failure	It cannot recover by itself. Need to provide data to manufacturer to confirm the issue.
72	Battery address conflict	Check if the DIP switch is correct
74	Discharging Overtemperature Critical	Check the ambient temperature, battery will recover by itself after temperature drop down.
75	Discharging Low Temperature Critical	Battery will recover by itself after temperature rise up.
76	Cell Overvoltage Critical	No action is needed, battery will recover by itself
77	Cell Low Voltage Critical	Charge the battery
78	Charging Overtemperature Critical	Check the ambient temperature, battery will recover by itself after temperature drop down.
79	Charging Low Temperature Critical	Battery will recover by itself after temperature rise up.
80	Charging Over Current Critical	Reboot the battery pack
81	Discharging Over Current Critical	Reboot the battery pack
82	Internal Communication Fault Critical	If it can not recover after reboot, provide data to manufacturer to confirm the issue.
83	Internal Communication Alarm	If it can not recover after reboot, provide data to manufacturer to confirm the issue.
84	Mosfet Overtemperature	Check the ambient temperature, battery will recover by itself after temperature drop down.

85	Permanent fail	If it can not recover after reboot, provide data to manufacturer to confirm the issue.
86	Charging Over Current overflow	If it can not recover after reboot, provide data to manufacturer to confirm the issue.
87	Discharging Over Current overflow	If it can not recover after reboot, provide data to manufacturer to confirm the issue.
88	Second OVP	BMS is damaged, provide data to manufacturer to confirm the issue.
89	Fuse damage	BMS is damaged, provide data to manufacturer to confirm the issue.
90	Analog front-end protection	If it can not recover after reboot, provide data to manufacturer to confirm the issue.
91	Hardware Circuit Protection	If it can not recover after reboot, provide data to manufacturer to confirm the issue.

4. Trouble shooting

If the UPS system does not operate correctly, please solve the problem by using the table below and the Trouble Shooting Chart.

Symptom	Possible cause	Remedy
No indication and alarm even though the mains is normal.	The AC input power is not connected well.	Check if input power cord firmly connected to the mains.
	The AC input is connected to the UPS output.	Plug AC input power cord to AC input correctly.
Alarm code is shown as “33” and battery led blinking.	The external or internal battery is incorrectly connected.	Check if all batteries are connected well.
Alarm code is shown as “26” and battery led blinking.	Battery voltage is too high or the charger is fault.	Contact your dealer.
Alarm code is shown as “27&28” and FAULT led light.	Mains Input reverse & Bypass Input reverse	Check input L/N wiring Reverse connection
Alarm code is shown as “34” and battery led blinking	Battery voltage is too low or the charger is fault.	Contact your dealer.
Alarm code is shown as “32” and INV or BYPASS led blinking.	UPS is overload	Remove excess loads from UPS output.

Alarm code is shown as "29" and FAULT led light.	The UPS shut down automatically because short circuit occurs on the UPS output.	Check output wiring and if connected devices are in short circuit status.
Alarm code is shown as "9" and FAULT led light.	Fan fault.	Contact your dealer.
Alarm code is shown as "01,02,15,16,17,18"	A UPS internal fault has occurred.	Contact your dealer.
Battery backup time is shorter than nominal value	Batteries are not fully charged	Charge the batteries for at least 5 hours and then check capacity. If the problem still persists, consult your dealer.
	Batteries defect	Contact your dealer to replace the battery.
Alarm code is shown as "50"	Batteries communication is lost	Check communication cable connection, check DIP switch, reboot the battery pack.
Alarm code is shown as "54"	Error in the setting of the number of battery packs	Check if battery pack number and setting number match, check battery cable connection.
Alarm code is shown as "51"	Batteries protection	(BMS protection triggered, battery charging and discharging are disabled) Refer to detailed protection code in 3-6(b).
Alarm code is shown as "52"	Batteries alarm	(BMS alarm triggered, battery can run normally) Refer to the detailed alarm code in 3-6(b)

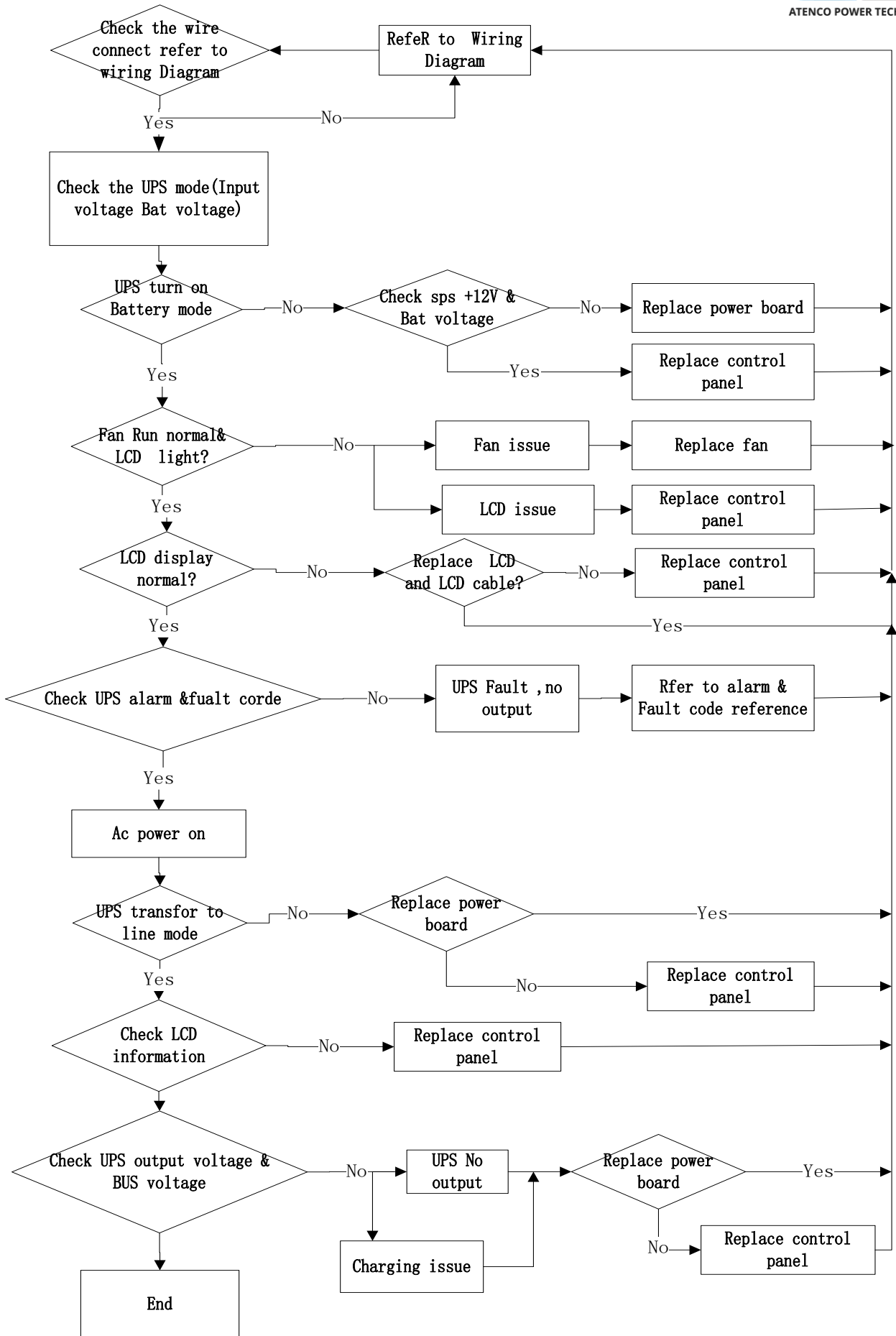

Trouble Shooting Chart

5. Storage and Maintenance

● Operation

The UPS system contains no user-serviceable parts. If the battery service life (3~5 years at 25°C ambient temperature) has been exceeded, the batteries must be replaced. In this case, please contact your dealer.

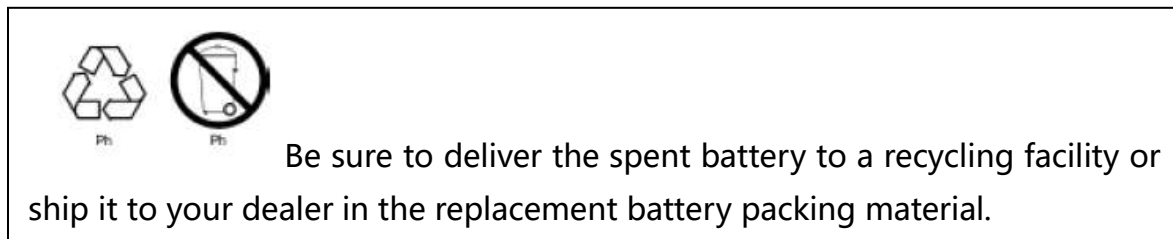
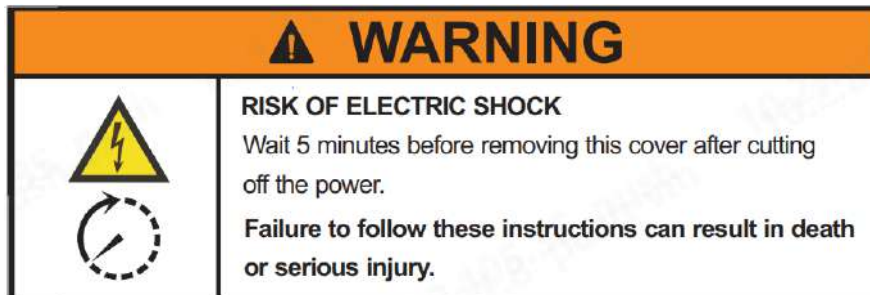

● Storage

Before storing, charge the UPS 5 hours. Store the UPS covered and upright in a cool, dry location. During storage, recharge the battery in accordance with the following table:

Storage Temperature	Recharge Frequency	Charging Duration
-25°C - 40°C	Every 3 months	1-2 hours
40°C - 45°C	Every 2 months	1-2 hours

6. Options

SNMP card:internal SNMP

- ◆ Loosen the 2 torquescrews (on each side of the card).
- ◆ Carefully insert the SNMP card and lock the screws

The slot called SNMP supports the MEGA protocol. We advise that NetAgentII-3 ports is also a tool to remotely monitor and manage any UPS system.

NetAgentII-3 Ports supports the Modem Dial-in(PPP) function to enable the remote control via the internet when the network is unavailable.

In addition to the features of a standard NetAgent Mini, NetAgentII has the option to add NetFeelerLite to detect temperature, humidity, smoke and security sensors. Thus, making NetAgentII a versatile management tool. NetAgentII also supports multiple languages and is setup for web-based auto language detection.

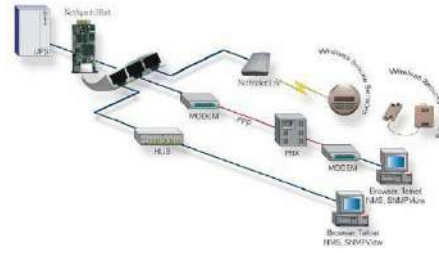

Typical topology of the UPS Network Management

Relay card

Mini dry contact card is used for providing the interface for UPS peripheral monitoring. The contact signals can reflect UPS running status. The card is connected to peripheral monitoring devices via terminal board to facilitate the effective monitoring of the real-time status of UPS and timely feedback the status to monitor when abnormal situation occurs (such as UPS failure, mains interruption, UPS bypass and ect.). It is installed in the intelligent slot of the UPS.

The relay card includes 6 output ports and one input port. Please refer to the following table for detail.



Product appearance



Pins definition of connecting terminal on the board

Terminal No.	Terminal function	Terminal No.	Terminal function
1	Common source	9	Bypass active NO
2	UPS on NO	10	Bypass active NC
3	AC fail NO	11	UPS fail NO
4	AC fail NC	12	UPS fail NC
5	Batt low NO	CN4-1	Remote shutdown
6	Batt low NC	CN4-2	GND
7	UPS alarm NO		
8	UPS alarm NC		

Relay card electrical parameter

	max	Type
Relay card contact	(Max Switched Voltage) AC:120V DC:24V	AC:120V
		DC:5~12V
	(Max Switched Current) AC:1A DC:1A	AC:1A
		DC:1A

Emergency Power-off (EPO)

EPO is used to shut down the UPS from a distance. This feature can be used for shutting down the load and the UPS by thermal relay, for instance in the event of room overtemperature. When EPO is activated, the UPS shuts down the output and all its power converters immediately. The UPS remains on to alarm the fault.

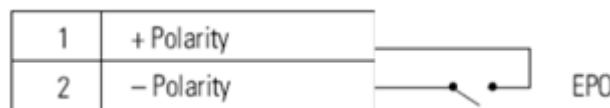

EPO Connections

NOTE Depending on user configuration, the pins must be shorted or opened to keep the UPS running. To restart the UPS, reconnect (re-open) the EPO connector pins and turn on the UPS manually. Maximum resistance in the shorted loop is 10 ohms. Always test the EPO function before applying your critical load to avoid accidental load loss. Leave the EPO connector installed onto the EPO port of the UPS even if the EPO function is not needed.

Load GROUPS

Load groups are sets of receptacles that can be controlled by power management software or through the display, providing an orderly shutdown and startup of your equipment. For example, during a power outage, you can keep critical equipment running while you turn off other equipment. This feature allows you to save battery power. Each UPS has two load groups:

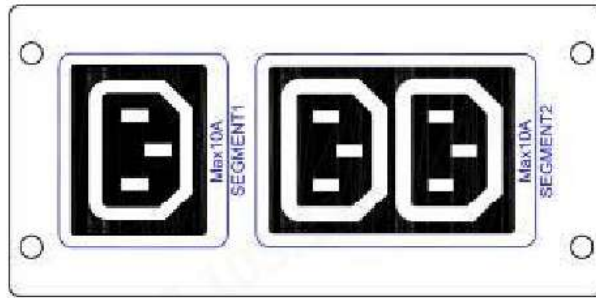

SEGMENT OUTPUTS 1: The power shedding battery voltage of this group can be set by LCD. (0%,10%, 20%, 30% optional).

SEGMENT OUTPUTS 2: The power shedding battery end of discharge(EOD).

7. Specification

MODEL	RM11E-1k-PRO-L-LI	RM11E-2k-PRO-L-LI	RM11E-3k-PRO-L-LI
General			
Capacity (VA/Watts)	1000VA/1000W	2000VA/2000W	3000VA/3000W
Product Size WxDxH (mm)	440*460*86.5mm	440*500*86.5mm	440*500*86.5mm
Net Weight(kg)	8.1	10.1	10.7
Input Characteristics			
Input voltage nominal	220Vac,230Vac(Default), 240Vac		
Input voltage range	176-264Vac@full load; 110-300Vac@50% load		
Input Frequency Range	40-70Hz		
Input Power Factor	>0.98 (full load)	>0.99 (full load)	
Input Connection Cord	C14	C20	
Output Characteristics			
Output voltage (Phase Voltage)	220Vac,230Vac(Default), 240Vac		
On Line Efficiency (up to)	90.00%	92.00%	92.00%
Economy mode efficiency	95.00%	96.00%	96.50%
Output power factor	1.0		
Output Voltage Regulation	± 1% (Static); ± 5% (Dynamic)		
Output Voltage THDv	< 3% (Full Linear load)		
	< 5% (Full nonlinear load)		
Output Frequency	50/60 Hz ± 4 Hz (Line mode); 50/60 Hz ± 0.02 Hz (Battery mode)		
Over Load Capability (Online mode)	105%-125%: UPS transfer to bypass after 1 minute when the utility is normal 125%~130%: UPS transfer to bypass after 30 seconds when the utility is normal >130%:UPS transfer to bypass after 0.2 second when the utility is normal		
Over Load Capability (Battery mode)	105%-125%: UPS after 1minute shut down 125%~130%: UPS after 10 seconds shut down >130%: UPS after 0.2 second shut down		
Over Load Capability (Bypass mode)	105%~130% :shutdown after 10mins; 130%~200% :shutdown after 1mins; >200% :shutdown after 200ms		
Current Crest Ratio	3:1		

Outlets - Total	8*C13	8*C13	1*C19, 8*C13
Non-Programmable Receptacles	4*C13	4*C13	1*C19, 4*C13
Programmable Receptacles	4*C13	4*C13	4*C13
Transfer time			
AC mode <-> Batt. Mode	0 ms		
Inverter <-> bypass	4 ms typical		
Bypass			
Bypass Voltage Range	176-264Vac		
Bypass Frequency Range	Frequency Protection Range: +/-4Hz		
ECO Range	Same as the bypass		
Communication Section and User Interface			
Control panel LCD (English-Language)	Segment colorful screen (Colorful touch screen optional)		
LCD	Yes		
RS232 port	Yes		
USB port	Yes		
RS485 port	Yes		
SNMP Slot	Mini SNMP Card slot (Big Card slot optional)		
Emergency Power Off (EPO)	Yes		
Environment			
Operating Temperature	0 - 40 °C		
Storage Temperature	-25°C ~ 55°C (without batteries)		
Operating Humidity	0 - 95% (non -condensing)		
Storage Humidity	0 - 95% (non -condensing)		
Operating altitude	0 - 3000 (1000-3000 derating required)		
Protection Class	IP20		
pollution degree	II		
Overvoltage category	II		
Power distribution system	IT/TT/TN		
Audible Noise	≤55dB		
Regulatory Compliance			
Certification&Marketing	CE		
Environment	ROHS 2.0 (Reach)		
Safety	EN 62040-1:2008+A1:2013(CE) IEC/EN62040-1, IEC/EN60950-1		
EMC	IEC/EN62040-2 C2		
ISTA	ISTA Procedure 2A		
Others			
Generator Compatible	Yes		
Short Circuit	Hold Whole System		
Overheat	Line Mode: Switch to Bypass; Backup Mode: Shut down UPS immediately		
Low battery voltage	Alarm and Switch off		
EPO	Shut down UPS immediately		
Audible & Visual alarms	Line Failure, Battery Low, Overload, System Fault		
Leakage current	≤3.5mA(come with label)		
User Manual	English Language		
Parallel Operation Capability	NA		
Logo	ATENCO		

Accessories	
RS232 cable	1Pcs
USB cable	1Pcs
User manual	1Pcs
Mounting ears	2Pcs
Standing holders (option)	1set
SNMP Card (option)	1set
Battery PACK	
Battery Type	LiFePO4 (48V 50Ah)
Battery Number	15S1P
Charge Voltage	52.5V
Charge Current (max.)	10A
Package quantity(max.)	8
Communication	BMS、RS485、CAN
Product Size WxDxH (mm)	438*600*86
Certification&Marketing	TUV/CB
Enviroment	ROHS 2.0 (Reach)
Safety	UL1778 5th Edition CSA C22.2 NO.107.3-14,UL1640,UL1973 IEC62619
FCC	FCC Part 15, Subpart B, ClassA ANSI C63.4-2014
EMC	IEC/EN62040-2 C2
ISTA	ISTA Procedure 2A
UN	UN38.3

