



User Manual (cabinet)

RM11E 1-3kVA

Solutions behind the power

All rights reserved.

The information in this document is subject to change without notice.

Publish statement

Thank you for purchasing this series UPS.

This series UPS is an intelligent, single phase in single phase out, high frequency online UPS designed by our R&D team who is with years of designing experiences on UPS. With excellent electrical performance, perfect intelligent monitoring and network functions, smart appearance, complying with EMC and safety standards, The UPS meets the world' s advanced level.

Read this manual carefully before installation

This manual provides technical support to the operator of the equipment.

1:1



Special Symbols

The following are examples of symbols used on the UPS or accessories to alert you to important information:



RISK OF ELECTRIC SHOCK - Observe the warning associated with the risk of electric shock symbol.



CAUTION: REFER TO OPERATOR'S MANUAL - Refer to your operator's manual for additional information, such as important operating and maintenance instructions



This symbol indicates that you should not discard the UPS or the UPS batteries in the trash. This product contains sealed, lead-acid batteries and must be disposed of properly. For more information, contact your local recycling/reuse or hazardous waste center.



This symbol indicates that you should not discard waste electrical or electronic equipment (WEEE) in the trash. For proper disposal, contact your local recycling/reuse or hazardous waste center.

1 Introduction

The extended battery pack can be added to UPS to extend the available battery time (See Table1). Up to four EB PS can be installed with the ups.

Table 1. Battery Runtimes (in Minute s) at 100 % Load (Tower Models)

Model	Battery type	Internal Battery Q'ty	Internal Batteries Run time	+ 1EBP	+ 2EBPs	+ 3EBPs	+ 4EBPs
1KVA	12V/9AH	2	3'	15'	25'	40'	53'
2KVA		4	3'	15'	25'	40'	53'
3KVA		6	3'	17'	31'	52'	69'

NOTE Battery times are approximate and vary depending on the load configuration and battery charge.

2 Safety Warnings

IMPORTANT SAFETY INSTRUCTIONS SAVE THESE INSTRUCTIONS

This manual contains important instructions that you should follow during installation and maintenance of the EBP. Please read all instructions before operating the equipment and save this manual for future reference.

CAUTION



- Batteries can present a risk of electrical shock, or burn from high short-circuit current. Observe proper precautions. Servicing should be performed by qualified service personnel knowledgeable of batteries and required precautions. Keep unauthorized personnel away from batteries.
- Proper disposal of batteries is required. Refer to your local codes for disposal requirements.
- Never dispose of batteries in fire. Batteries may explode when exposed to flame.

3 Installation

Inspecting the Equipment

If any equipment has been damaged during shipment, keep the shipping cartons and packing materials for the carrier or place of purchase and file a claim for shipping damage. If you discover damage after acceptance, file a claim for concealed damage.

NOTE Check the battery recharge date on the shipping carton label. If the date has passed and the batteries were never recharged, do not use the EBP. Contact your service representative.

To install the optional EBP(s) for a UPS:

1. Remove the front cover of each EBP (see Figure 1).

Press the panel side with LCD display, hold the other side and quickly extract it, then extract the other side with display. (see Fig. 1)

NOTE A ribbon cable connects the LCD control panel to the UPS. Do not pull on the cable or disconnect it.

When remove the panel, Operate as the following right Figure shows instead of the left one.

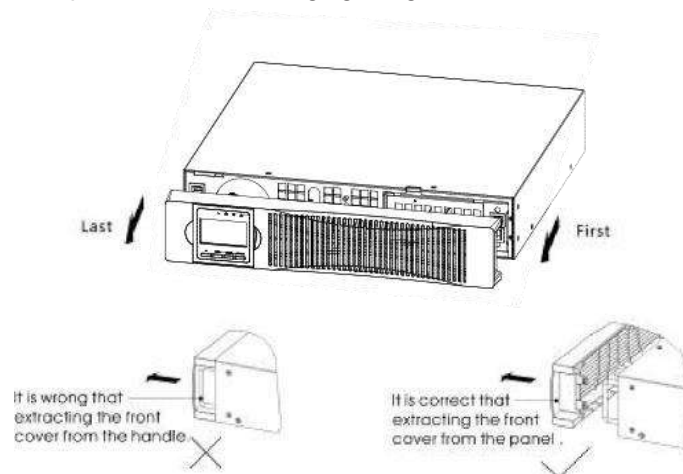

Figure1 Removing the EBP Front Cover

2. On the bottom of the UPS front cover, remove the EBP cable knockout (see Figure 2).

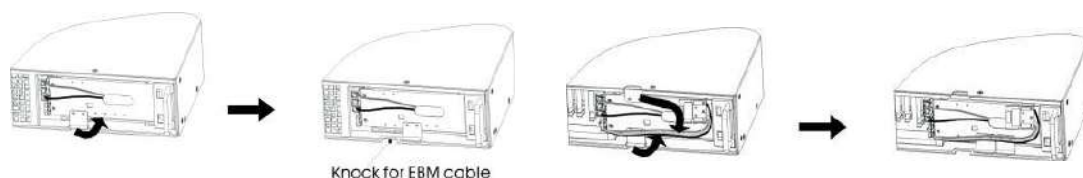

Figure2 Removing the UPS and EBP Cable Knockout

3. Plug the EBP cable(s) into the battery connector(s) as shown in Figure 3.

A small amount of arcing may occur when connecting an EBP to the UPS. This is normal and will not harm personnel. Insert the EBP cable into the UPS battery connector quickly and firmly. Up to four EBPS may be connected to the UPS. Connect red to red, black to black, and yellow to yellow. Press the two parts tightly together to ensure a proper connection.

To connect a second EBP, unclip the EBP connector on the first EBP and pull gently to extend the wiring to the EBP connector on the second EBP. Repeat for any additional EBPS.

Another kind of connection is, can pass from the rear panel of the EBP SB50 terminal received UPS and parallel to the other EBP, pay attention to the positive and negative electrodes

4. Verify that the EBP connections are tight and that adequate bend radius and strain relief exist for each cable

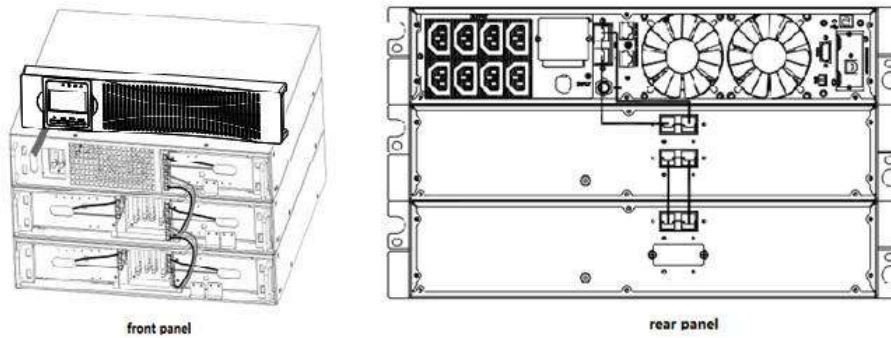

.Figure3 Typical EBP Installation

5. Replace the EBP front cover.

To replace the cover, verify that the EBP cables are routed through the EBP cover knockouts, cover connects with the cover hook near the left side of the EBP cabinet. Repeat for each additional EBP.

Put the front panel side with display to the panel port, put another side to the other two ports, then press it until the panel and the chassis are combined tightly.

6. Verify that all wiring connecting the UPS and EBP(s) is installed behind the front covers and is inaccessible to users.

7. Return to Step 1 to continue the EBP installation

4 Operation

Configuring Battery Settings

Set the UPS for the number of EBPs installed.

To ensure maximum battery runtime , configure the UPS for the correct

number of EBMs, refer to Table 8 for the appropriate setting of battery numbers and type. Use the up and down buttons to select the number of battery strings according to your UPS configuration:

Table2. Battery number Configuration

All UPS and EBP Cabinets	Number of Battery Strings
UPS only (internal batteries)	1 (default)
UPS+1EBP	3
UPS+2EBPs	5
UPS+3EBPs	7
UPS+4EBPs	9
NOTE The UPS contains one battery string; each EBP contains two battery strings.	

5 Maintenance

Replacing Batteries



NOTE DO NOT DISCONNECT the batteries while the UPS is in Battery mode.

The EBP can be replaced when UPS is ON but be aware that if the utility fails at that time, the load of the UPS may NOT be protected.

If you prefer to remove input power to change the batteries.

WARNING

- Servicing should be performed by qualified service personnel knowledgeable of batteries and required precautions. Keep unauthorized personnel away from batteries.
- Batteries can present a risk of electrical shock or burn from high short circuit current. Observe the following precautions: 1) Remove watches, rings, or other metal objects; 2) Use tools with insulated handles; 3) Do not lay tools or metal parts on top of batteries; 4) Wear rubber gloves and boots.
- When replacing batteries, replace with the same type and number of batteries or battery packs. Contact your service representative to order new batteries.
- Proper disposal of batteries is required. Refer to your local codes for disposal requirements.
- Never dispose of batteries in a fire. Batteries may explode when exposed to flame.

Replacing RT EBPs



CAUTION

The EBP is heavy. Lifting the cabinet requires a minimum of two people.

1. If the battery fault, the following steps are provided for modular unit to replace the new battery pack.
2. Remove the front panel of the battery box.
3. Remove the connection cables between battery box and UPS. Release the screw of the baffle of the battery pack as the Fig4 shows, then remove the baffle from the left.

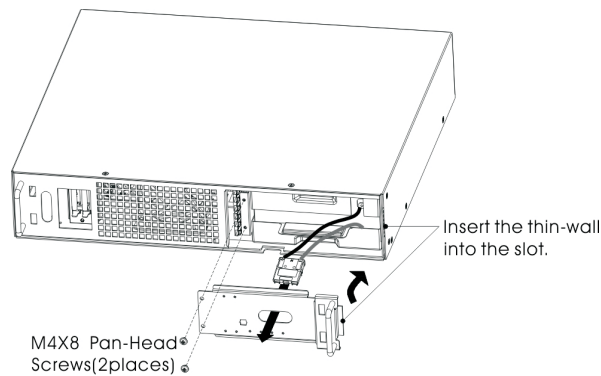

Fig.4 Installation for battery pack baffle(UPS)

4. Grasp the handle in front of the battery pack, take out of it and hold it, then remove the battery pack. (see Fig.5)

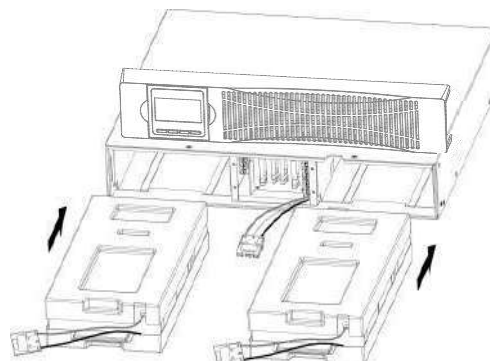

Fig.5 Installation for battery pack

5. Hold the middle of the new battery pack, insert it. Make sure that the whole battery pack is in position. (see Fig.6)

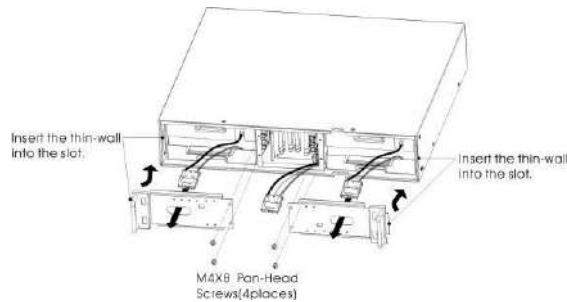

Fig.6 Installation for battery pack baffle

6. If the fuse melting, replace it from the front. (see Fig.7)

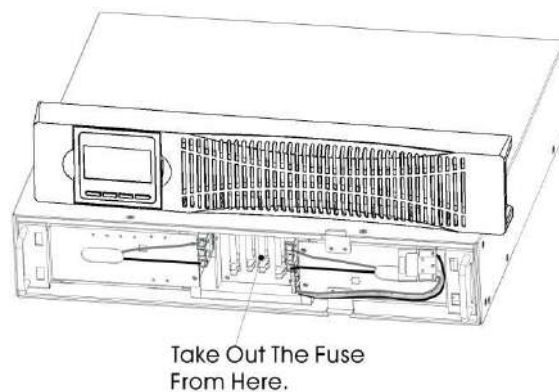

Fig.7 Replacement of fuse

Testing New Batteries

To test new batteries:

1. Plug the UPS into a power outlet for 48 hours to charge the batteries.
2. Start up the UPS by pressing the start up combination button.
3. Press the battery test combination button to activate the battery test.

The UPS starts a battery test if the batteries are fully charged, the UPS is in Normal mode with no active alarms, and the bypass voltage is acceptable. During the battery test, the UPS transfers to Battery mode and discharges the batteries for 10 seconds. The LED indicators of the front panel stop cycling when the test is completed.

Recycling the Used Battery

Contact your local recycling or hazardous waste center for information on proper disposal of the used battery or UPS.

WARNING



■ Do not dispose of the battery or batteries in a fire. Batteries may explode. Proper disposal of batteries is required. Refer to your local codes for disposal requirements.

■ Do not open or mutilate the battery or batteries. Released electrolyte is harmful to the skin and eyes. It may be toxic.

CAUTION



Do not discard the battery pack or the batteries in the trash. This product contains sealed, lead-acid batteries and must be disposed of properly. For more information, contact your local recycling/reuse or hazardous waste center

CAUTION



Do not discard waste electric al or electronic equipment (WEEE) in the trash. For proper disposal , contact your local recycling/reuse or hazardous waste center.

6 Rear Panel Description

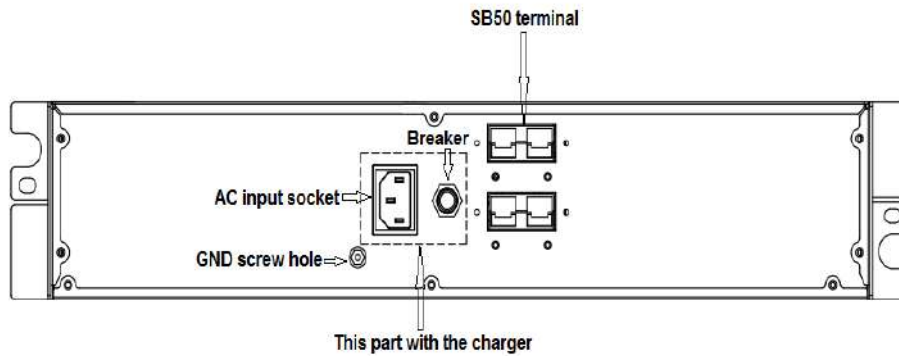

Fig.8 Battery pack rear panel

7 Specifications (for with charger model)

MODEL		1K-EBP	2K-EBP	3K-EBP
Input	Voltage	208/220/230/240VAC		
	Frequency	50V/6A0C H z		
	Input Protection	Resettable Circuit Breaker		
CHARGER OUTPUT	DC Voltage	27.4/41.0 ±1%VDC	54.7/82.1 ±1%VDC	82.5/109.4 ±1%VDC
	DC Current	1.0A		
	Output Protection	Fuse		
BATTERY	Battery Type	sealed, maintenance free, valve regulated, lead acid		
	Battery Type (EBP)	2 strings of (2/3) 12V/ 9AH	2 strings of (4/6) 12V / 9AH	2 strings of (6) 12V/ 9 AH 1 string of (8) 12V/ 9 AH
	Recharge Time	4 hours to 90%		
Accessory		User Manual, AC input cord ,plastic base ,cabinet installation bracket		

