



User Manual

SNMP - TM220

All rights reserved.

The information in this document is subject to change without notice.

Publish statement

Thank you for purchasing this series UPS.

This series UPS is an intelligent, single phase in single phase out, high frequency online UPS designed by our R&D team who is with years of designing experiences on UPS. With excellent electrical performance, perfect intelligent monitoring and network functions, smart appearance, complying with EMC and safety standards, The UPS meets the world' s advanced level.

Read this manual carefully before installation

This manual provides technical support to the operator of the equipment.

Contents

1. Product Introduction	2
1.1. Overview.....	2
1.2. Functions	2
1.3. Features	3
1.4. Network Interface	3
1.5. Definition of Indicator Lights	3
2. TM220 Installation	4
2.1. TM220 Installation & Connection.....	4
2.2. SNMP-Tool Installation & Usage	4
3. Web Login	9
3.1. Logging in Management Page	9
3.2. Changing IP Address.....	9
4. Web Monitoring Management.....	10
4.1. Real-time Information	10
4.2. Parameter Settings.....	13
4.3. History	20
4.4. About	21
5. Shutdown Protection Software--SNMP_Protector	23
5.1. SNMP_Protector Installation	23
5.2. SNMP_Protector Usage	23
6. Centralized Monitoring Software--SNMP Management	26
6.1. SNMP Management.....	26
6.2. SNMP Management Usage	26

1. Product Introduction

1.1. Overview

TM220 is a built-in network SNMP card independently . It supports SNMPv1/v2 and v3 protocols, features e-mail alarm, historical events and historical data storage. Picture is shown as below:

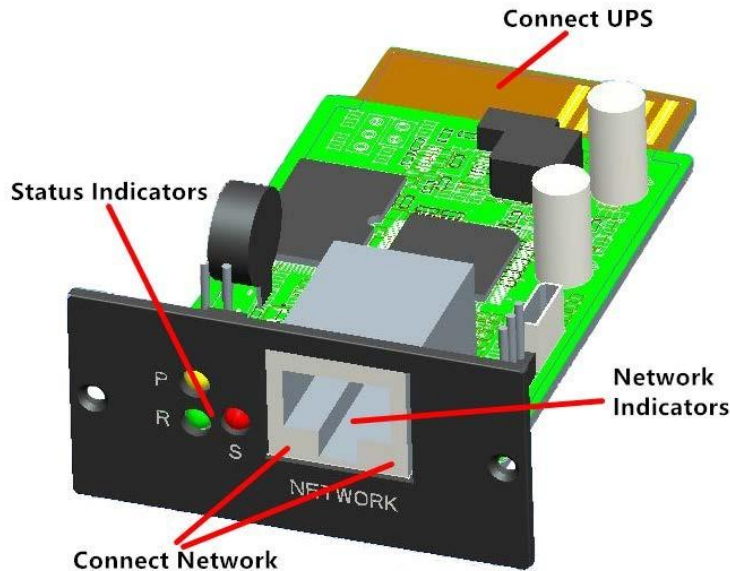

1.2. Functions

- Support multiple operating systems (Windows 、 Mac 、 Linux)
- UPS can be monitored remotely through the network;
- Can realize web-based user interface;
- Support e-mail alarm;
- Multi-user permission management;
- Support DHCP;
- Support remote self-testing, shutdown and restart UPS functions (UPS support required);
- Support telnet, SSH, Web page configuration;
- Support scheduled tasks (timed self-test, power on/off);
- Historical events and historical data storage functions;
- Remote UPS monitoring and management can be performed through HTTP, SNMP, SSH, Telnet;
- Complete equipment event handling (including event recording and notification);

1.3. Features

- Networking methods: IP-based LAN, WAN, Internet, wireless Ethernet, etc.;
- User permission management, safe, confidential and reliable;
- Support multiple configuration management methods such as Telnet, SSH, Web;
- Support scheduled task function, allow setting scheduled UPS on/off, scheduled battery discharge, etc.
- Support storage of 50, 000 historical data and 5, 000 historical event records;
- Built-in ultra-long-life system clock, support automatic timing to achieve time synchronization;
- Support SNMP V1/V2/V3, HTTP, DHCP, SSH, SSL and other network protocols; Support IPV6;
- Support E-mail alarm function;

1.4. Network Interface

10/100M RJ45 Ethernet interface, used to connect to the switch.

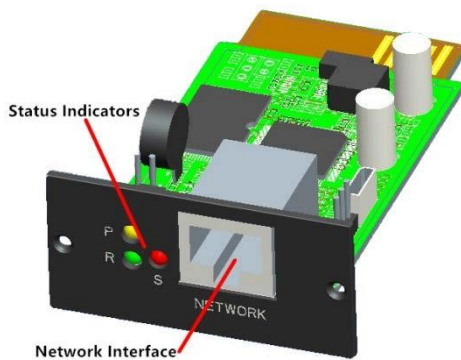

1.5. Definition of Indicator Lights

Power indicator yellow (Power), always on;

Status indicator red (Status), off when normal, always on when failure;

Run indicator green (Run), flashing when the program is running normally.

2. TM220 Installation

2.1. TM220 Installation & Connection

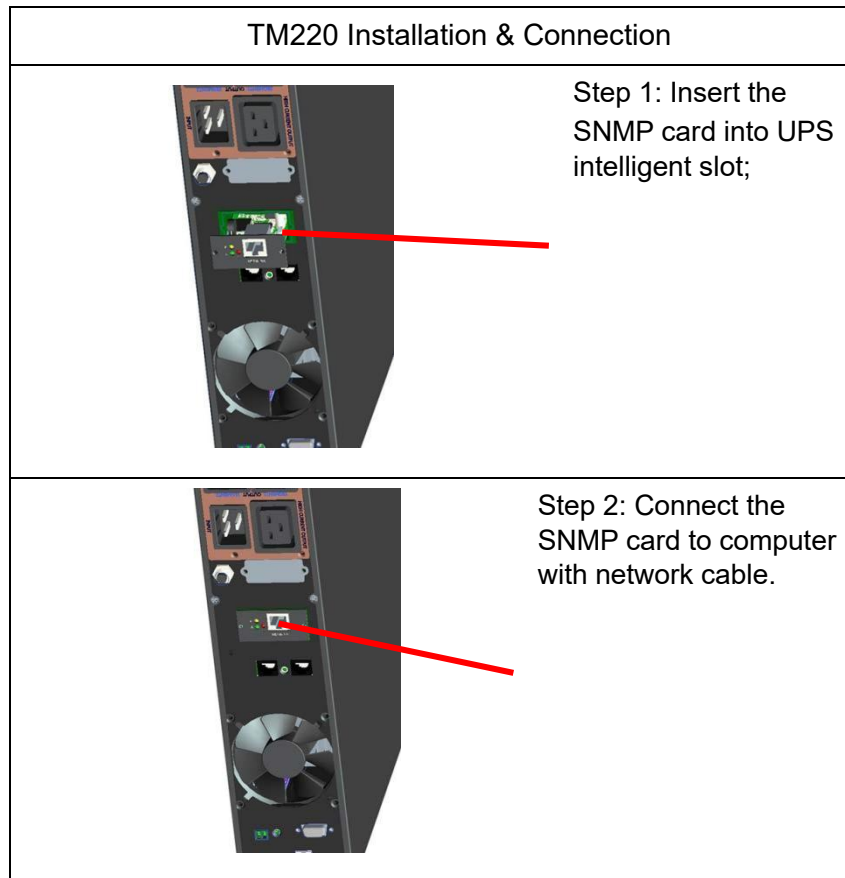

2.2. SNMP-Tool Installation & Usage

A. Download installation files from <http://download.ksdatacloud.com>, execute “SNMP_Tool_20xxxxxx_V1.x.x.exe” to start the install the software, users can find the icon of software in “Start menu--All Programs--SNMP_Tool” after installation.

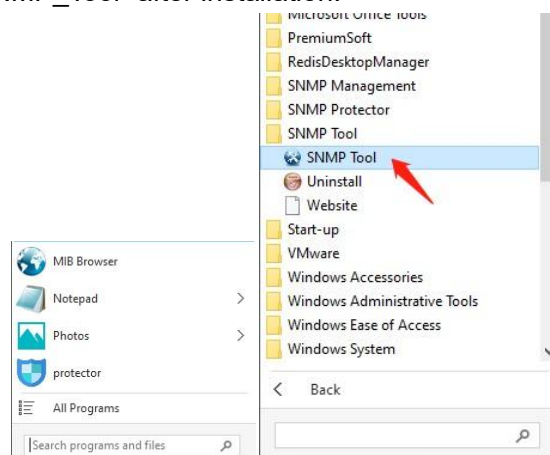

B. Device IP address searching

If users can't know the current IP information because changing the IP address or other reasons, you can search the IP address of SNMP card by installed “SNMP-Tool”, the specific methods are as follows: ①Click“Device Search”, ②Choose current network port, click”Refresh”to query the SNMP card IP in the LAN.

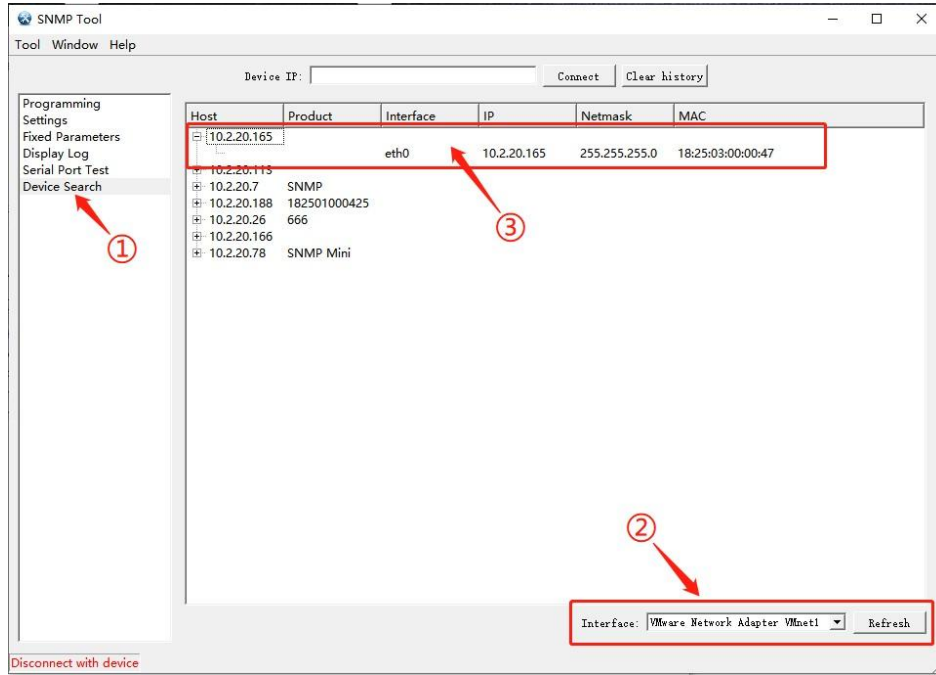

C. Software version upgrade

(1) Connect the device, input the IP of the device that needs upgrade, click “Connect” After the connection is successful, there will be a green font in the lower left corner of the tool interface that displays “Connected to device”.

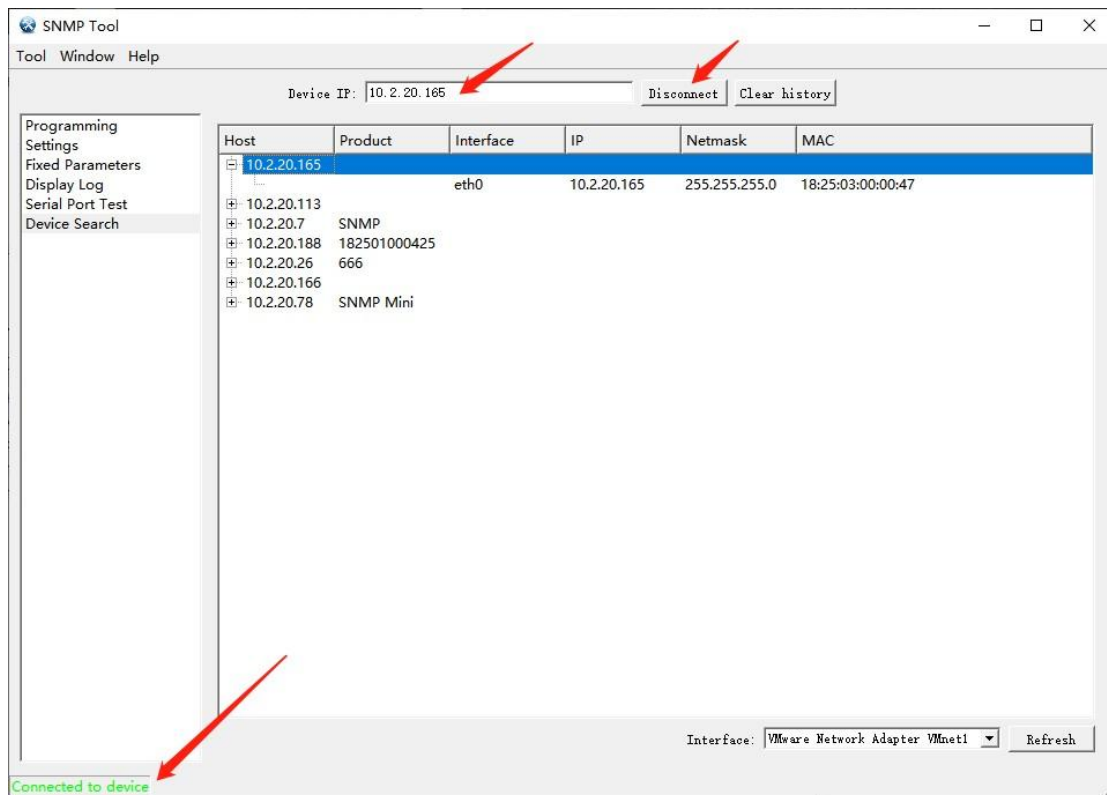

(2) Upgrade the firmware , select the new version file(file type is firmware -20xxxxx-v1.x.x.bin), and click “Programming”, it will prompt “Programming finish”.

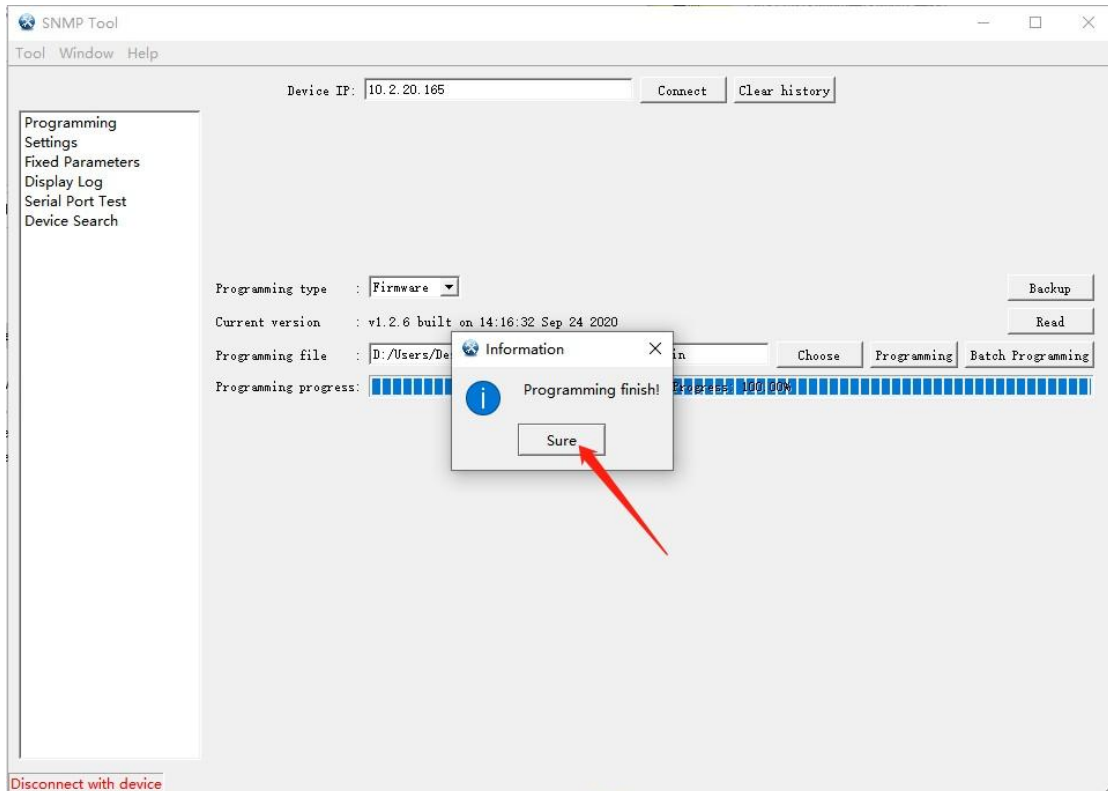
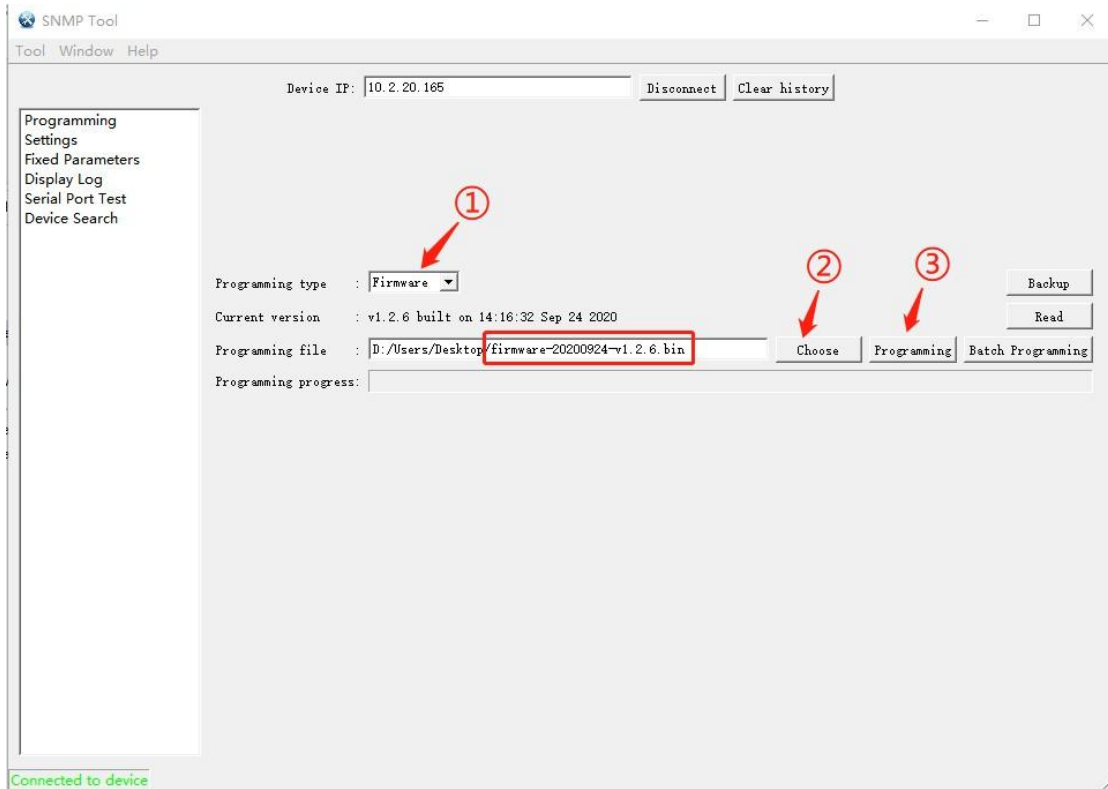

Check whether the firmware upgrade is successful, as shown in the figure below:
Programming --Programming type--select "Firmware"-- Read -- check the current program version.

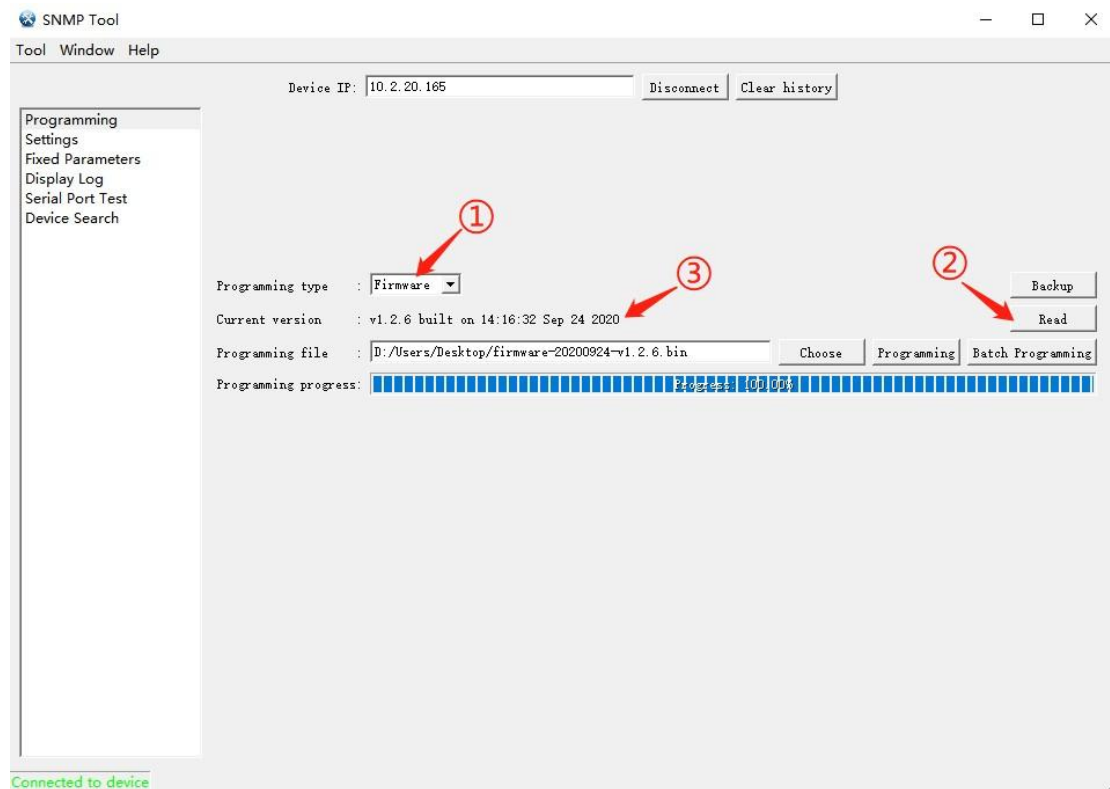

(3) Upgrade the application, (1) Programming type select "APP" (2) select the new version file (file type is snmp-20xxxxx-v1.x.x.x.bin), (3) click "Programming", wait about 30 seconds, it will prompt "Programming finish". And then log in the background of SNMP card to check the software version.

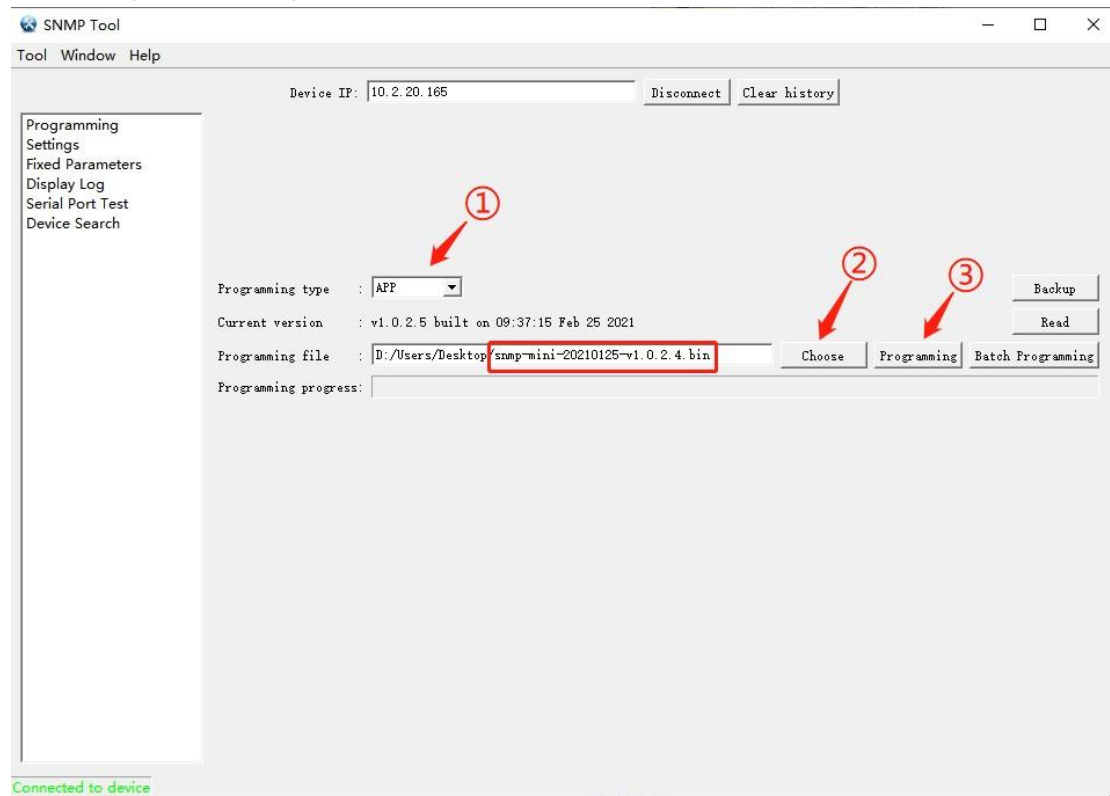

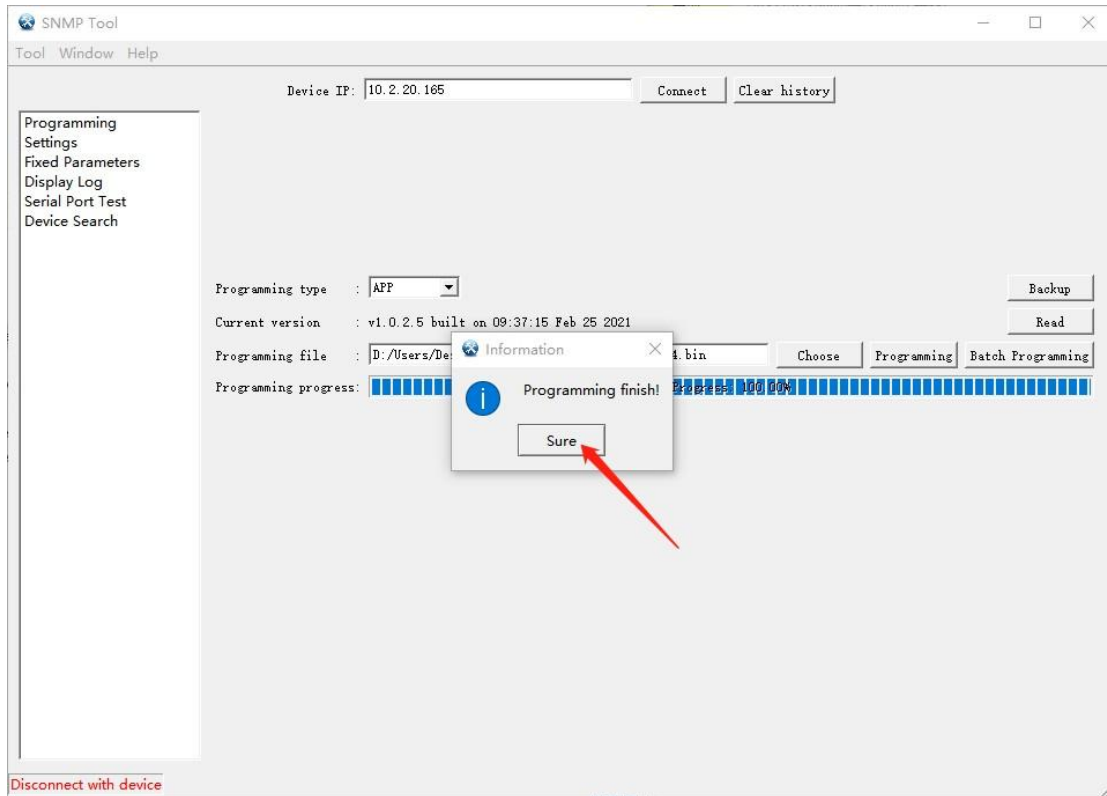

Check whether the application upgrade is successful, as shown in the figure below: Programming - Programming type select "APP"- Read - check the current software version.

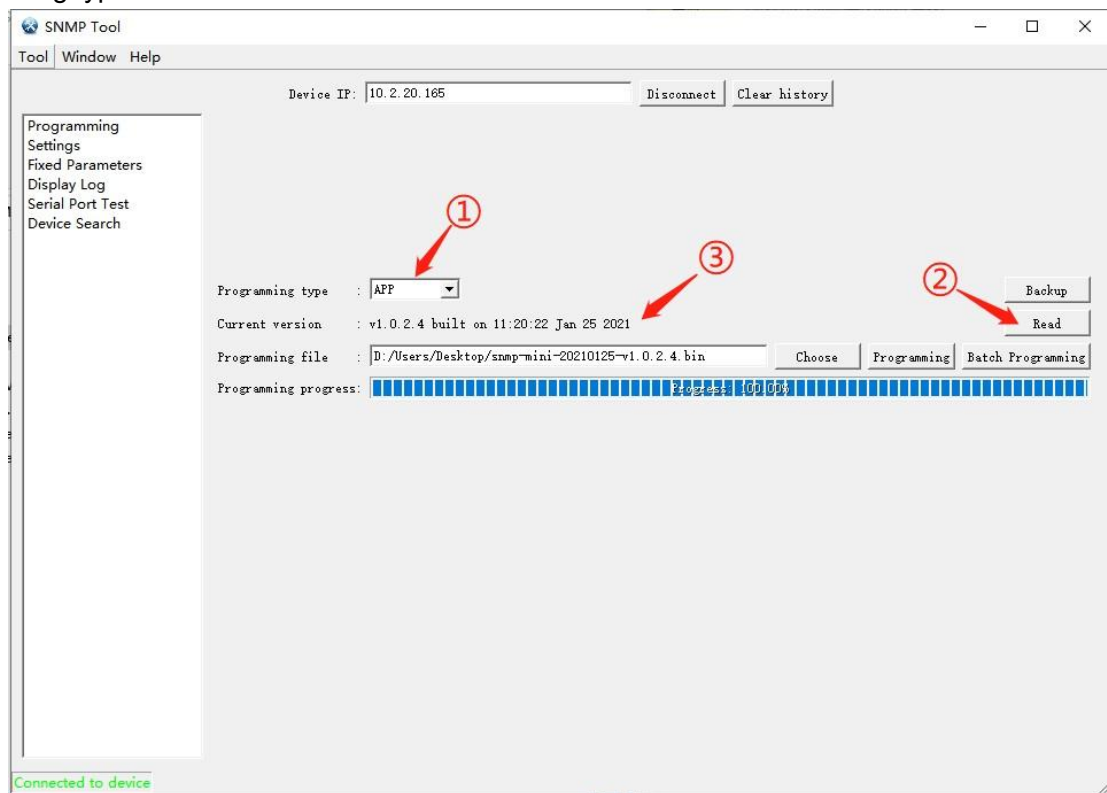

3. Web Login

3.1. Logging in Management Page

Connect the computer directly to the SNMP card, and set the computer IP to the same network segment as the SNMP default IP (for example, the computer IP is set to: 192.168.137.101), and confirm that the network communication between the computer and the SNMP card is normal (verify by means of ping packets); open the browser (Google Chrome or IE browser is recommended), enter the default IP address “192.168.137.100” of the SNMP network card, enter the account and password (the default is admin), and log in to the SNMP monitoring system.

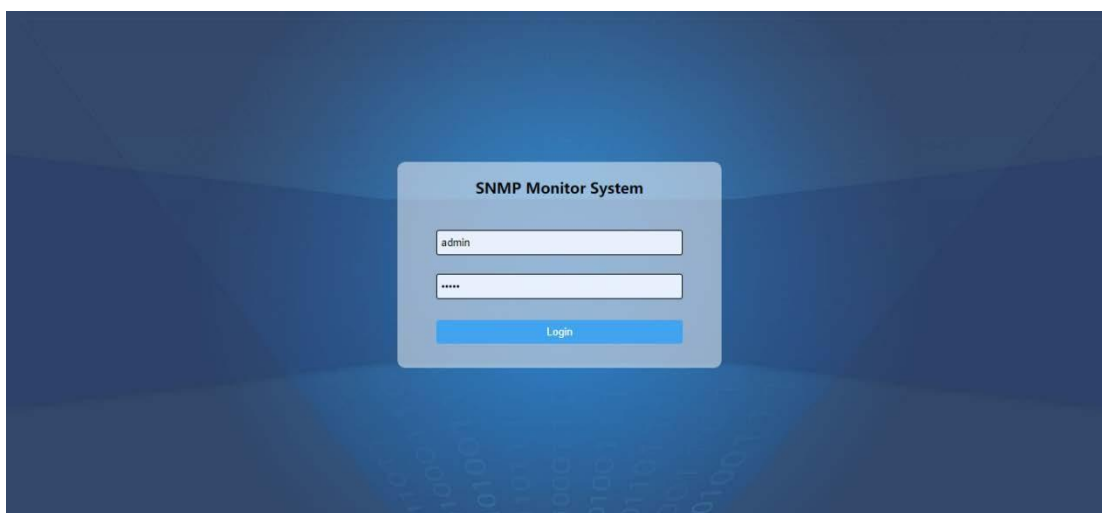

The method to modify the computer IP is as follows:

Open “Network & Internet”, ①Select “Ethernet”, ②Click “Change adapter options”, double click the Ethernet connected, ③Click “Properties”, ④Double click “Internet protocol version 4(TCP/IPv4)”, ⑤Select “Use the following IP address:”, fill in the IP address information of the same network segment as the SNMP card(for example:IP address is 192.168.137.101, subnet mask is 255.255.255.0, default gateway is 192.168.137.1) ⑥Click “OK”.

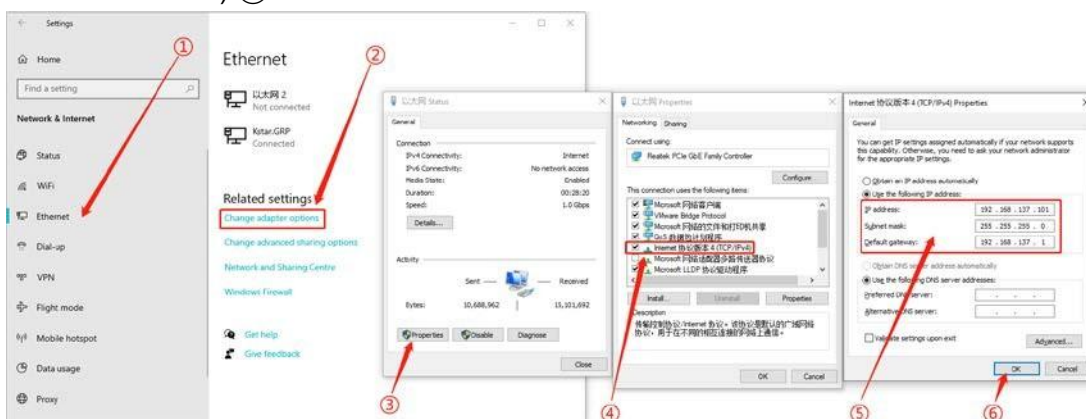

3.2. Changing IP Address

Parameter settings - Network -- IPV4, set to automatically obtain IP (select On for DHCP) or static IP address (select Off for DHCP), set the static IP address of SNMP card, and fill in the corresponding subnet mask and gateway; when domain name resolution is used, you need to set the DNS server; click “Submit” to confirm after completing the settings, as shown in the figure below:

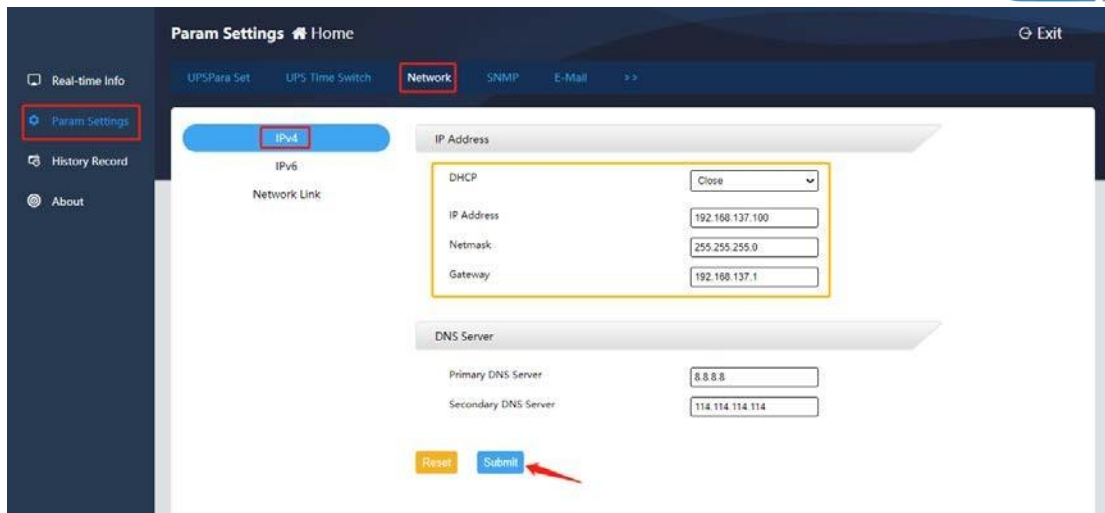

4. Web Monitoring Management

4.1. Real-time Information

A. UPS Basic Information

This item allows viewing basic UPS information, including UPS information, battery information and rated information, as shown in the following figure:

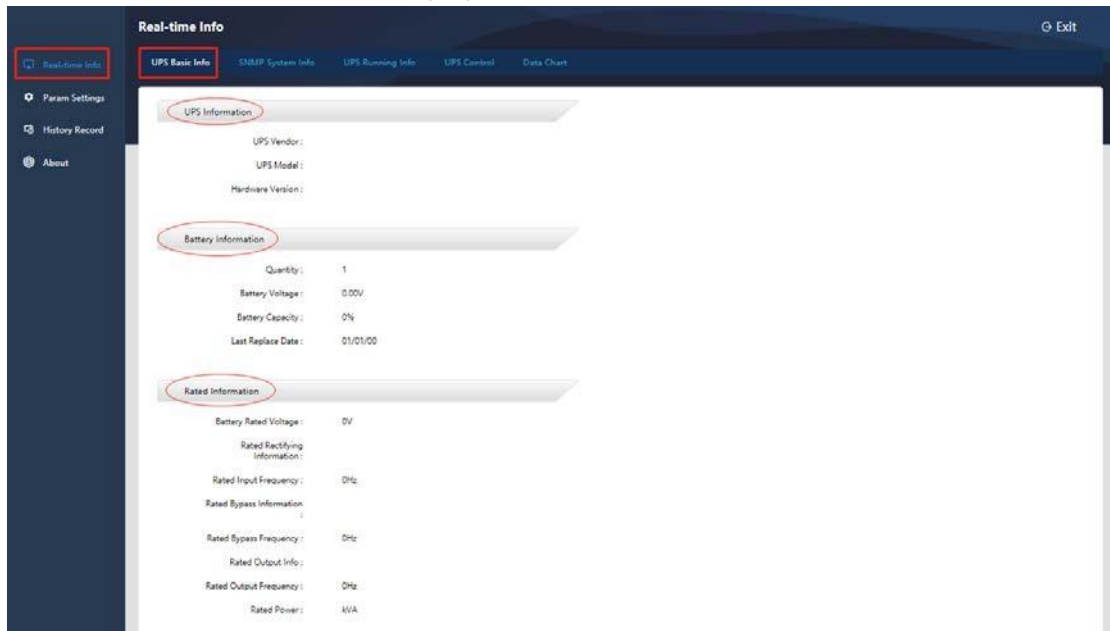

B. SNMP System Information

This item allows viewing system information (software version), network information (IP information), as shown in the figure below:

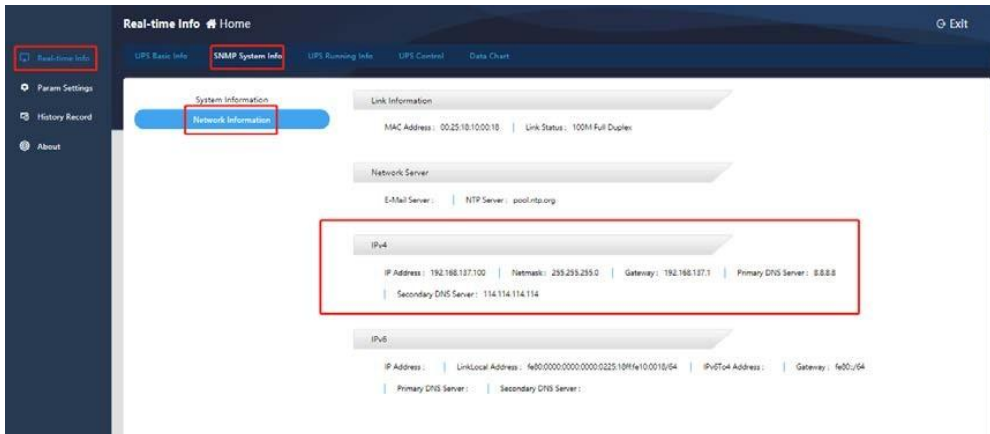
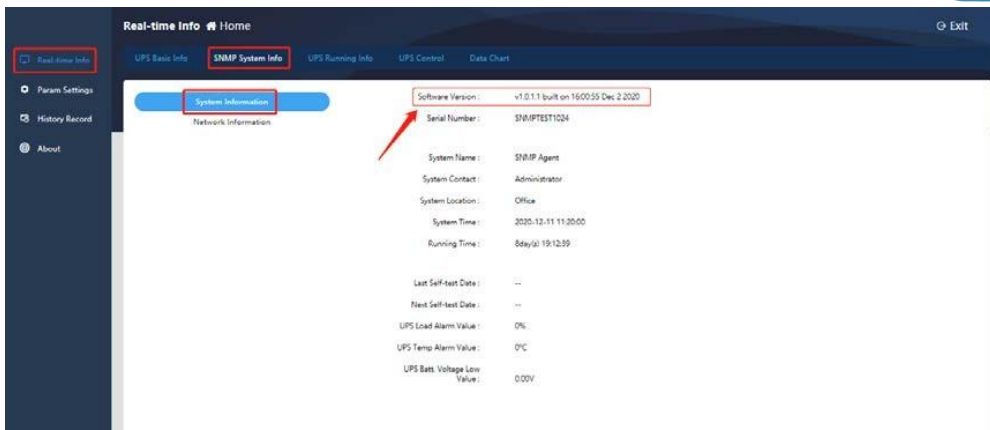

C. UPS Operation Information

The content of UPS operation information is different according to the selected communication protocol. Taking MegaTec1:1 protocol as an example, UPS operation information includes input information, output information, and battery information, as shown in the following figure:

Input information:



Output information:



Battery information:



D. UPS Control

The UPS control content is different according to the selected communication protocol. Take the MegaTec1:1 protocol as an example, it includes manual UPS self-check, manual power on/off and buzzer on/off control, as shown in the figure below;

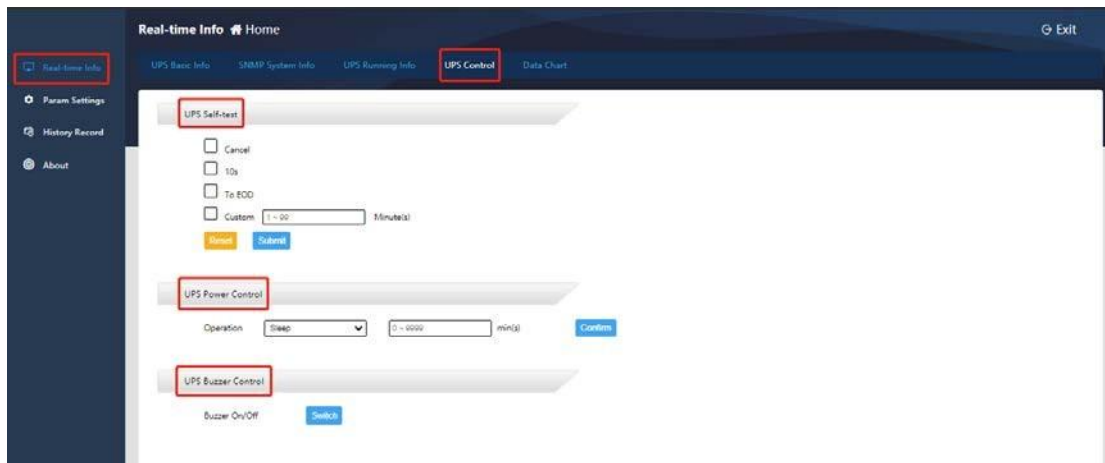

E. Data Chart

This item can be used to query the single day operating data change curve of the equipment by selecting a specific date. The data types include temperature (°C), output voltage (V), and load (%). You can select or cancel the type to be displayed by clicking the mouse. The curve recording interval is 90 minutes.



4.2. Parameter Settings

4.2.1. Parameter Settings

A. UPS Parameter Settings

Here you need to ①Select the UPS protocol according to the actual situation on site, ②Fill in the battery information、device ID ③Data store cycle, ④Customize communication parameters (no need to be set by default), after parameter setting, ⑤Click "Submit" and it's effective, as shown in the figure below:

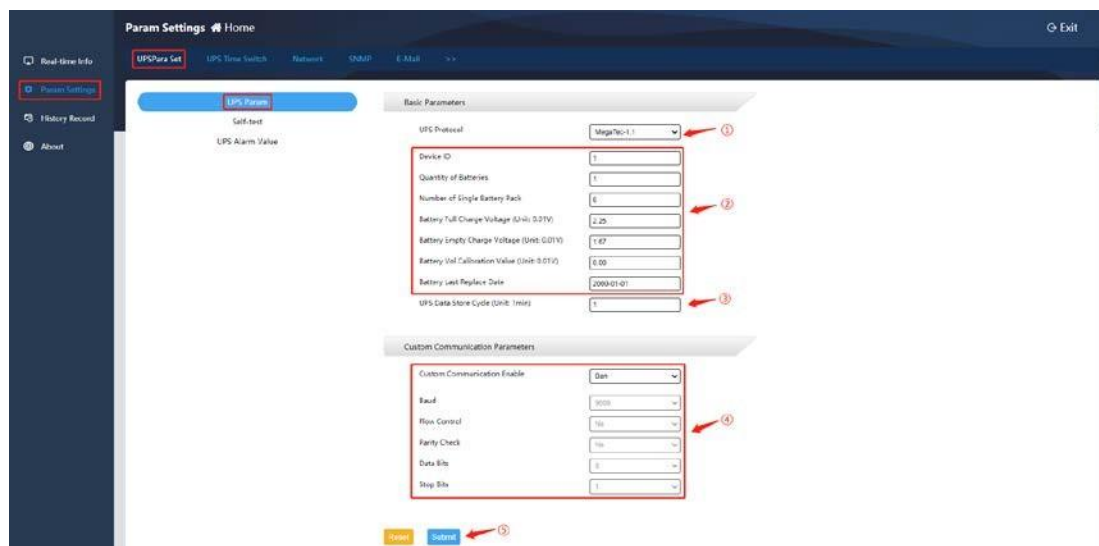

B. Self-check Settings

This function depends on whether the UPS host has a self-check function. The UPS self-check cycle can be weekly/monthly, and the self-check time can be customized, 10 seconds or until the battery voltage is low. Click [Submit] after completing the setting, as shown in the figure below:

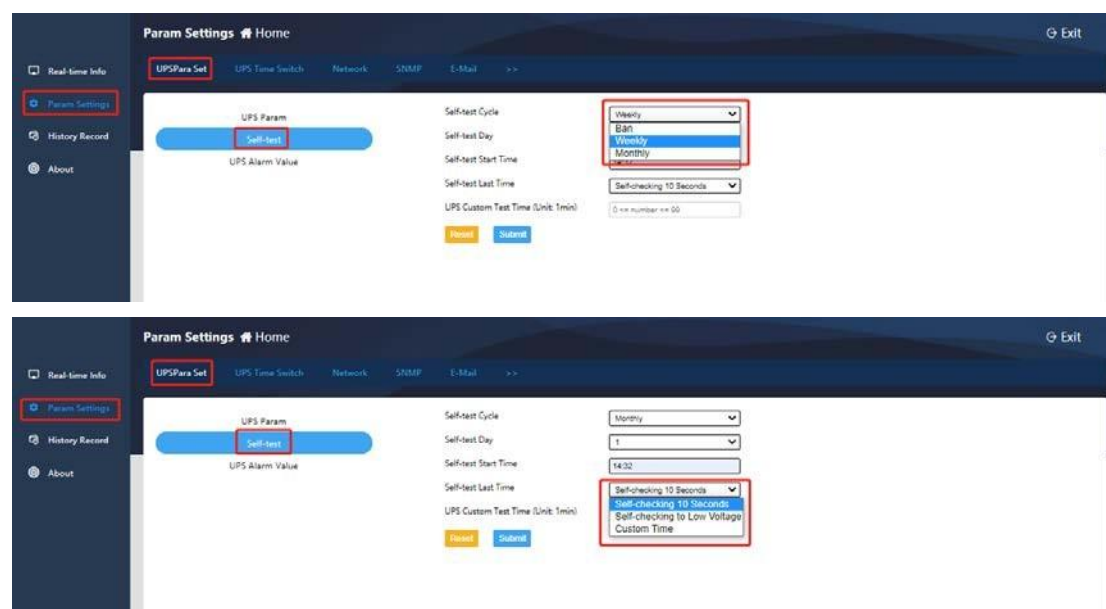

C. UPS Alarm Value Setting

This item allows customizing the UPS communication loss time (for example, if 30 seconds is set, the UPS is offline when the communication is lost for 30 seconds), load alarm value, temperature alarm value, battery voltage low alarm value, UPS input/output voltage alarm Value, UPS alarm activation times

(for example, if the setting value is 3, it will output alarm information when the program returns 3 consecutive polls); after completing the settings, click [Submit] to confirm.

Note: Except UPS communication loss time and UPS alarm activation times, when other custom alarm values are set to 0, means this type of alarm is not enabled.

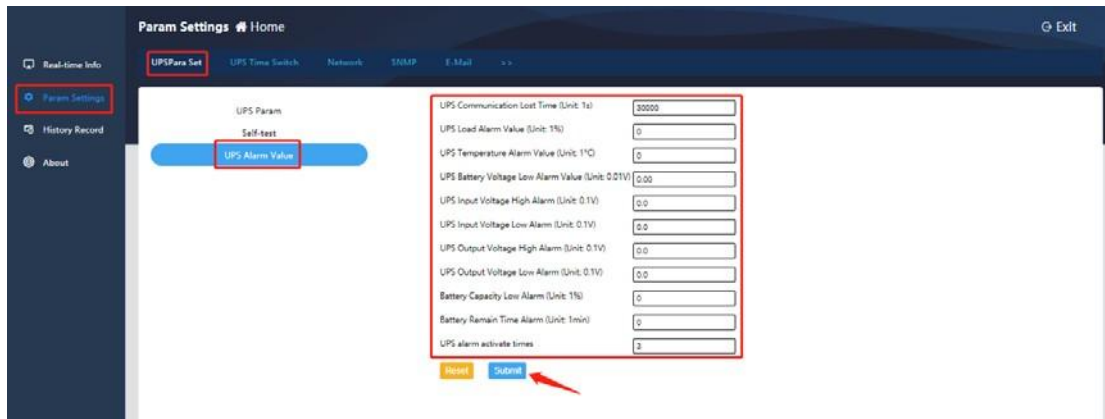

4.2.2. UPS Time Switch

A. UPS Shutdown Action

This function allows selecting the time period of shutdown, shutdown conditions, and execution time of shutdown. After setting, click [Set] to confirm:

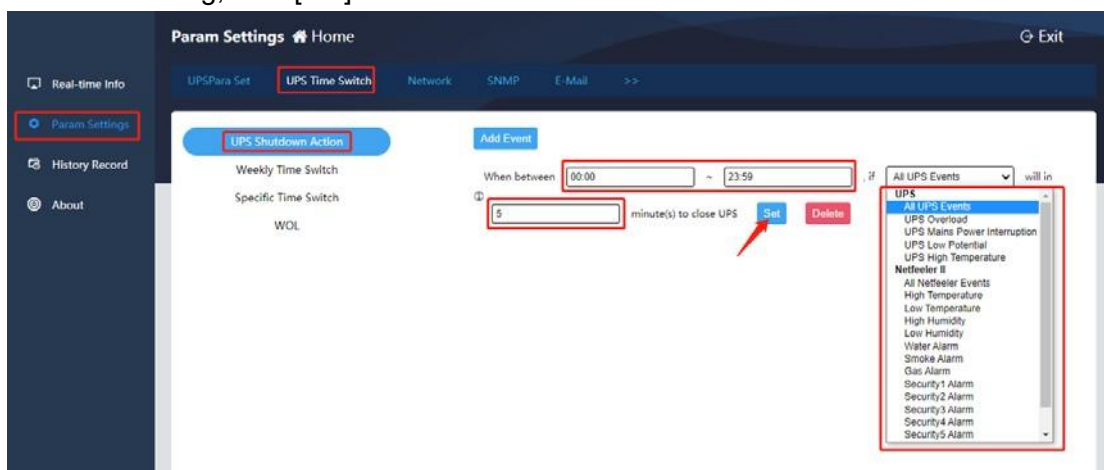

B. Weekly Time Switch

This setting takes one week as a cycle. You can set the specific time of one day or several days in the cycle to perform the power on/off action, and you can set the minutes of sending an alarm before shutdown. After completing the setting, click [Submit] to confirm, as shown below:

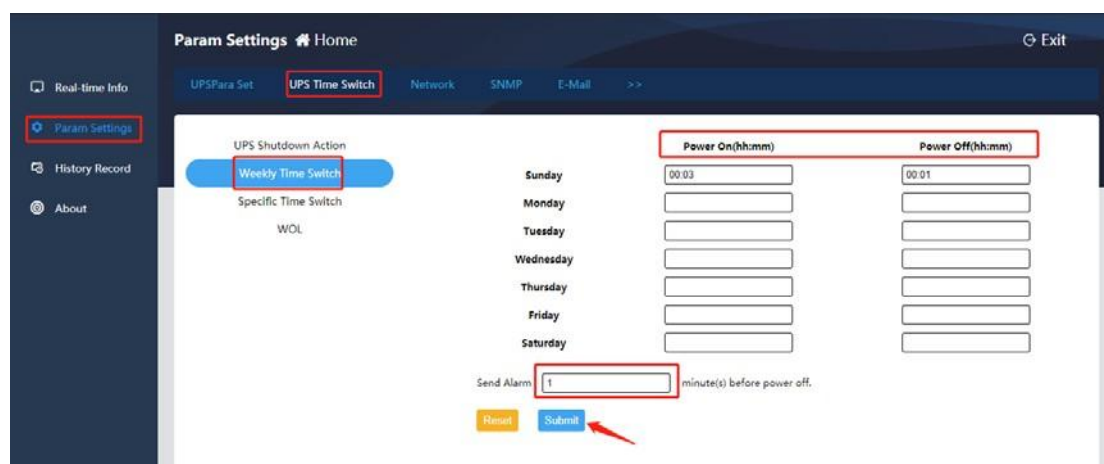

C. Specific Time Switch

This item allows setting the specific date and time to perform the power on/off action, and can set the minutes of sending an alarm before shutdown. After completing the setting, click [Submit] to confirm, as shown below:

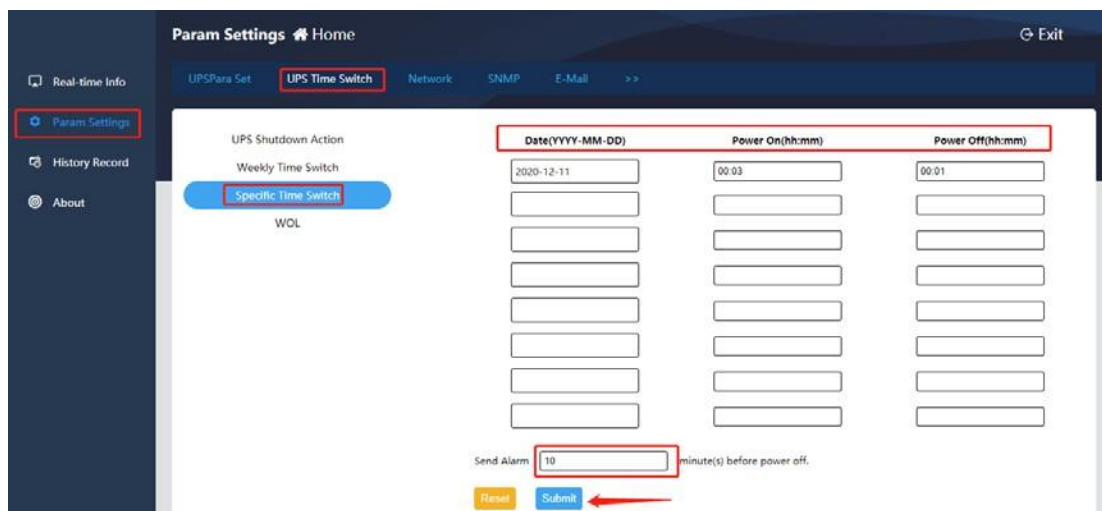

D. WOL

This item allows setting wake-up of specific host (the computer mainboard should support wake-up setting function), set to wake up when the power is restored or wake up when the power reaches the set percentage. After completing the settings, click [Submit] to confirm, as shown below:

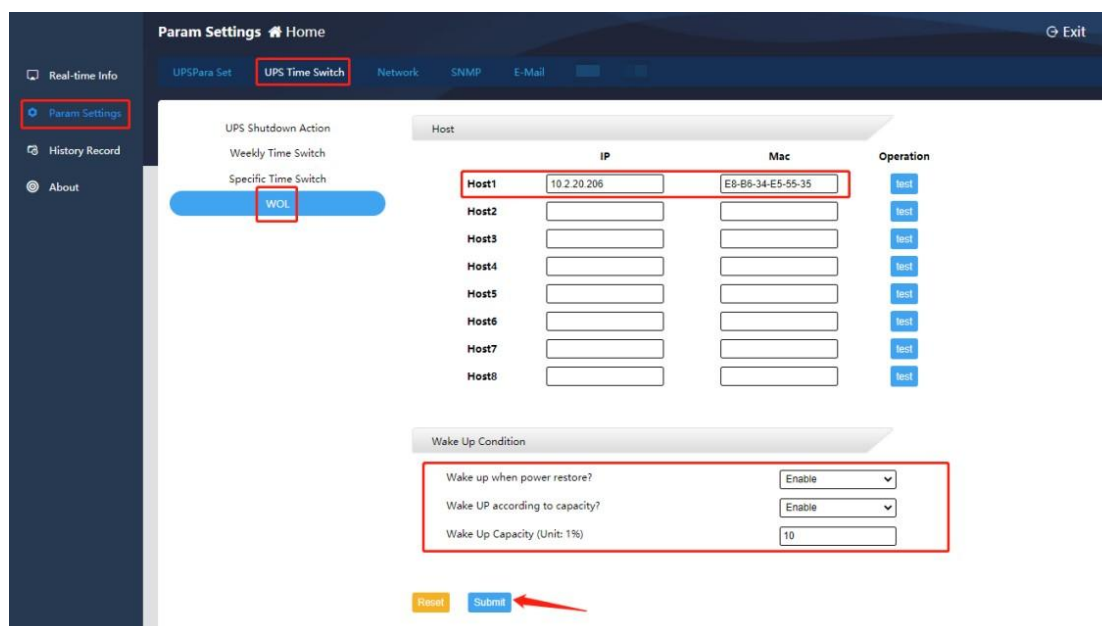

4.2.3. Network Settings

This item allows setting the static IP address of the SNMP card, filling in the corresponding subnet mask and gateway, and setting the DNS server when using the domain name resolution function; click [Submit] to confirm after completing the settings, as shown below:

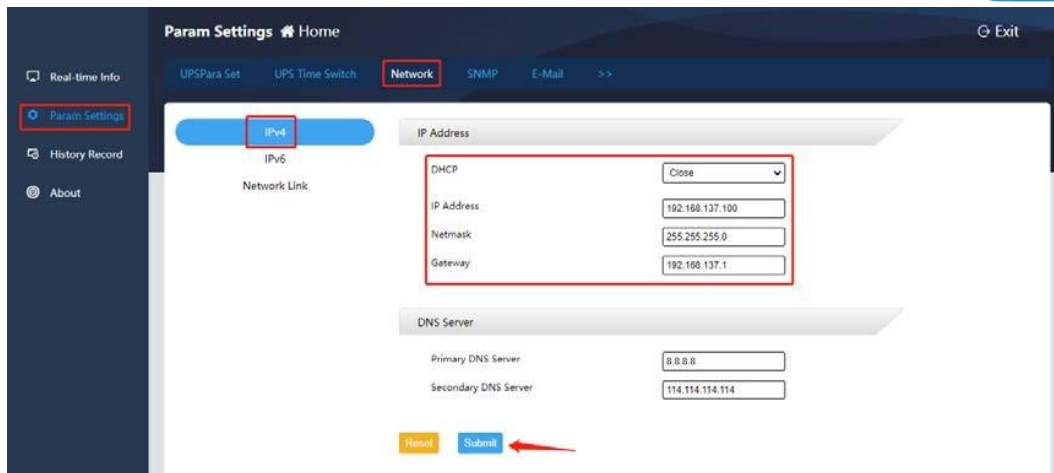

4.2.4. SNMP Settings

A. System Settings

This item allows changing the system information (system name, system administrator, system location), and setting the SNMP port. The default Agent port is 161 (the data transmission port for uploading real-time data when the platform issues polling instructions), and the Trap port is 162 (data transmission port for real-time upload of alarm information). After completing the settings, click [Submit] to confirm, as shown in the figure below:

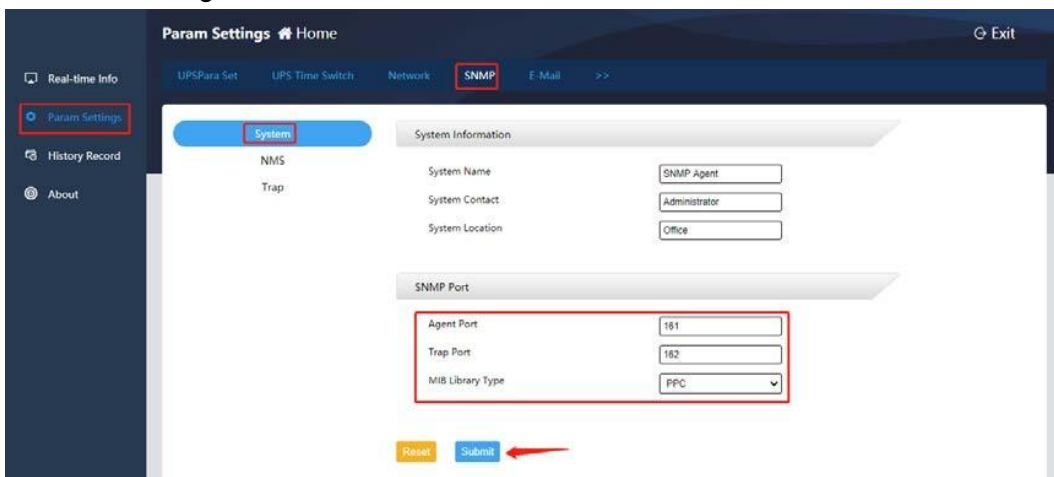

B. NMS Settings

If no IP address is set, the card has no access restrictions. Any IP can obtain the SNMP card operating data by visiting the SNMP card; if the IP, community string and version are set, only the IP added in the settings can visit the device;

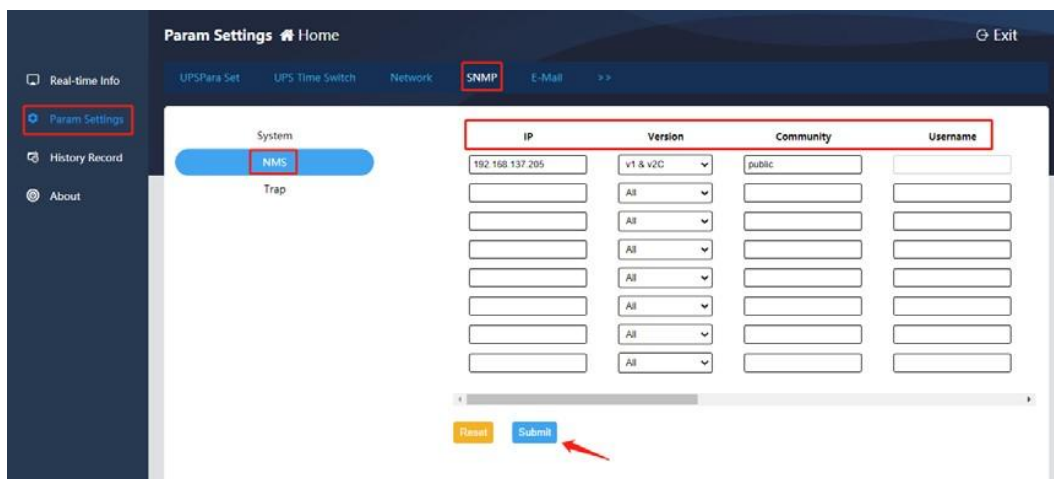

C. Trap Settings

This item allows setting the monitoring server IP and version (SNMPv1 Trap, SNMPv2 Trap, SNMPv2 Inform, SNMPv3 Trap, SNMPv3 Inform), and filling in the community string (can be understood as the transmission password of the SNMP protocol, the SNMP card and the connected monitoring platform should have consistent setting). After the above settings are completed, the alarm information of the SNMP card can be uploaded to the designated monitoring platform in real time, and the number of retries and retry interval can be set. After completing the settings, click [Submit] to confirm, as shown below:

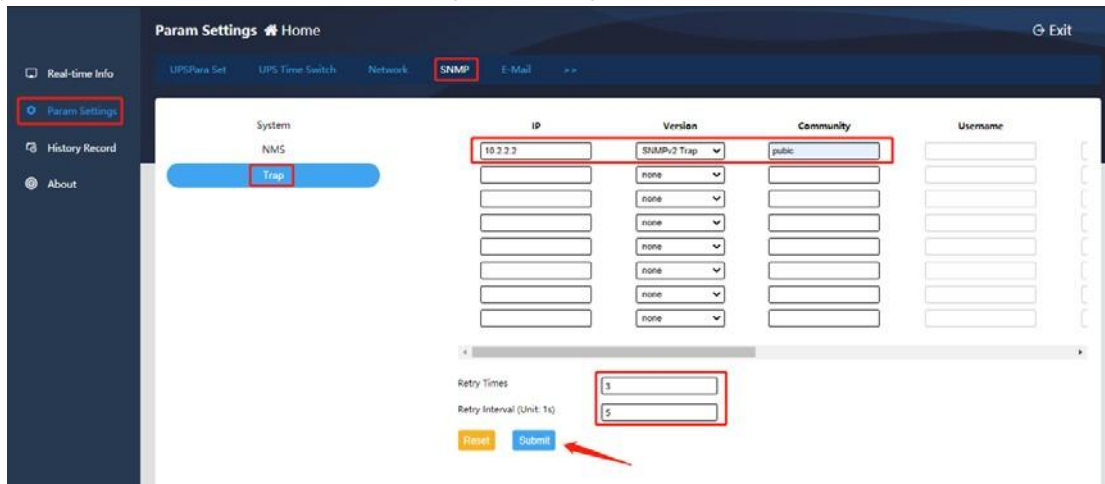

4.2.5. E-Mail Settings

A. Server Settings

This item needs to set the e-mail server address, server port number, sender address (same as the sending e-mail account), sending e-mail account and sending e-mail password. In addition, you can check whether the e-mail is encrypted and whether to send a test email. After completing the settings, click [Submit] to confirm, as shown below:

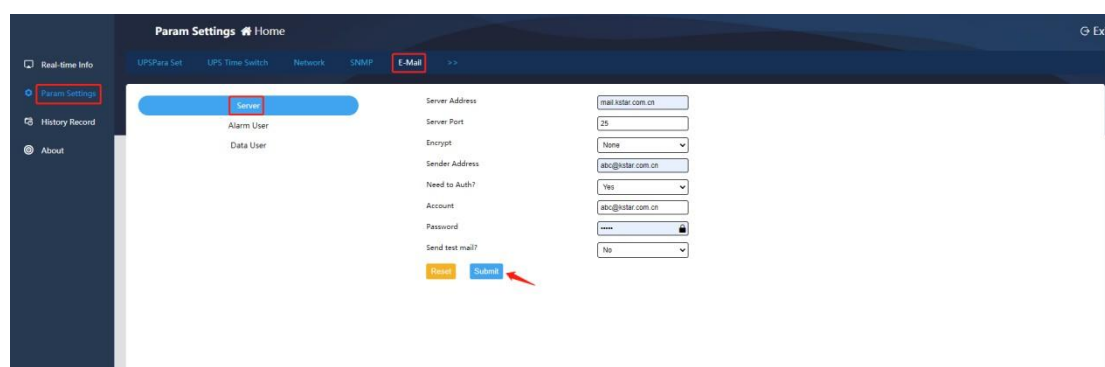
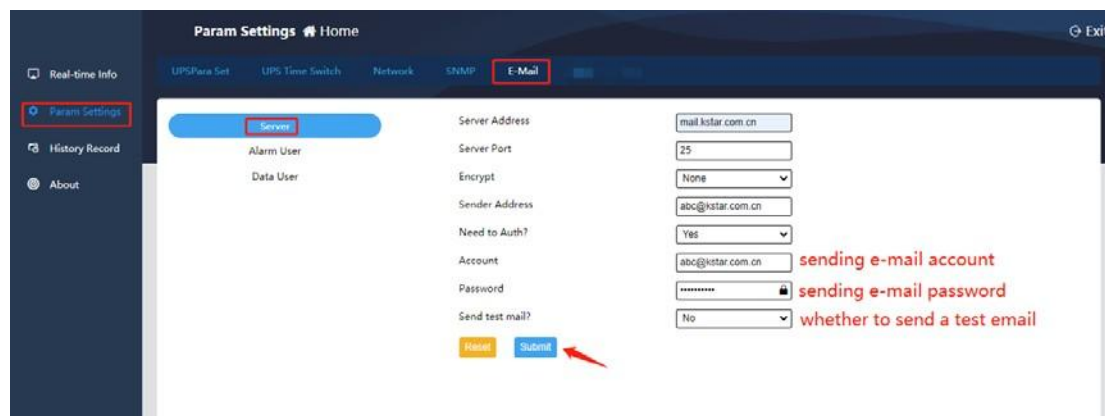

B. Alarm User Settings

This item needs to fill in the e-mail account that will receive the alarm email and select “Yes” for Enable to activate the e-mail alarm function. After completing the settings, click [Submit] to confirm, as shown below:

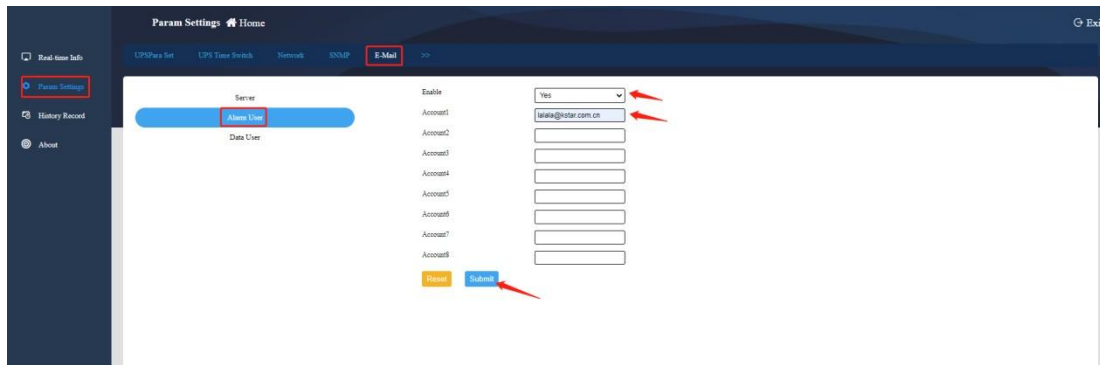

C. Data User Settings

This item is to regularly receive the operating history data of the previous day (00:00 to 23:59) of the device. Enable this function by selecting “Yes”, selecting the sending time, and filling in the e-mail account that receives the data. After completing the settings, click [Submit] to confirm, as shown below:

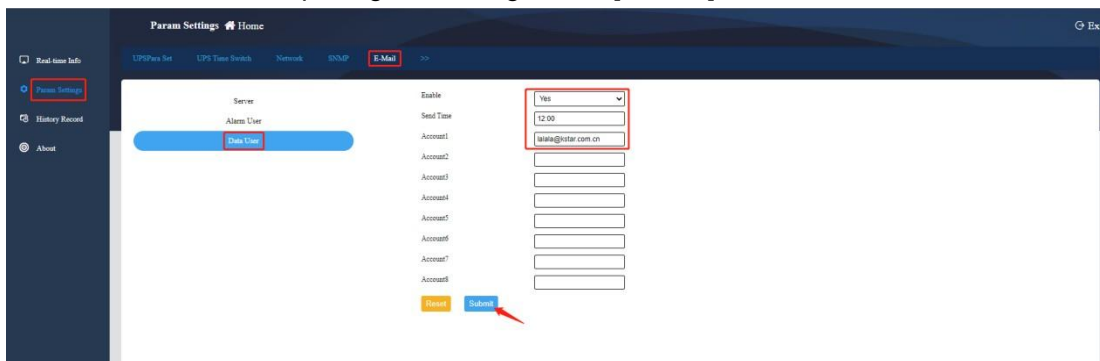

4.2.6. System Users

A. User Settings

This item allows adding users, filling in user name and password, and setting user permissions (read & write). After completing the settings, click [Submit] to confirm, as shown below:

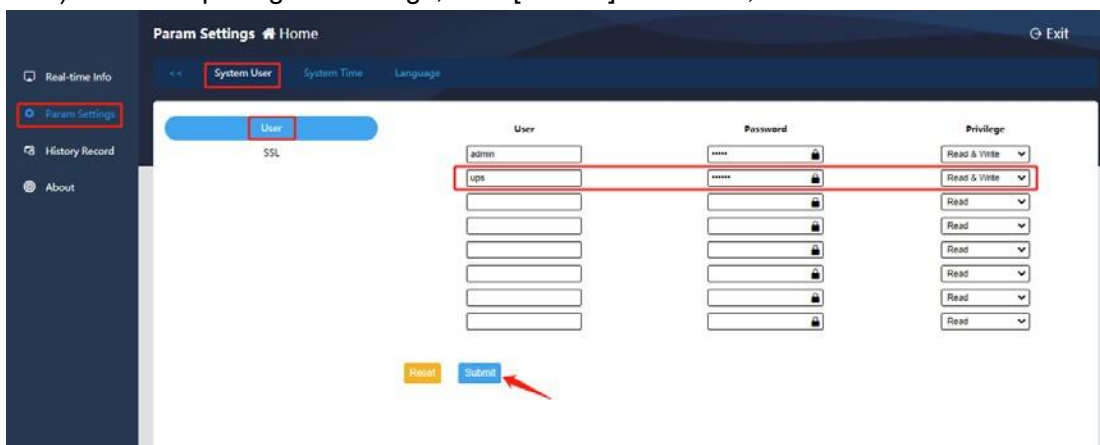

B. SSL Settings

This setting enables HTTPS access mode, and SSL public key and SSL certificate need to be uploaded.

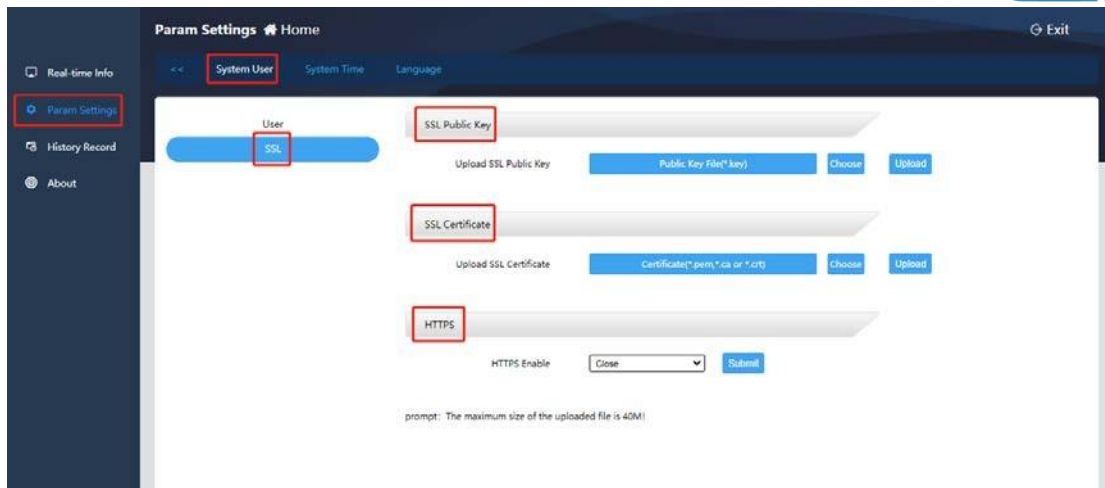

4.2.7. System Time

This item allows setting the system time and selecting the system restart method: ① Network time server settings: Fill in the time synchronization period, time server address, time zone, and click [Submit] to confirm;

② Manual setting: Click [Current PC Time], and then click [Submit] to manually synchronize the current computer time;

③ Automatic restart: Fill in the automatic restart period in minutes;

④ System restart: Click [Reboot] for 30 seconds to restart the device.

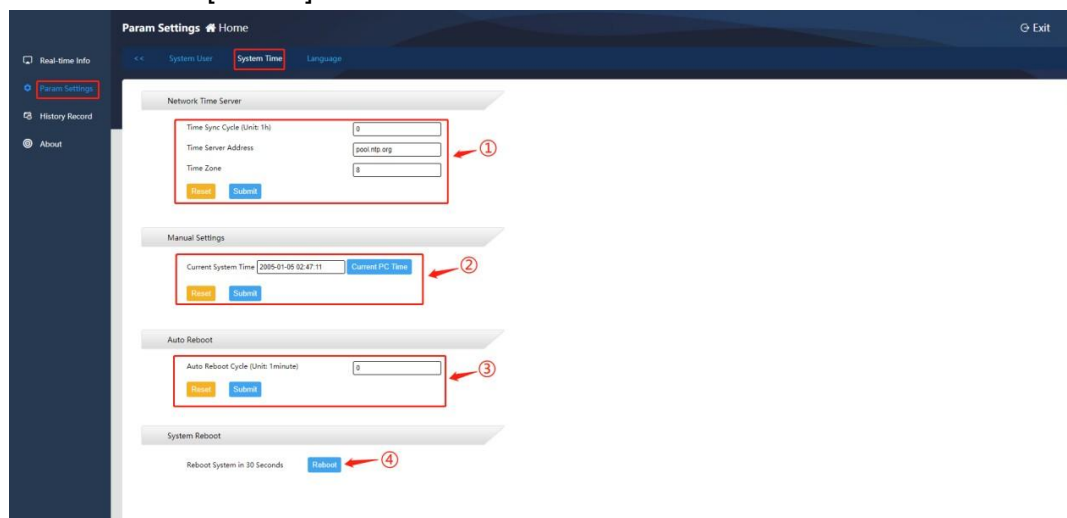

4.2.8. Language

This item allows setting the system language (Simplified Chinese/English) and the message language (Simplified Chinese/English). After completing the settings, click [Submit] to confirm, as shown below:



4.3. History

Historical record capacity: 60, 000 data logs (if the historical data recording interval is 1 minute, the historical data can be saved for 40 days), 5, 000 event logs and setting logs, and 10, 000 environmental logs.

4.3.1. Data Log

By filtering the time period, you can query the equipment running data log.

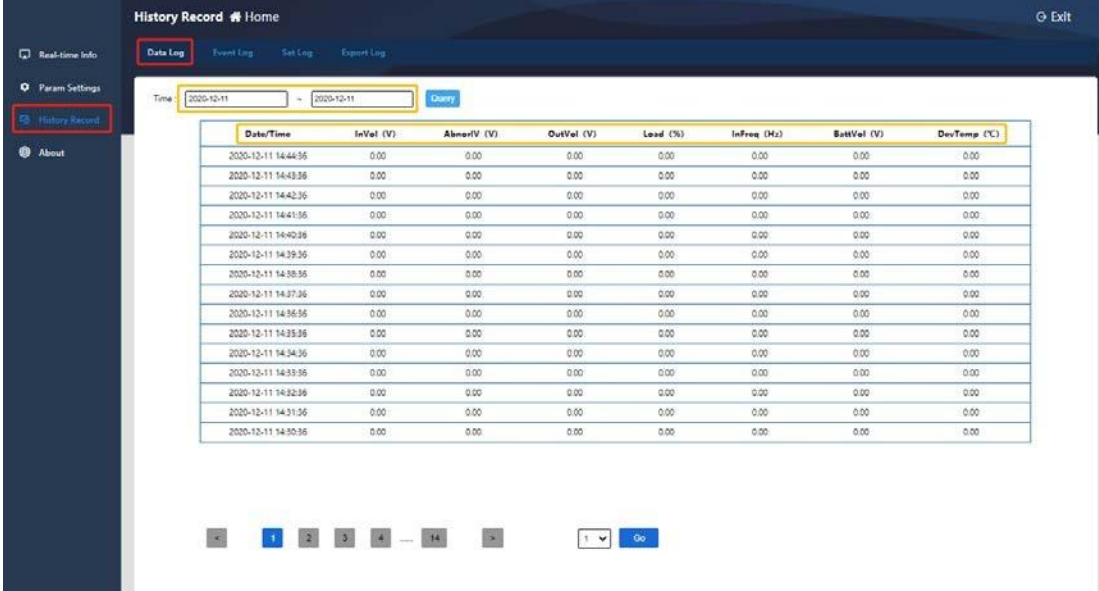

Date/Time	InVal (V)	AlarmV (V)	OutVal (V)	Load (%)	InFreq (Hz)	BattVal (V)	DevTemp (°C)
2020-12-11 14:44:36	0.00	0.00	0.00	0.00	0.00	0.00	0.00
2020-12-11 14:43:36	0.00	0.00	0.00	0.00	0.00	0.00	0.00
2020-12-11 14:42:36	0.00	0.00	0.00	0.00	0.00	0.00	0.00
2020-12-11 14:41:36	0.00	0.00	0.00	0.00	0.00	0.00	0.00
2020-12-11 14:40:36	0.00	0.00	0.00	0.00	0.00	0.00	0.00
2020-12-11 14:39:36	0.00	0.00	0.00	0.00	0.00	0.00	0.00
2020-12-11 14:38:36	0.00	0.00	0.00	0.00	0.00	0.00	0.00
2020-12-11 14:37:36	0.00	0.00	0.00	0.00	0.00	0.00	0.00
2020-12-11 14:36:36	0.00	0.00	0.00	0.00	0.00	0.00	0.00
2020-12-11 14:35:36	0.00	0.00	0.00	0.00	0.00	0.00	0.00
2020-12-11 14:34:36	0.00	0.00	0.00	0.00	0.00	0.00	0.00
2020-12-11 14:33:36	0.00	0.00	0.00	0.00	0.00	0.00	0.00
2020-12-11 14:32:36	0.00	0.00	0.00	0.00	0.00	0.00	0.00
2020-12-11 14:31:36	0.00	0.00	0.00	0.00	0.00	0.00	0.00
2020-12-11 14:30:36	0.00	0.00	0.00	0.00	0.00	0.00	0.00

4.3.2. Event Log

By filtering the time period, you can query the equipment event log.

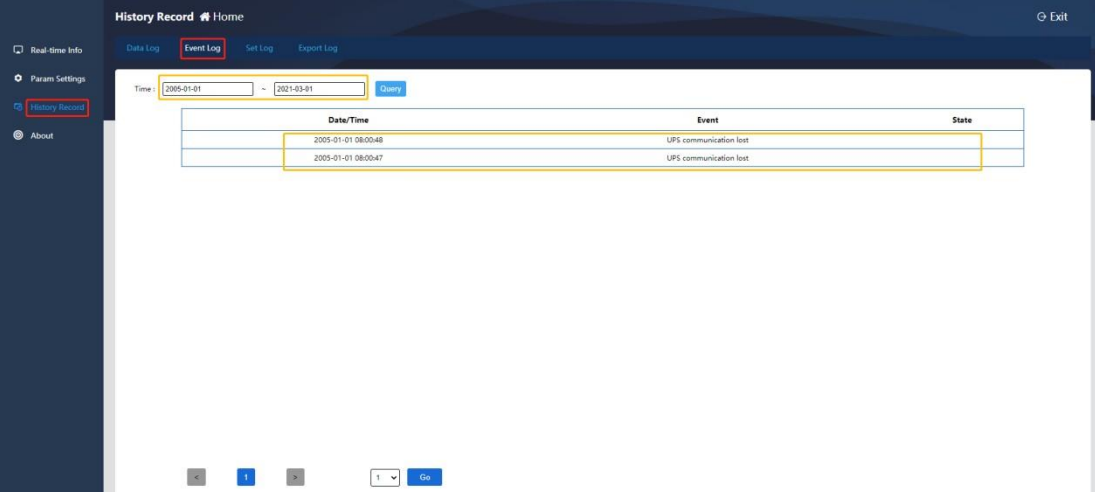

Date/Time	Event	State
2005-01-01 08:00:48	UPS communication lost	
2005-01-01 08:00:47	UPS communication lost	

4.3.3. Set Log

By filtering the time period, you can query the equipment setting log.

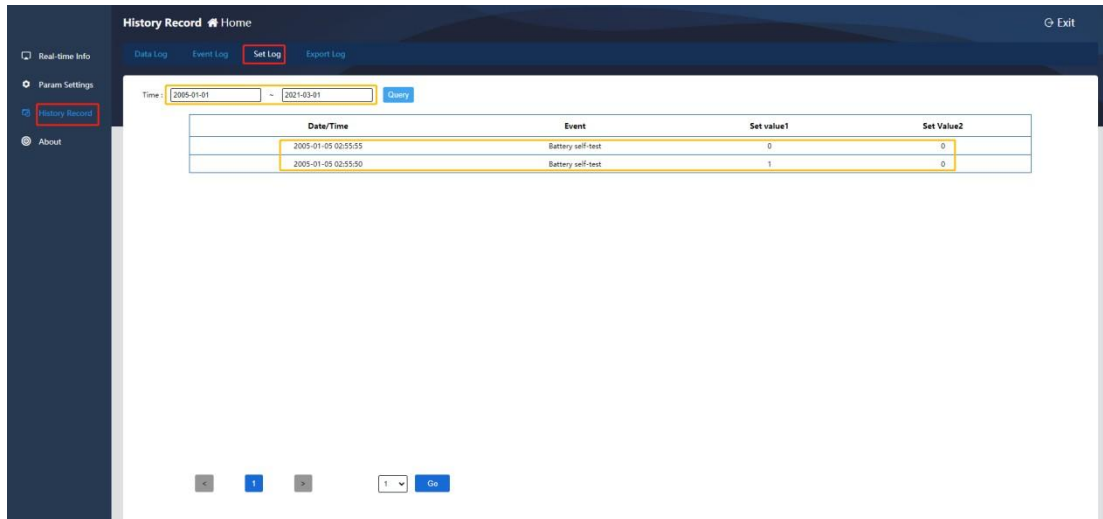

4.3.4. Export Log

By filtering the time period, select the log type to be exported, and click [Export] to download the log file in Excel format. After the download is successful, click [Close] to complete the log export.

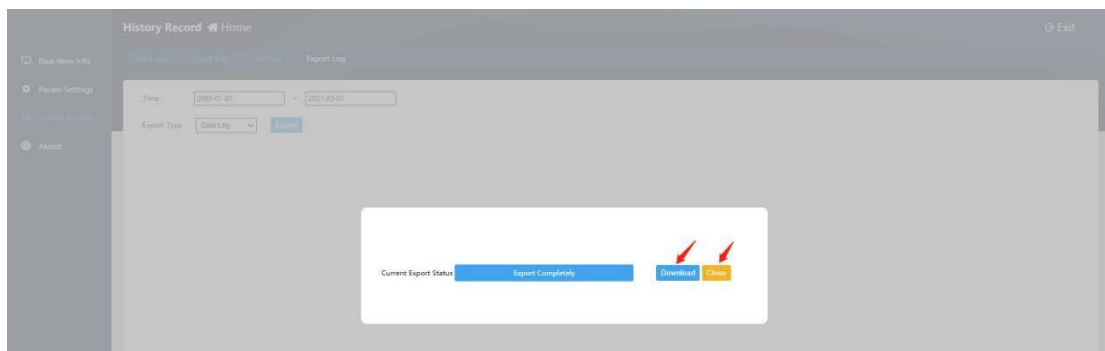
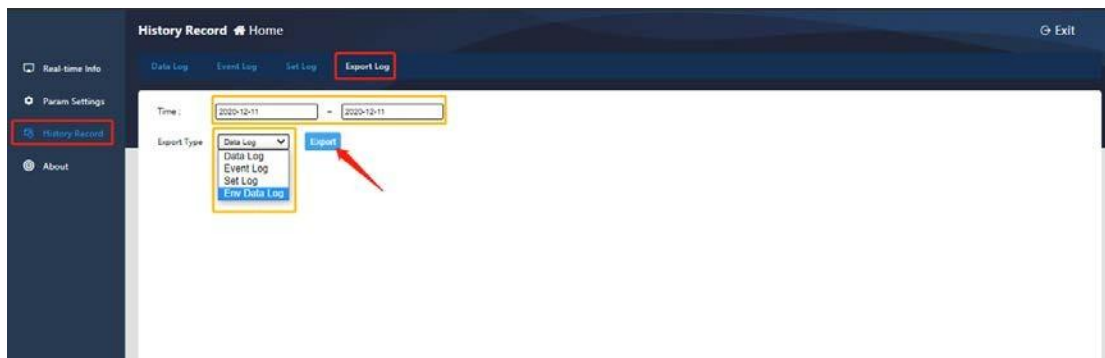

4.4. About

4.4.1. Web Page Upgrade

[System Information] allows viewing the current software version. When there is a version update, ① Click [Select]; ② Select the upgrade file named snmp-mini-2020xxxx-v1.0.x.bin; ③ Click [Upgrade]. It will prompt "File Upload Complete!"

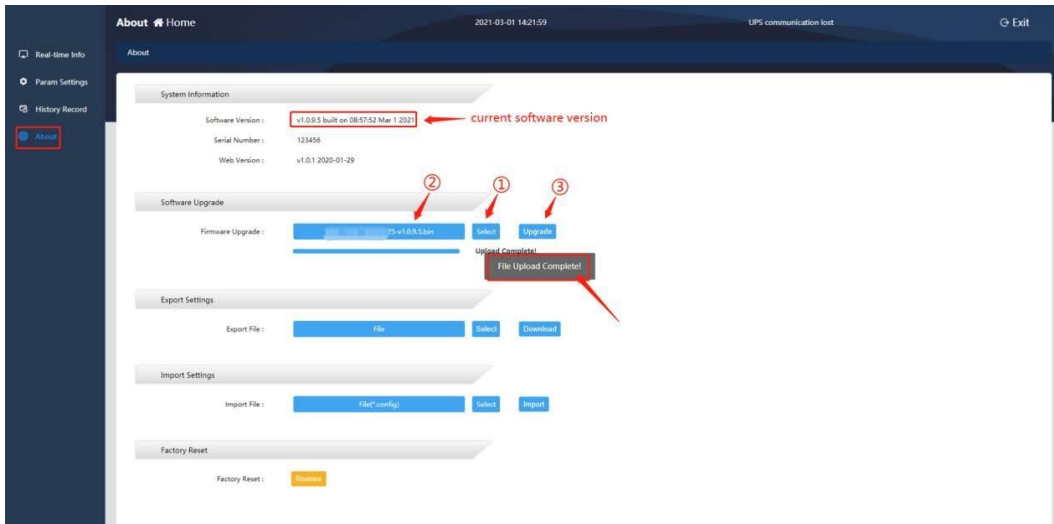

4.4.2. Export/Import Settings

Export settings file: Export a file containing all the configuration information of the current equipment (suffix format .config);

Import settings file: Import a file containing equipment configuration information (suffix format .config);

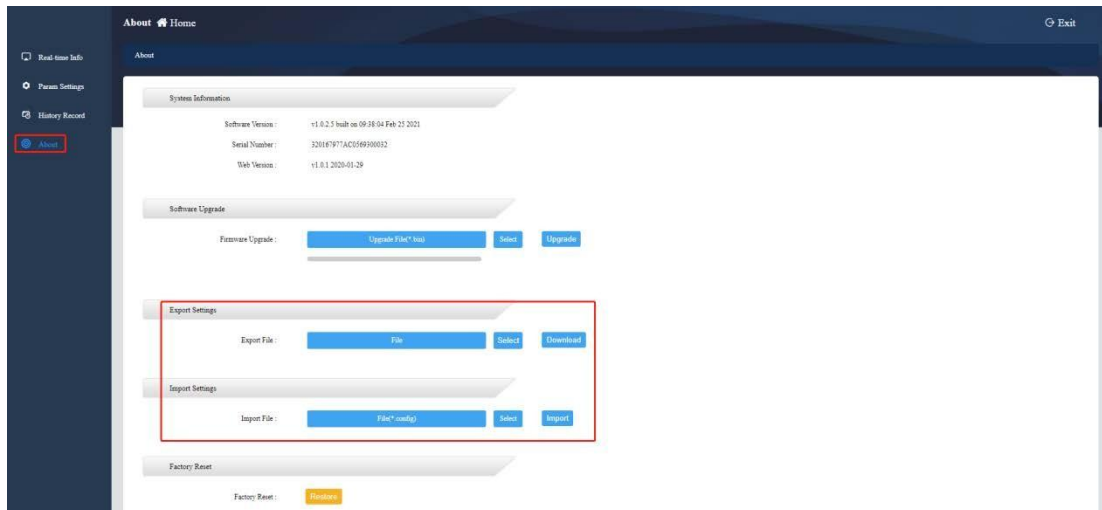

4.4.3. Reset

About -- Factory Reset, ① click [Restore], ② when a confirmation box pops up, click [Confirm] to restart the equipment and restore the factory settings.

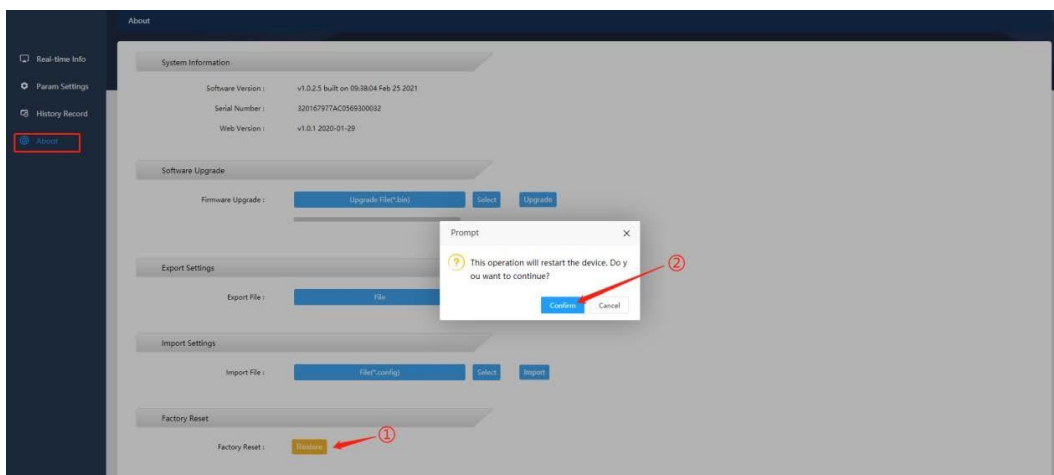

5. Shutdown Protection

Software--SNMP_Protector

SNMP_Protector is a shutdown protection software used with UPS and SNMP card. After installing SNMP_Protector on Windows, it will shutdown the computer when “Main circuit abnormal · battery low · ups abnormal shutdown ”occurs.

5.1. SNMP_Protector Installation

- ① Download the installation file from <http://download.ksdatacloud.com>, execute “SNMP_Protector_V1.xxx.exe” to install the SNMP_Protector;
- ② After installation, users can find “SNMP_Protector” in Windows “Start”, click “protector” to start.

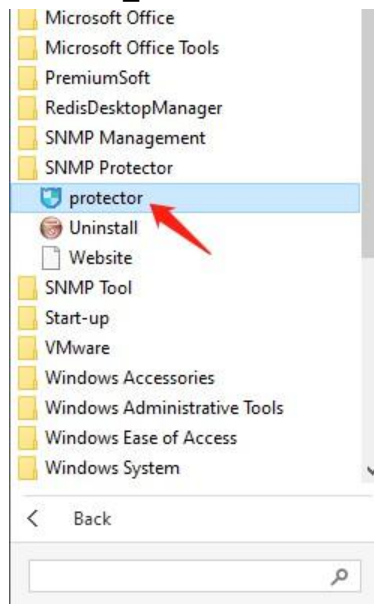

5.2. SNMP_Protector Usage

The software interface is mainly divided into three parts: ① Menu setting bar, ② Device list, ③ Alarm information list; as shown below:

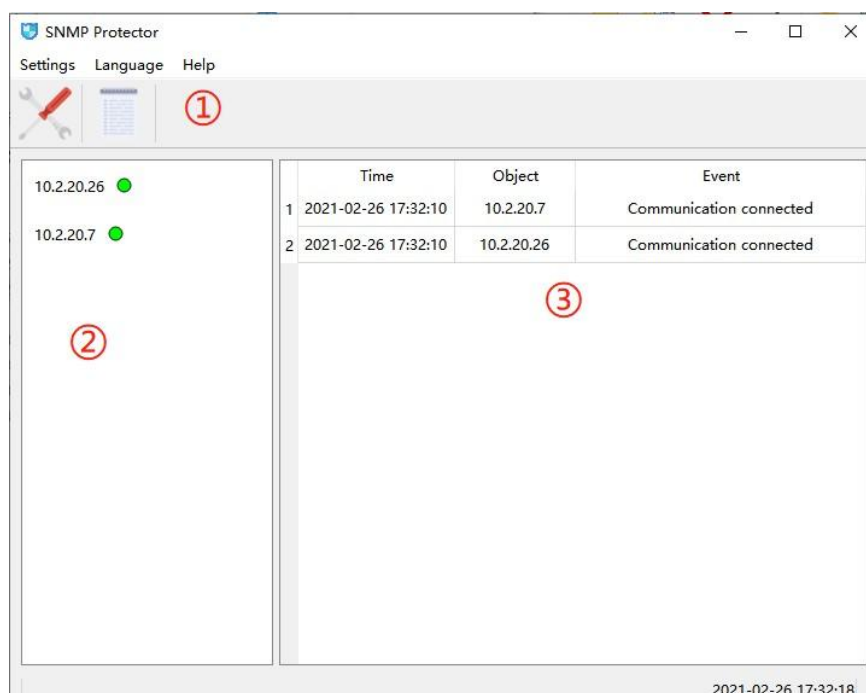

A. Language Setting

The default language is English, users can, ① Click [Language], ② Select the interface language type as English or Chinese.

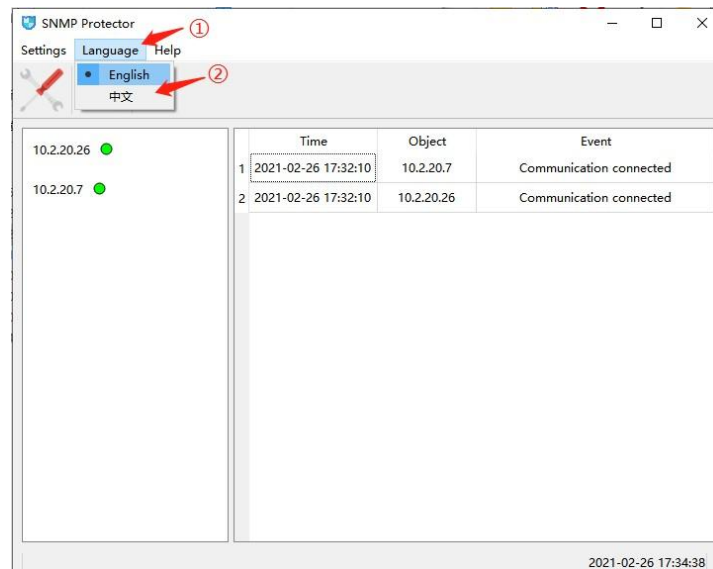

B. Host Addition

① Click Setting icon, ② Click [Add], ③ Select SNMP v1/v2(default), ④ Fill in the host(SNMP card)IP address, ⑤ Click [Sure] to complete the device addition.

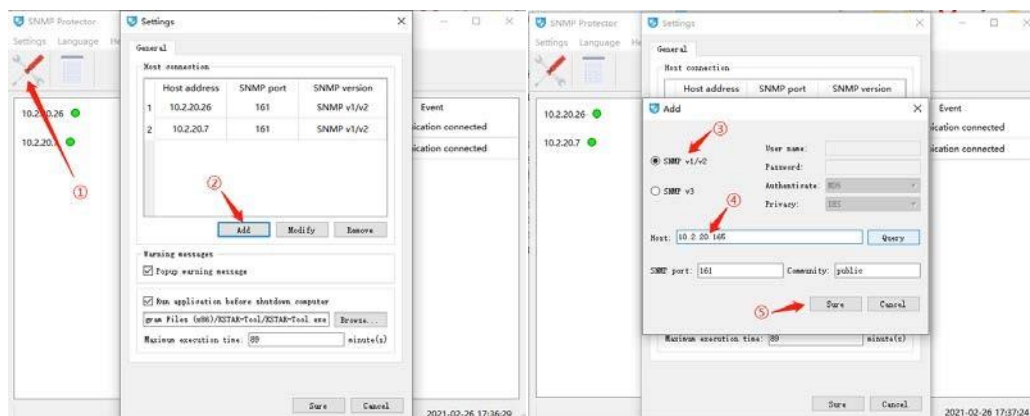

C. Log Query and Export

① Click Log icon, ② Select the query time, click [Read], ③ Display the query results, ④ Click [Save as] to Excel file.

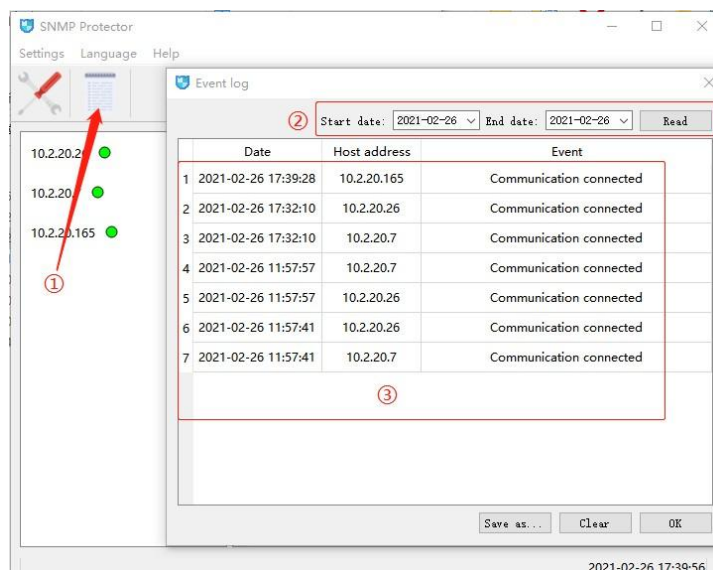

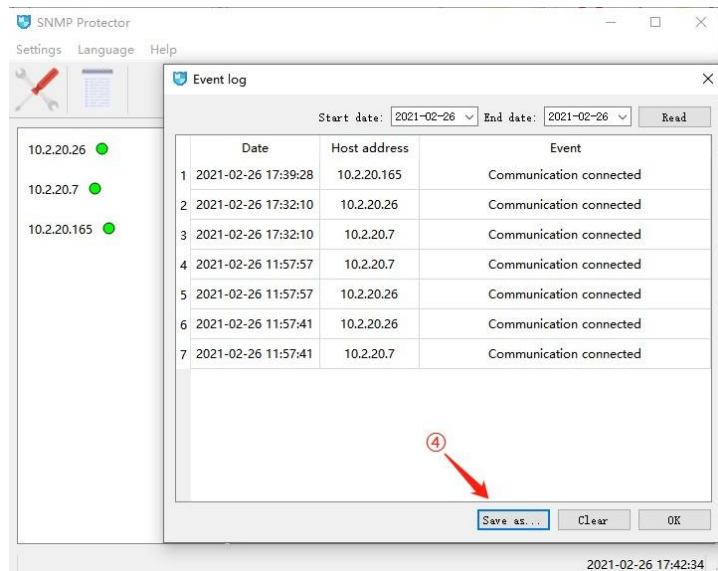

D. Version Information

Click [Help]--[About], software version will be shown in the pop-up window.

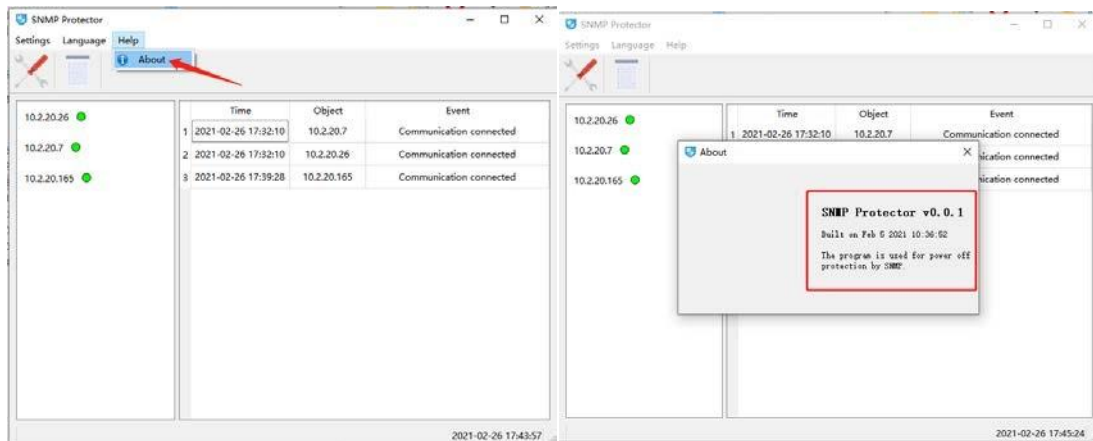

6. Centralized Monitoring Software-- SNMP Management

SNMP Management is a software for batch unified management of SNMP devices. After adding SNMP devices, the software can record the running data and configuration of the UPS, and can perform remote control such as shutdown and self-checking of the UPS.

6.1. SNMP Management

- ① Download installation file from <http://download.ksdatacloud.com>, execute "SNMP_Management_20xxxxxx_V1.xxxxx.exe";
- ② After installation, users can find "SNMP_Management" in Windows "Start", click "SNMP Management" to start.

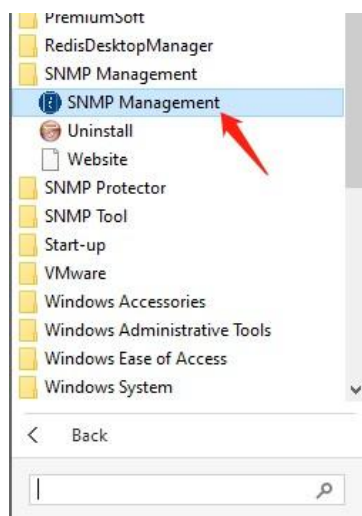

6.2. SNMP Management Usage

The software interface is mainly divided into three parts: ① Menu bar, ② Management station ③ Main data interface, as shown in the figure:

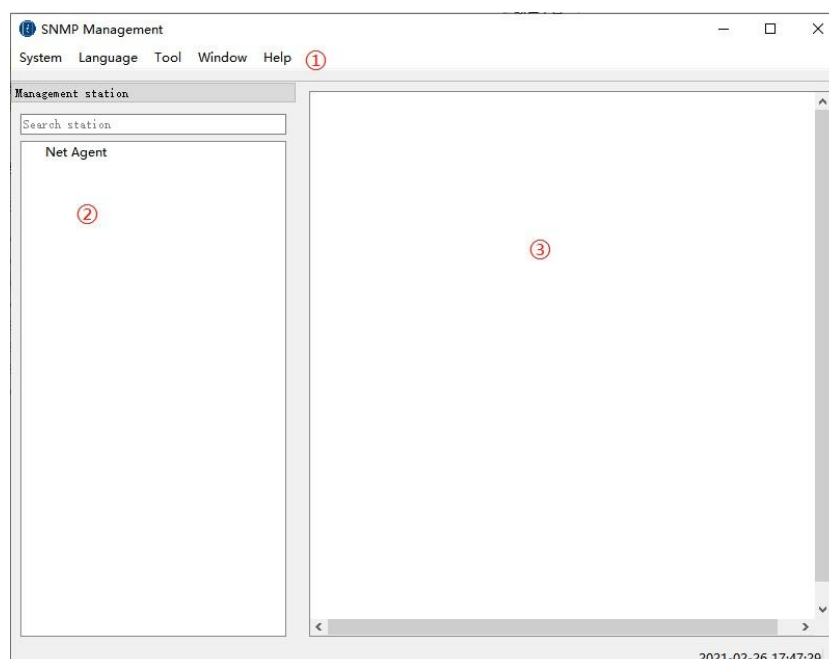

A. Language Setting

The default language of the software is English, and the user can choose from the menu bar, "Language", to select the language type displayed on the interface.

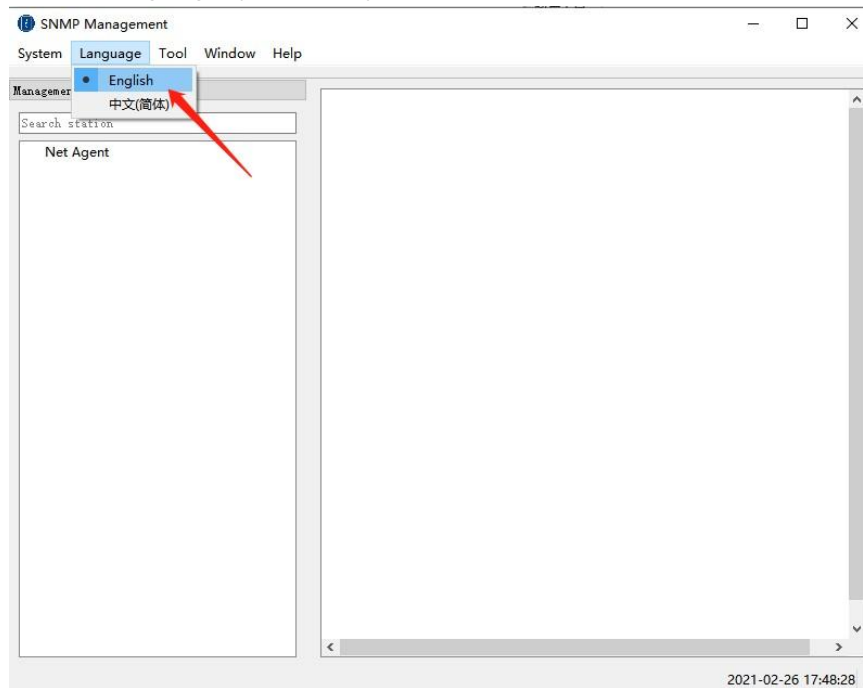

B. System Setting

System settings are used to set the communication parameters of the software and SNMP devices:

- SNMP Version: SNMP protocol version, this software supports SNMP v1 and SNMP v2c;
- Polling cycle: Cycle of software polling device data;
- Polling timeout: Timeout of polling single device;
- Store data cycle: Cycle of storing device data;
- Polling retry: Number of retries after polling failed.

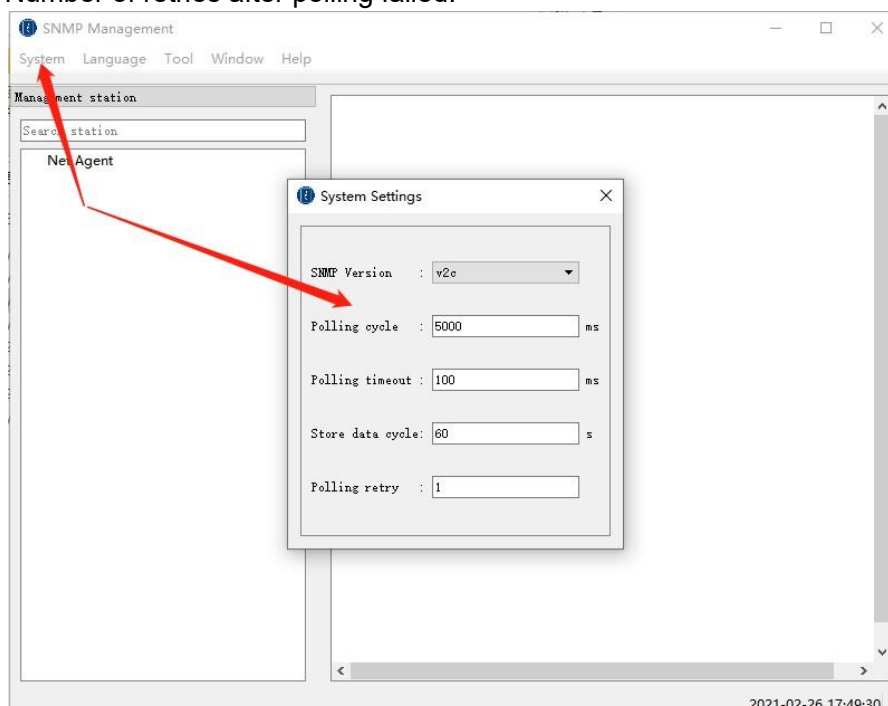

C. Station Addition

When using, firstly need to add the corresponding station in the Net Agent category:

right-click the Net Agent item on the left side of the interface, select "Add", after completing the station name, click the "Sure" to complete the addition of the main station;

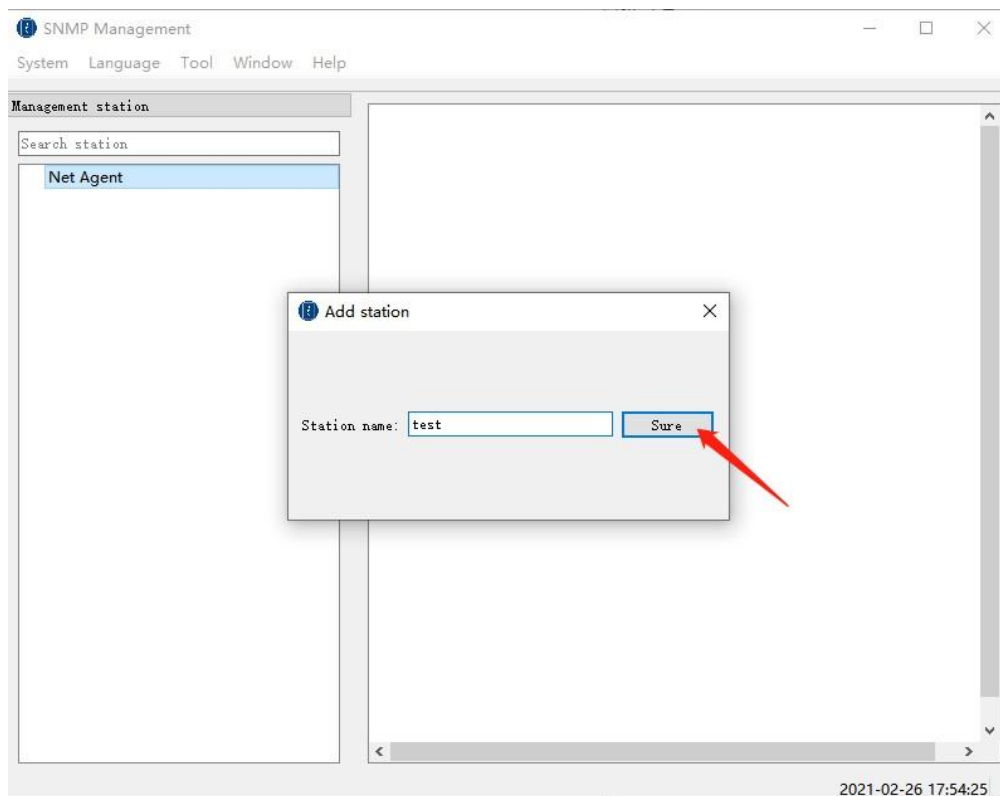
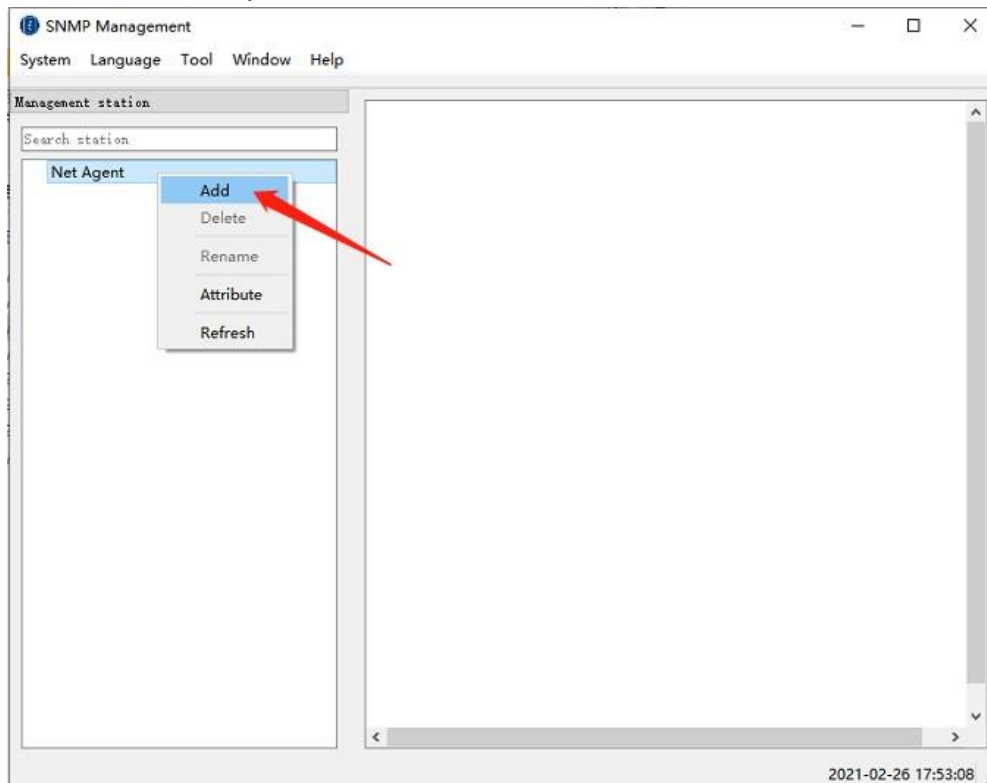

D. Device Addition

After completing the addition of the master station, you need to add the device under the corresponding station, click the name of the added station, right-click on the device data interface on the right, and then select "Add", the software will pop up the device addition interface, fill in. Then, click "Sure", the device will be added to the corresponding station, and the software can monitor the device in real time.

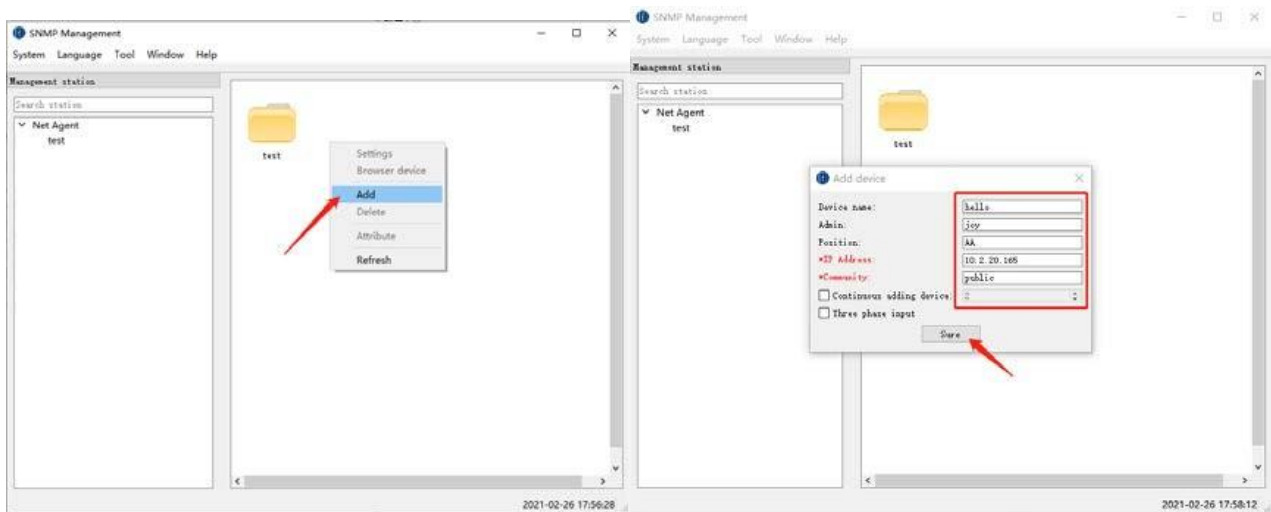

E. Device Panel

Click "Window--Device panel" to open the data panel, select the device to view the related data;

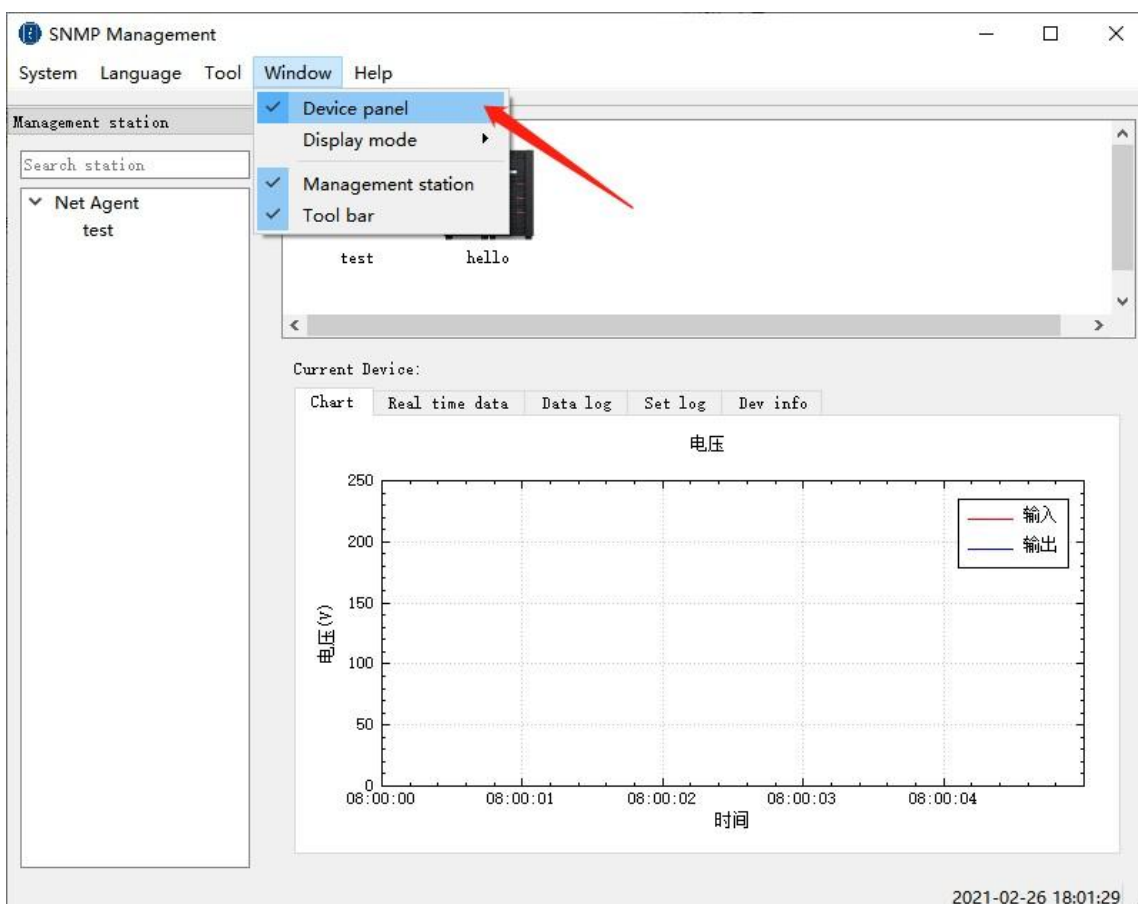

- ① Chart: Display the dynamic curve diagram of the input and output voltage of the device, and can visually observe the changes of input and output voltage in real time.

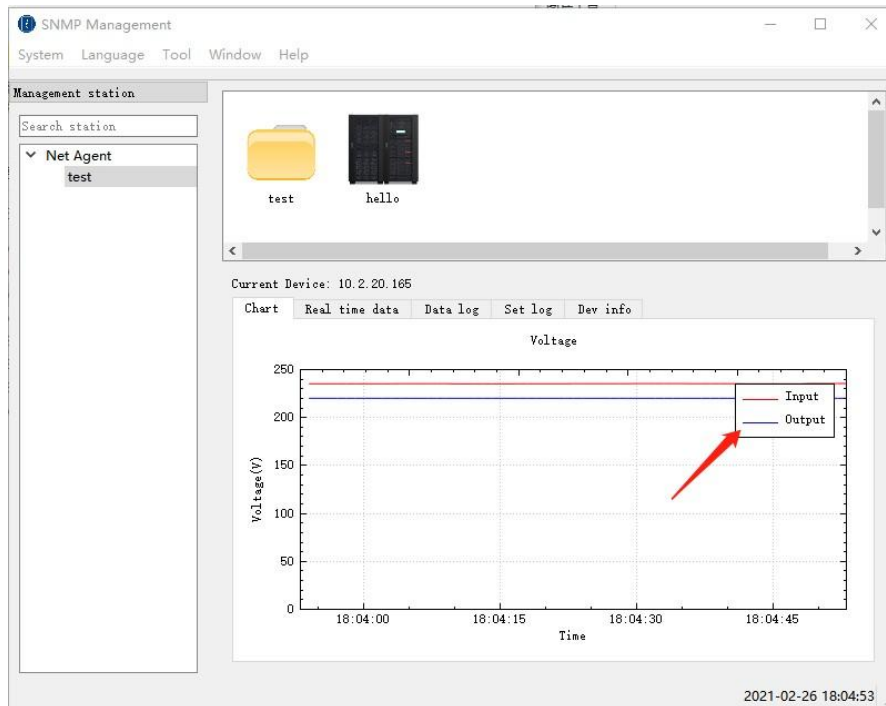

- ② Real time data: Display specific data of battery, input and output information of the device.

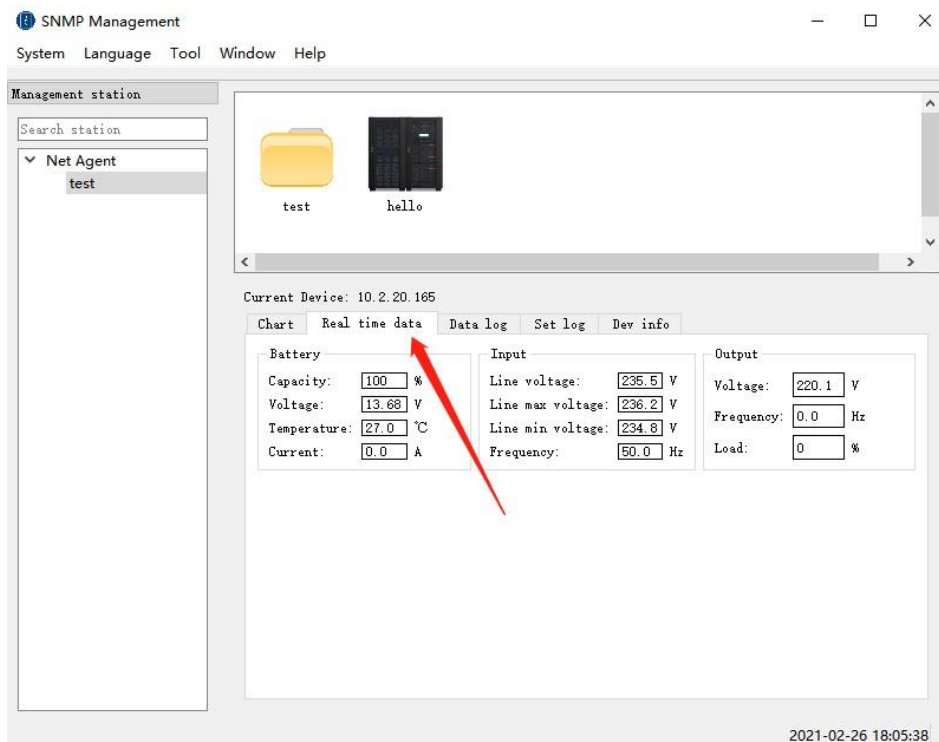

- ③ Data log: Users can choose to read the data records within the time range by themselves. First select the start date and end date of the data record to be queried, and then click the "Sure" button to query the data records within the selected date range. The software supports exporting data records to various types of Excel files. Click the "Export" button to export the currently read data records. Click the "Clear Logs" button to clear all data records of the currently selected device.

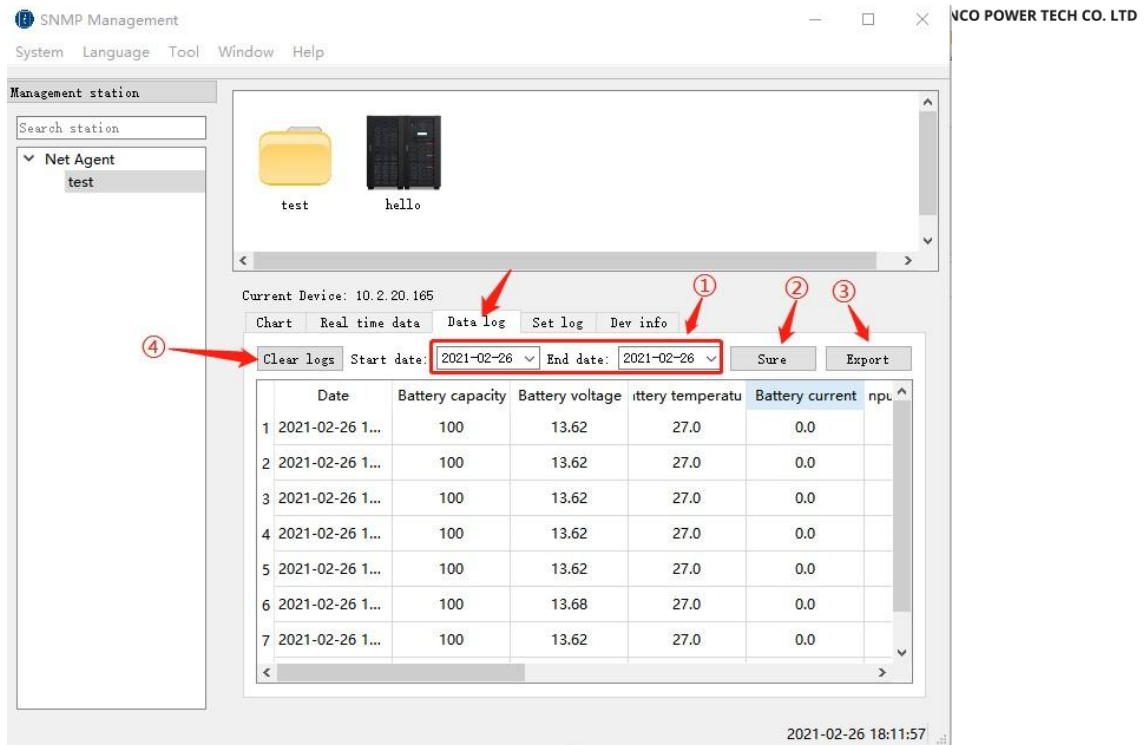

- ④ Set log: Record software settings record.
- ⑤ Dev info: Display current device information log connected to SNMP card.
 - Model: Device model connected to SNMP card;
 - Name: Device name connected to SNMP card;
 - UPS firmware version: UPS connected to SNMP card;
 - Date of manufacture: Device's date of manufacture;
 - Serial number: Device's manufacture serial number;
 - Agent firmware version: Agent version number of SNMP card.

F. Version Information

Click [Help]--[About], can view the software version information in the pop-up window, including software name, version number, build date of the program, copyright attribution and application introduction.

