



User Manual

TM33E 50-200 kVA

Solutions behind the power

All rights reserved.

The information in this document is subject to change without notice.

Publish statement

Thank you for purchasing this series UPS.

This series UPS is an intelligent, single phase in single phase out, high frequency online UPS designed by our R&D team who is with years of designing experiences on UPS. With excellent electrical performance, perfect intelligent monitoring and network functions, smart appearance, complying with EMC and safety standards, The UPS meets the world' s advanced level.

Read this manual carefully before installation

This manual provides technical support to the operator of the equipment.

3:3



Contents

| | |
|---|----|
| 1. Safety | 2 |
| 1.1 Safety notes | 2 |
| 1.2 Symbols used in this guide | 2 |
| 2. Main Features | 3 |
| 2.1 Summarization | 3 |
| 2.2 Functions and Features | 3 |
| 3. Installation | 4 |
| 3.1 Unpacking and checking | 4 |
| 3.2 Cabinet Outlook | 5 |
| 3.3 LCD control panel | 9 |
| 3.4 Installation notes | 9 |
| 3.5 External Protective Devices | 10 |
| 3.6 Power Cables | 10 |
| 3.7 Power cable connect | 13 |
| 3.8 Battery connection | 17 |
| 3.9 UPS parallel Installation | 18 |
| 3.10 LBS installation | 20 |
| 3.11 Computer access | 21 |
| 4. Operation | 23 |
| 4.1 Operation Modes | 23 |
| 4.2 Turn on/off UPS | 25 |
| 4.3 The LCD Display | 29 |
| 4.4 Display Messages/Troubleshooting | 55 |
| 4.5 Options | 57 |
| Appendix 1 Specifications | 59 |
| Appendix 2 Problems and Solution | 61 |
| Appendix 3 USB communication port definition | 62 |
| Appendix 4 RS232 communication port definition | 63 |
| Appendix 5 RS485 communication port definition | 64 |
| Appendix 6 Optional port definition | 65 |
| Appendix 7 REPO instruction | 65 |

1. Safety

Important safety instructions - Save these instructions

There exists dangerous voltage and high temperature inside the UPS. During the installation, operation and maintenance, please abide the local safety instructions and relative laws, otherwise it will result in personnel injury or equipment damage. Safety instructions in this manual act as a supplementary for the local safety instructions. Our company will not assume the liability that caused by disobeying safety instructions.

1.1 Safety notes

1. Even no connection with utility power, 220/230/240VAC voltage may still exist at UPS terminal!
2. For the sake of human being safety, please well earth the UPS before starting it.
3. Don't open or damage battery, for the liquid spilled from the battery is strongly poisonous and do harmful to body!
4. Please avoid short circuit between anode and cathode of battery, otherwise, it will cause spark or fire!
5. Don't disassemble the UPS cover, or there may be an electric shock!
6. Check if there exists high voltage before touching the battery
7. Working environment and storage way will affect the lifetime and reliability of the UPS. Avoid the UPS from working under following environment for long time
 - ◆ Area where the humidity and temperature is out of the specified range(temperature 0 to 40°C, relative humidity 5%-95%)
 - ◆ Direct sunlight or location nearby heat
 - ◆ Vibration Area with possibility to get the UPS crashed.
 - ◆ Area with erosive gas, flammable gas, excessive dust, etc
8. Keep ventilations in good conditions otherwise the components inside the UPS will be over-heated which may affect the life of the UPS.

1.2 Symbols used in this guide



WARNING!

Risk of electric shock



CAUTION!

Read this information to avoid equipment damage

2. Main Features

2.1 Summarization

This series UPS is a kind of three-in-three-out high frequency online UPS.

The UPS can solve most of the power supply problems, such as blackout, over-voltage, under-voltage, voltage sudden drop, oscillating of decreasing extent, high voltage pulse, voltage fluctuation, surge, inrush current, harmonic distortion (THD), noise interference, frequency fluctuation, etc..

This UPS can be applied to different applications from computer device, automatic equipment, communication system to industry equipment.

2.2 Functions and Features

◆Integrated solution for data center

UPS can be integrated with battery cabinet, PDU external maintenance bypass, offering excellent choice for data center.

◆3Phase In/3Phase Out UPS

It is 3Phase In/3Phase Out high-density UPS system, of which input current is kept in balance. No unbalance problem might occur.

◆Digital Control

This series UPS is controlled by Digital Signal Processor (DSP); enhance, it increases reliability, performance, self-protection, and self-diagnostics and so on.

◆Battery Configurable

From 30 blocks to 50 blocks, the battery voltage of this series UPS can be configured at 30 blocks, 32 blocks, 34 blocks, 36 blocks, 38 blocks, 40 blocks, 42 blocks, 44 blocks, 46 blocks, 48 blocks or 50 blocks according to your convenience.

◆Charging Current is configurable

Via setting tool, the user may set the capacity of the batteries as well as reasonable charging current as well as maximum charging current. Constant voltage mode, constant current mode or floating mode can be switched automatically and smoothly.

◆Intelligent Charging Method

The series UPS adopts advanced three-stage charging method—

1st stage: high current constant current charging

to guarantee to charge back to 90%;

2nd-stage: Constant Voltage

In order to vitalize battery and make sure batteries are fully charged

3rd stage: floating mode.

With this 3-stage charging method, it extends the life of the batteries and guarantees fast charging.

◆LCD Display

With LCD plus LED displays, the user may easily get UPS status and its operational parameters, such as input/output voltage, frequency & load%, battery % and ambient temperature, etc...

◆Intelligent Monitoring Function

Via optional SNMP Card, you may remotely control and monitor the UPS.

◆EPO Function

The series UPS may be completely shut off when the EPO is pressed. REPO function (Remote EPO) is also available in this series UPS.

3. Installation

3.1 Unpacking and checking



Don't lean the UPS when moving it out from the packaging

Procedure

Step 1 Use a pallet truck to transport the UPS to the installation position.

Step 2 Check the UPS packing.

Step 3 Hold the sliding plate steady. Cut and remove the binding tapes.

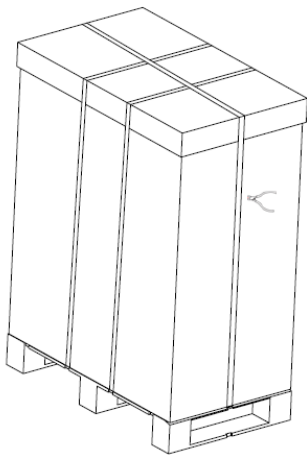

Step 5 Remove the plastic bag and take out the fittings box.

Step 6 Check that the UPS is intact.

1. Visually inspect the UPS appearance for shipping damage. If it is damaged, notify the carrier immediately.
2. Check the accessories according to the packing list and contact the dealer in case of missing parts.

Step 7 Remove the front panel and rear panel to remove the L-shaped bracket that secures the cabinet and the pallet, and secure the sliding

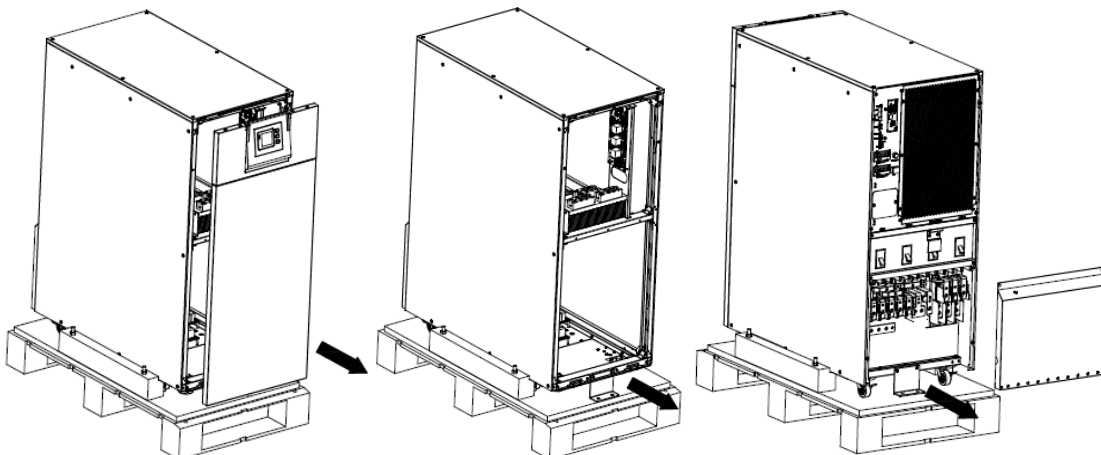

Step 8 Remove the front panel and rear panel to remove the L-shaped bracket and the plates at the left and right side of the UPS that secures the cabinet and the pallet, and secure the sliding

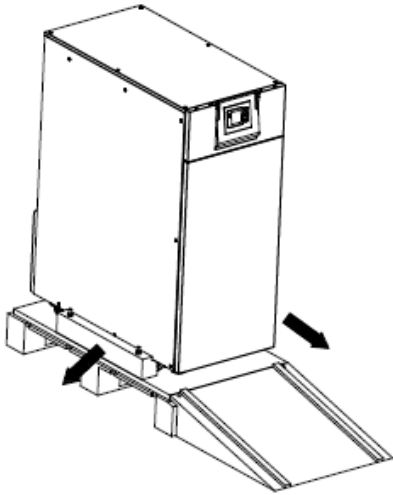

3.2 Cabinet Outlook

50kVA &60kVA

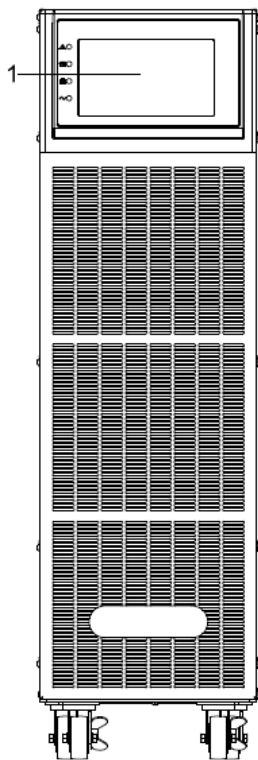

Front View

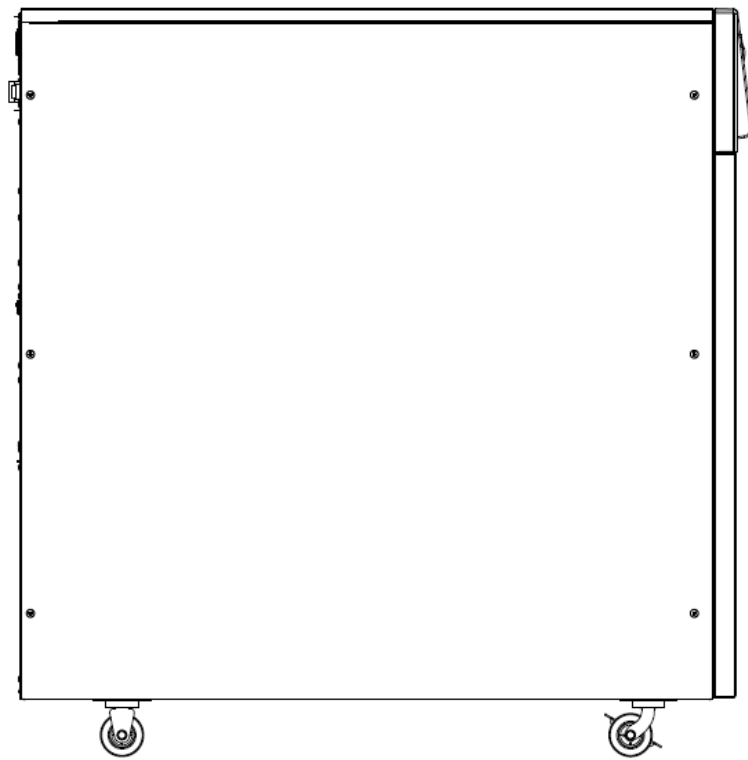

Side View

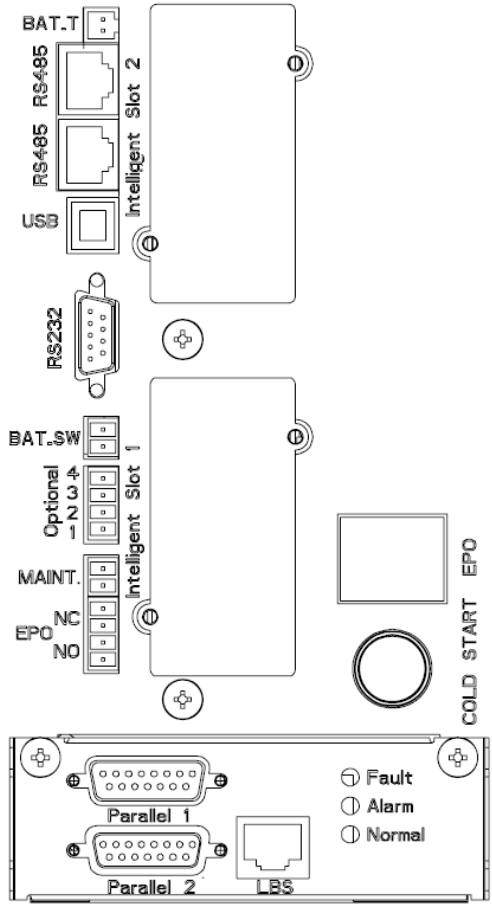
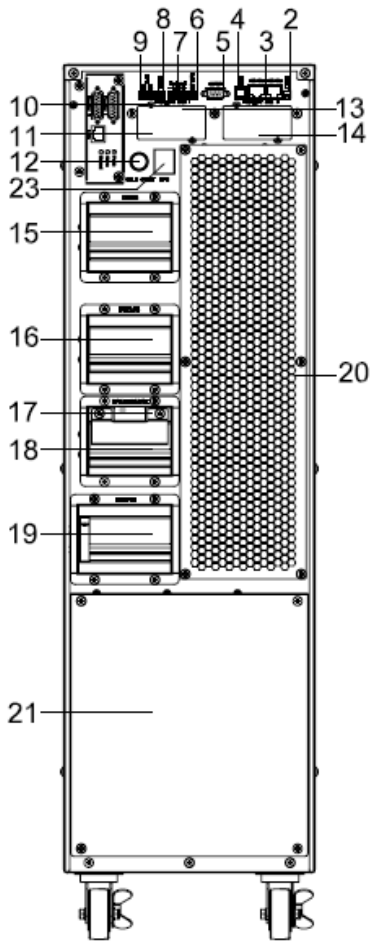

Rear View

80kVA-160kVA

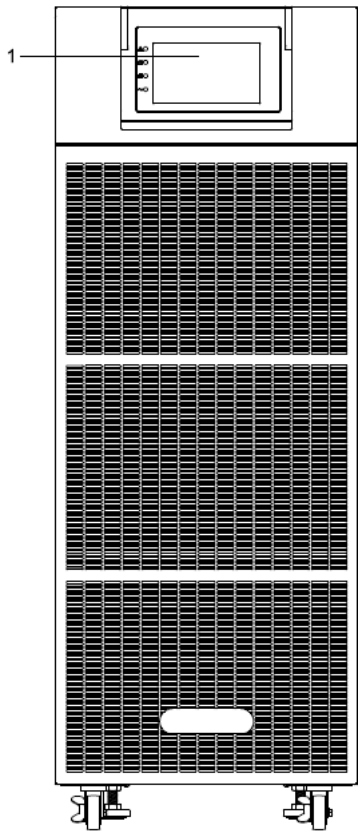

Front View

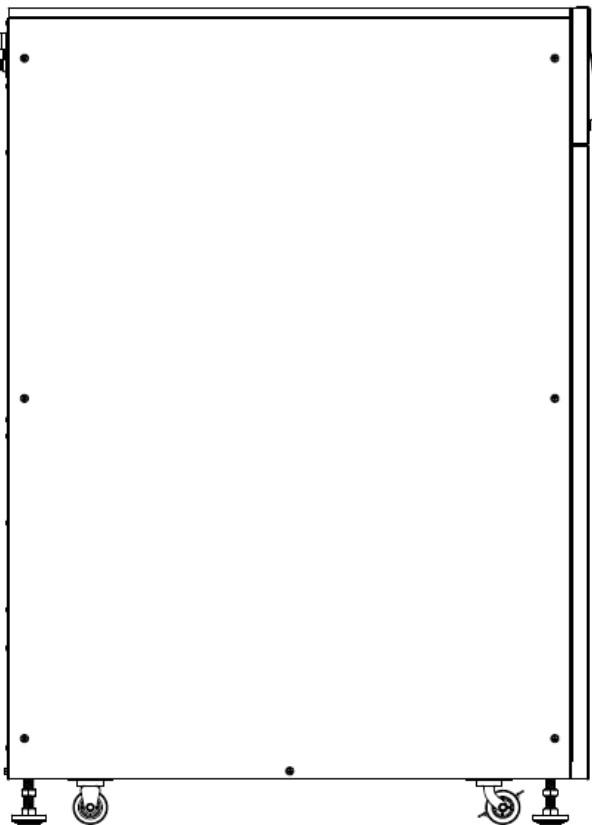

Side View

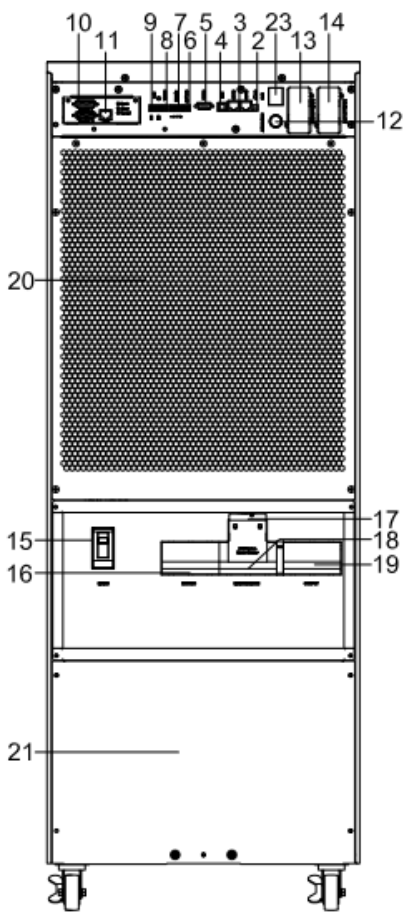

80kVA

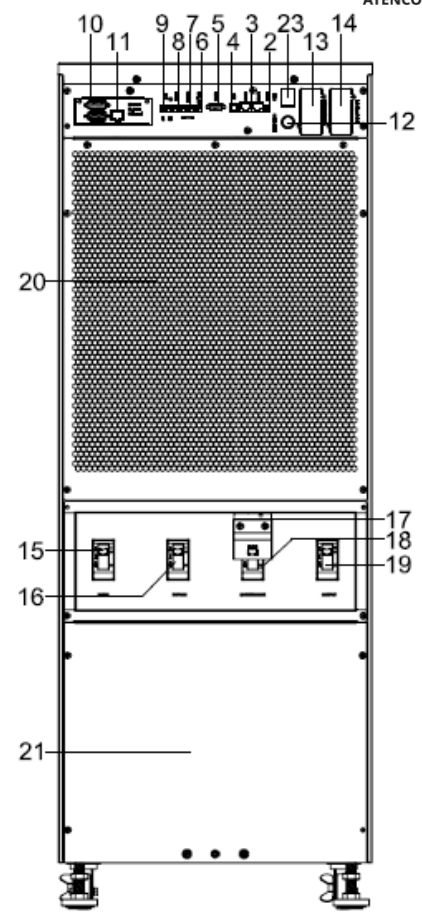

100-160kVA

Rear View

180-200kVA

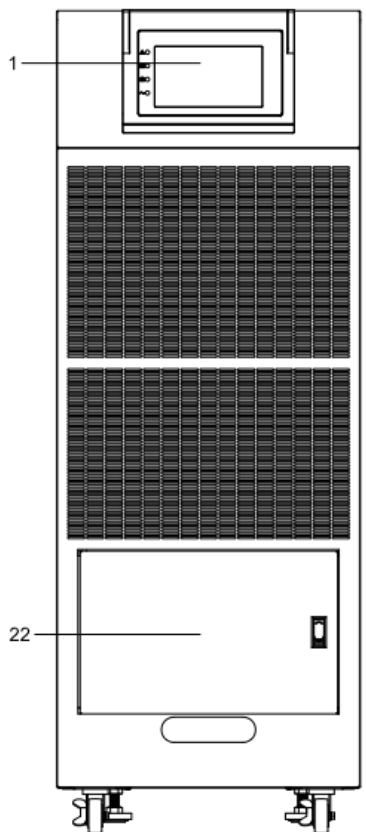

Front View

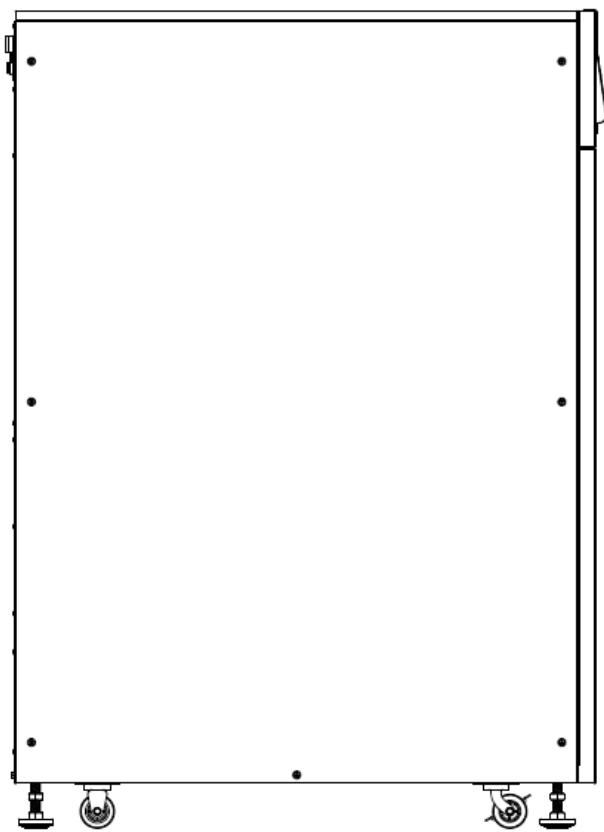

Side View

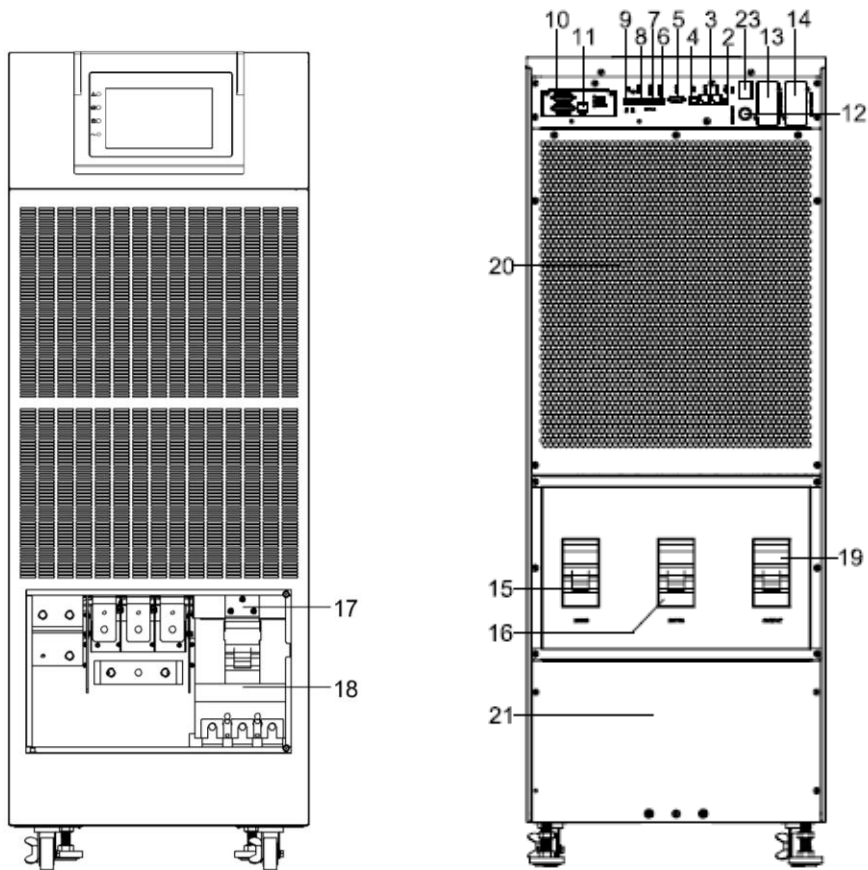

Rear View

Monitor panel

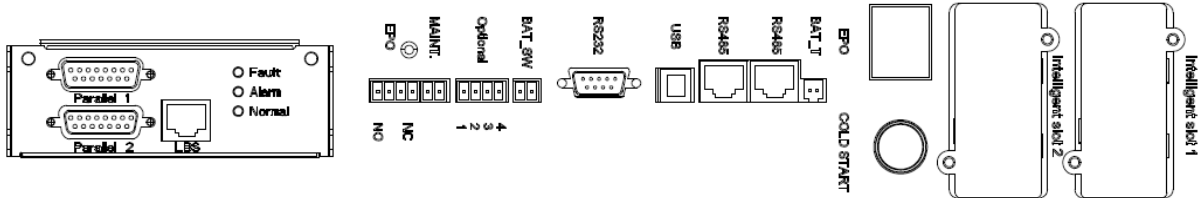

| | |
|--|--|
| (1) LCD panel | (2) Temperature sensor port (for NTC) |
| (3) RS485 port (for RS485 temperature sensor) | (4) USB port |
| (5) RS232 | (6) BAT_SW : detect battery switch status |
| (7) Optional port (Port for Backfeed protection, or for battery breaker driver to prevent battery over-drain after UPS shuts down) | (8) MAINTAIN-AUXSWS port |
| (9) REPO port | (10) Parallel port |
| (11) LBS port | (12) Cold-start |
| (13) Intelligent Slot 1 (SNMP card/ Relay card) | (14) Intelligent Slot 2 (SNMP card/ Relay card) |
| (15) Mains breaker | (16) Bypass breaker |
| (17) Maintenance breaker cover | (18) Maintenance breaker |
| (19) Output breaker | (20) Cover for UPS Maintenance |
| (21) Cabling terminal cover | (22) Maintenance breaker and battery terminal door(200K) |
| (23) EPO key | |

3.3 LCD control panel



LCD control panel introduction

(1) LED (from top to bottom: “Fault”, “bypass”, “battery”, “inverter”)

(2) LCD display

3.4 Installation notes

Note: Consider for the convenience of operation and maintenance, the space in front and back of the cabinet should be left at least 100cm and 80cm respectively when installing the cabinet.

◆ Please place the UPS in a clean, stable environment, avoid the vibration, dust, humidity, flammable gas and liquid, corrosive. To avoid from high room temperature, a system of room extractor fans is recommended to be installed. Optional air filters are available if the UPS operates in a dusty environment.

◆ The environment temperature around UPS should keep in a range of 0°C ~ 40°C. If the environment temperature exceeds 40°C, the rated load capacity should be reduced by 12% per 5°C. The max temperature can't be higher than 50°C.

◆ If the UPS is dismantled under low temperature, it might be in a condensing condition. The UPS can't be installed unless the internal and external of the equipment is fully dry. Otherwise, there will be in danger of electric shock.

◆ Batteries should be mounted in an environment where the temperature is within the required specs. Temperature is a major factor in determining battery life and capacity. In a normal installation, the battery temperature is maintained between 15°C and 25°C. Keep batteries away from heat sources or main air ventilation area, etc.



WARNING!

Typical battery performance data are quoted for an operating temperature between 20°C and 25°C. Operating it above this range will reduce the battery life while operation below this range will reduce the battery capacity.

◆ Should the equipment not be installed immediately it must be stored in a room so as to protect it against excessive humidity and or heat sources.



CAUTION!

An unused battery must be recharged every 6months Temporarily connecting the UPS to a suitable AC supply mains and activating it for the time required for recharging the batteries.

◆ The highest altitude that UPS may work normally with full load is 1500 meters. The load capacity should be reduced when this UPS is installed in place whose altitude is higher than 1500 meters, shown as the following table:

(Load coefficient equals max load in high altitude place divided by nominal power of the UPS)

| | | | | | | | | |
|------------------|------|------|------|------|------|------|------|------|
| Altitude (m) | 1500 | 2000 | 2500 | 3000 | 3500 | 4000 | 4500 | 5000 |
| Load coefficient | 100% | 95% | 90% | 85% | 80% | 75% | 70% | 65% |

◆ The UPS cooling is depending on fan, so it should be kept in good air ventilation area. There are many ventilation holes on the front and rear, so they should not be blocked by any exotic obstacles.

3.5 External Protective Devices

For safety reasons, it is necessary to install, external circuit breaker at the input A.C. supply and the battery. This chapter provides guidelines for qualified installers that must have the knowledge of local wiring practices for the equipment to be installed.

◆ External Battery

The UPS and its associated batteries are protected against the effect of over-current through a DC compatible thermo-magnetic circuit-breaker (or a set of fuses) located close to the battery.

◆ UPS Output

Any external distribution board used for load distribution shall be fitted with protective devices that may avoid the risk of UPS overloaded.

◆ Over-current

Protection device shall be installed at the distribution panel of the incoming main supply. It may identify the power cables current capacity as well as the overload capacity of the system.



CAUTION!

Select a thermo magnetic circuit-breaker with an IEC 60947-2 trip curve C (normal) for 125% of the current as listed below.

3.6 Power Cables

◆ The cable design shall comply with the voltages and currents provided in this section, Kindly follow local wiring practices and take into consideration the environmental conditions (temperature and physical support media) .



WARNING!

Upon starting. Please ensure that you are aware of the location and operation of the external isolators which are connected to the UPS input/bypass supply of the mains distribution panel. Check to see if these supplies are electrically isolated. And post and necessary warning signs to prevent any inadvertent operation.

3.6.1 Recommended cross-sectional areas for power cables

| UPS cabinet | Cable Dimension | | | |
|-------------|-----------------------------|------------------------------|-----------------------------|------------------------------|
| | AC Input (mm ²) | AC Output (mm ²) | DC Input (mm ²) | Grounding (mm ²) |
| 50kVA | 25 | 16 | 50 | 16 |
| 60kVA | 35 | 35 | 50 | 25 |
| 80kVA | 50 | 50 | 70 | 35 |
| 100kVA | 70 | 50 | 120 | 35 |
| 120kVA | 95 | 70 | 150 | 50 |
| 150kVA | 120 | 95 | 185 | 70 |
| 160kVA | 120 | 95 | 185 | 70 |
| 180kVA | 150 | 100 | 120*2 | 95 |
| 200kVA | 150 | 100 | 120*2 | 95 |

- ◆ When selecting, connecting, and routing power cables, follow local safety regulations and rules.
- ◆ If external conditions such as cable layout or ambient temperatures change, perform verification in accordance with the IEC-60364-5-52 or local regulations.
- ◆ If the rated voltage is 400 V, multiply the currents by 0.95. If the rated voltage is 415 V, multiply the currents by 0.92.
- ◆ If primary loads are non-linear loads, increase the cross-sectional areas of neutral wires 1.5–1.7 times.
- ◆ The nominal battery discharge current refers to the current of forty 12 V batteries at 480V in standard configuration.
- ◆ The maximum battery discharge current refers to the current when forty 12 V batteries in standard configuration, that is, two hundred and forty 2 V battery cells (1.67 V/cell), stop discharging.
- ◆ The battery cable specifications are selected based on 40 batteries by default and compatible with application scenarios with 30–50 batteries.
- ◆ When the mains input and bypass input share a power source, configure both types of input power cables as mains input power cables. The cables listed in Table are used only when the following requirements are met:
 - Routing mode: Routing the cables over the cable ladder or bracket in a single layer (IEC60364-5-52 middle E).
 - The ambient temperature is 30°C.
 - The AC voltage loss is less than 3%, and the DC voltage loss is less than 1%.
 - 90°C copper flexible cable.
 - The length of the AC power cables of a UPS is no longer than 30 m and DC power cables no longer than 50 m.

3.6.2 Power cable connector requirements

| Model | Connector | Connection Mode | Bolt Type | Bolt Hole Diameter | Torque |
|-----------|-------------------------|----------------------|-----------|--------------------|--------|
| 50-60kVA | Mains input connector | Crimped OT terminals | M8 | 8.5mm | 26N•m |
| | Bypass input connector | Crimped OT terminals | M8 | 8.5mm | 26N•m |
| | Battery input connector | Crimped OT terminals | M10 | 10.5mm | 44N•m |
| | Output connector | Crimped OT terminals | M8 | 8.5mm | 26N•m |
| | Grounding connector | Crimped OT terminals | M8 | 8.5mm | 26N•m |
| 80-120kVA | Mains input connector | Crimped OT terminals | M10 | 10.5mm | 44N•m |
| | Bypass input connector | Crimped OT terminals | M10 | 10.5mm | 44N•m |
| | Battery input connector | Crimped OT terminals | M10 | 10.5mm | 44N•m |
| | Output connector | Crimped OT terminals | M10 | 10.5mm | 44N•m |
| | Grounding connector | Crimped OT terminals | M10 | 10.5mm | 44N•m |

| | | | | | |
|------------|-------------------------|----------------------|-----|--------|-------|
| 150-160kVA | Mains input connector | Crimped OT terminals | M10 | 10.5mm | 44N•m |
| | Bypass input connector | Crimped OT terminals | M10 | 10.5mm | 44N•m |
| | Battery input connector | Crimped OT terminals | M10 | 10.5mm | 44N•m |
| | Output connector | Crimped OT terminals | M10 | 10.5mm | 44N•m |
| | Grounding connector | Crimped OT terminals | M10 | 10.5mm | 44N•m |
| 180-200kVA | Mains input connector | Crimped OT terminals | M10 | 10.5mm | 44N•m |
| | Bypass input connector | Crimped OT terminals | M10 | 10.5mm | 44N•m |
| | Battery input connector | Crimped OT terminals | M10 | 10.5mm | 44N•m |
| | Output connector | Crimped OT terminals | M10 | 10.5mm | 44N•m |
| | Grounding connector | Crimped OT terminals | M10 | 10.5mm | 44N•m |

3.6.3 Recommended input front-end and output back-end circuit breakers

| UPS capacity | Component | Specifications |
|--------------|------------------------------|----------------|
| 50kVA | Mains input circuit breaker | 100A 3P |
| | Bypass input circuit breaker | 100A 3P |
| | Output circuit breaker | 100A 3P |
| | Battery circuit breaker | 160A 3P |
| 60kVA | Mains input circuit breaker | 125A 3P |
| | Bypass input circuit breaker | 125A 3P |
| | Output circuit breaker | 125A 3P |
| | Battery circuit breaker | 200A 3P |
| 80kVA | Mains input circuit breaker | 160A 3P |
| | Bypass input circuit breaker | 160A 3P |
| | Output circuit breaker | 160A 3P |
| | Battery circuit breaker | 250A 3P |
| 100kVA | Mains input circuit breaker | 200A 3P |
| | Bypass input circuit breaker | 200A 3P |
| | Output circuit breaker | 200A 3P |
| | Battery circuit breaker | 320A 3P |
| 120kVA | Mains input circuit breaker | 250A 3P |
| | Bypass input circuit breaker | 250A 3P |
| | Output circuit breaker | 250A 3P |
| | Battery circuit breaker | 400A 3P |

| | | |
|------------|------------------------------|---------|
| 150-160kVA | Mains input circuit breaker | 320A 3P |
| | Bypass input circuit breaker | 320A 3P |
| | Output circuit breaker | 320A 3P |
| | Battery circuit breaker | 500A 3P |
| 180-200kVA | Mains input circuit breaker | 400A 3P |
| | Bypass input circuit breaker | 400A 3P |
| | Output circuit breaker | 400A 3P |
| | Battery circuit breaker | 630A 3P |



CAUTION!

Protective earth cable: Connect each cabinet to the main ground system. For Grounding connection, follow the shortest route possible.



WARNING!

Failure to follow adequate earthing procedures may result in electromagnetic interference or in hazards involving electric shock and fire

3.7 Power cable connect

Once the equipment has been finally positioned and secured, connect the power cables as described in the following procedure.

Verify the UPS is totally isolated from its external power source and also all power isolators of the UPS are open. Check to see if they are electrically isolated, and post any necessary warning signs to prevent their inadvertent operation.

Open the UPS rear panel; Remove the cover of terminals for wiring easily.

3.7.1 Common input connection

50kVA&60kVA

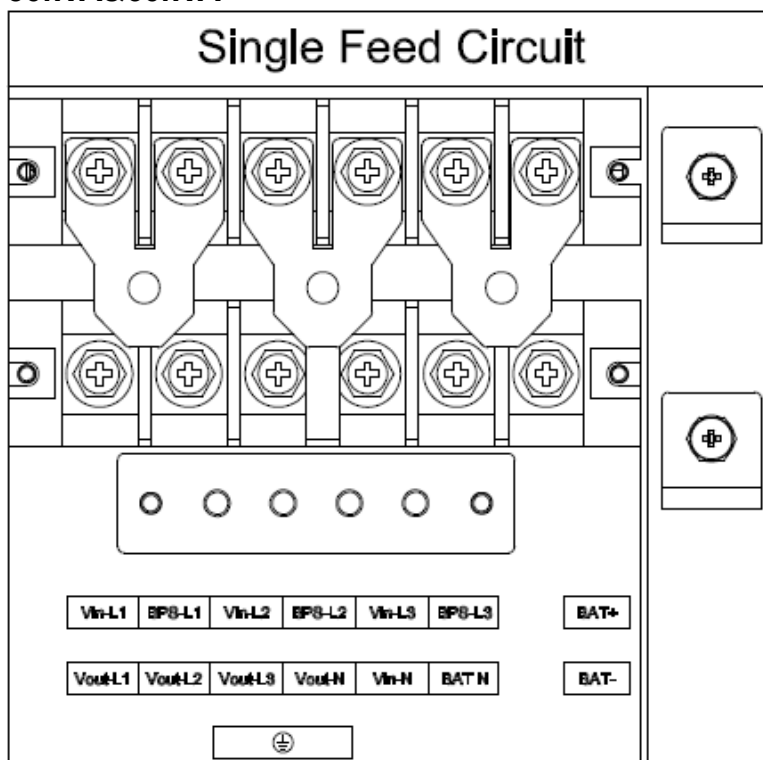

80kVA

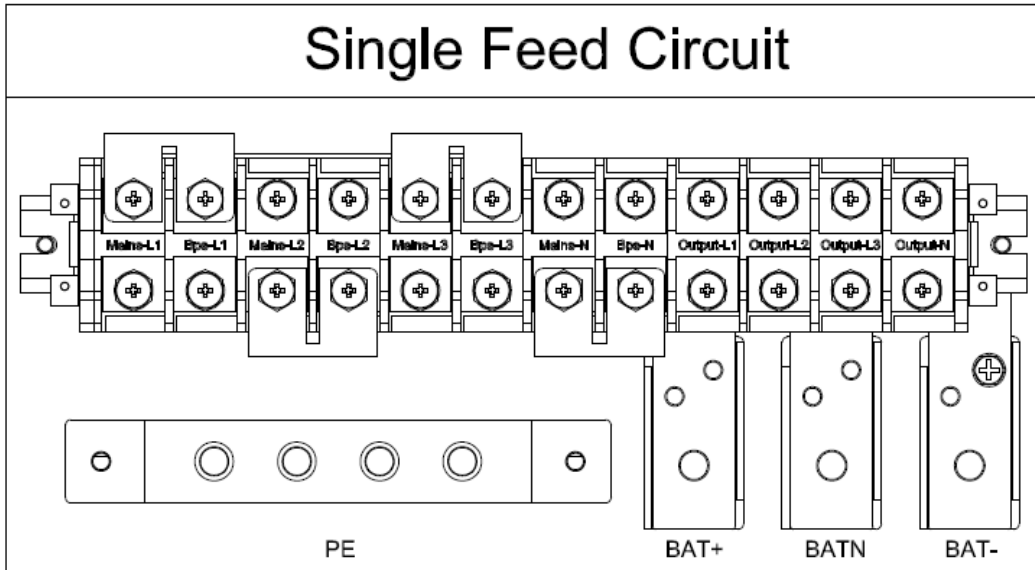

100kVA-160 kVA

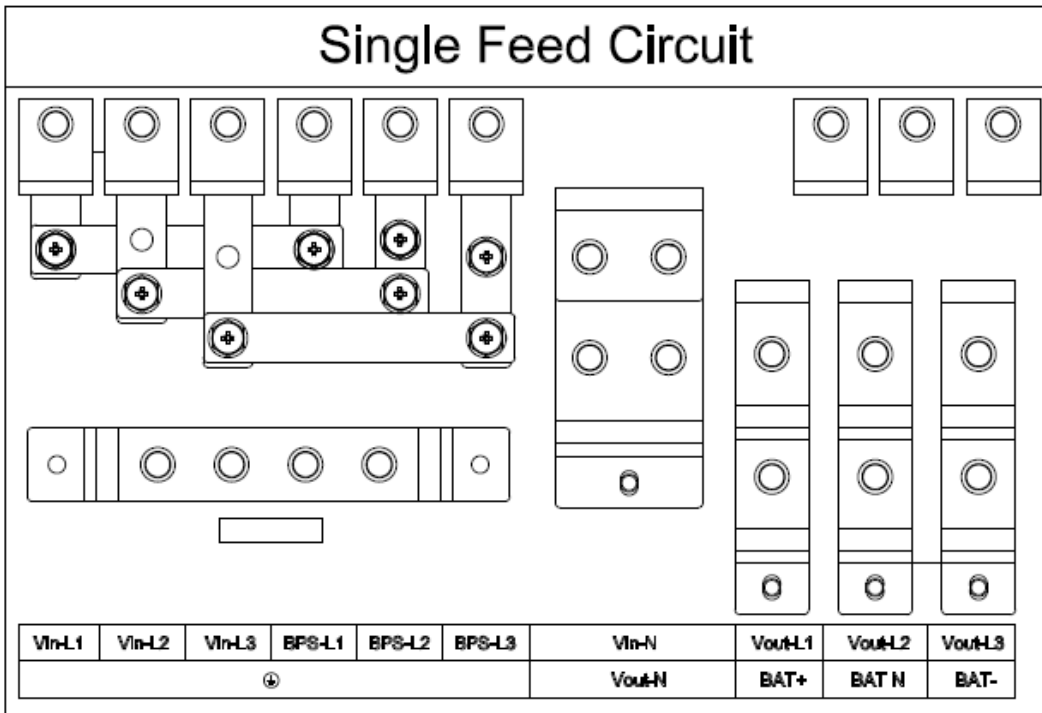

180-200 kVA

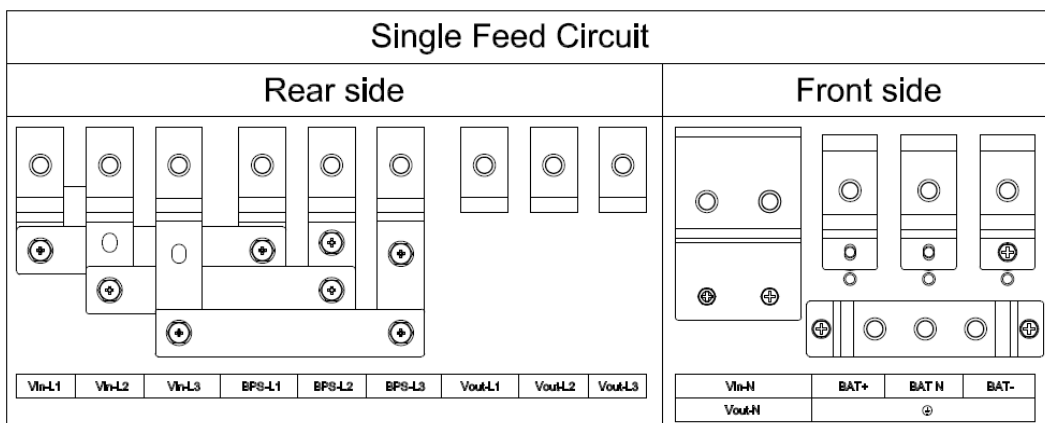

| INPUT Primary input Line | OUTPUT |
|---|--|
| | Vout-L1: Output Phase L1 |
| Vin-L1: Primary input Phase L1 | Vout -L2: Output Phase L2 |
| Vin-L2: Primary input Phase L2 | Vout -L3: Output Phase L3 |
| Vin-L3: Primary input Phase L3 | Vout -N: Output Neutral |
| Vin-N: Input Neutral for primary and secondary input | PE: Grounding |
| | BAT+: Positive terminal of the batteries string |
| | BATN: Neutral terminal of the batteries string |
| | BAT-: Negative terminal of the batteries string |

3.7.2 Dual input connection

50kVA & 60kVA

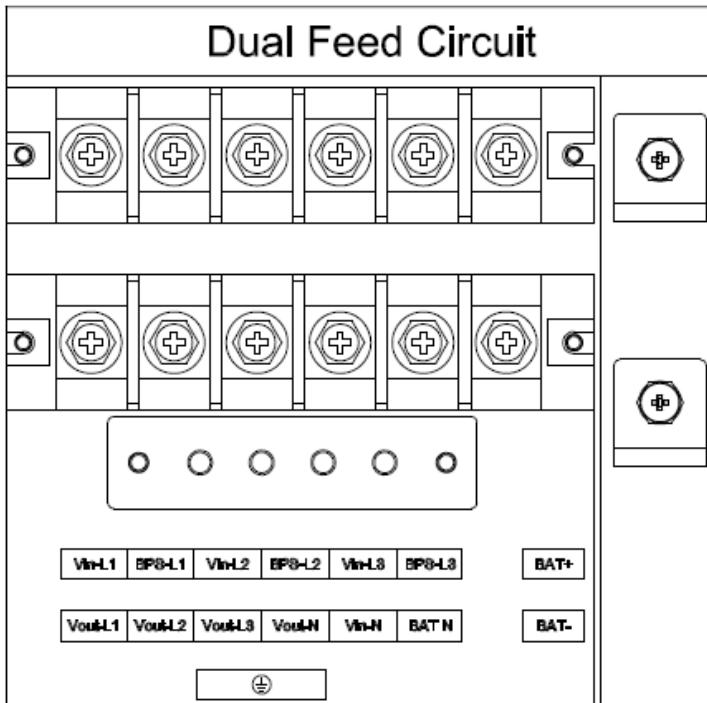

80kVA

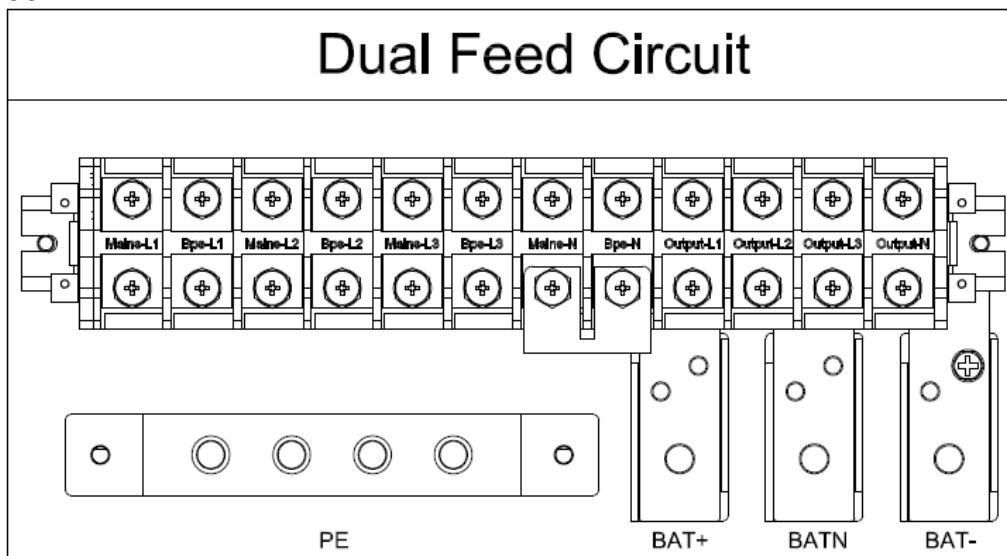

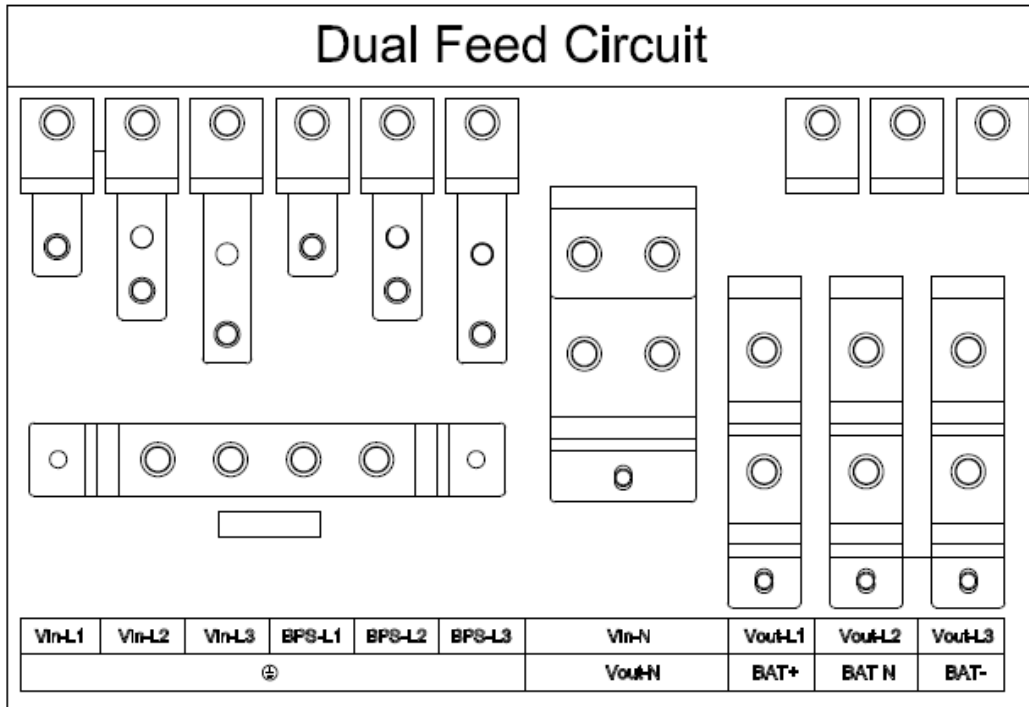
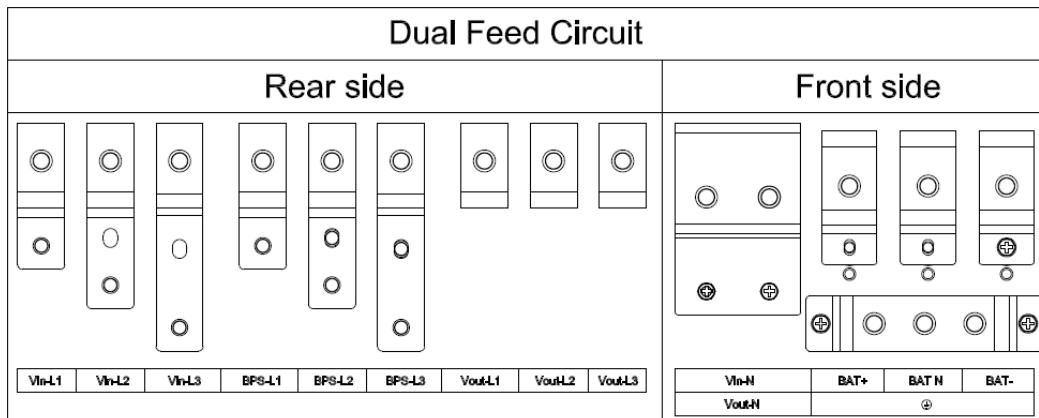
100kVA -160kVA

180-200kVA

| Mains Primary input Line | Output |
|---|--|
| Bypass Secondary/Bypass input line (optional) | Vout-L1: Output Phase L1 |
| Vin-L1: Primary input Phase L1 | Vout-L2: Output Phase L2 |
| Vin-L2: Primary input Phase L2 | Vout-L3: Output Phase L3 |
| Vin-L3: Primary input Phase L3 | Vout-N: Output Neutral |
| Vin-N: Input Neutral for primary and secondary input | PE: Grounding |
| BPS-L1: Secondary input Phase L1 | BAT+: Positive terminal of the batteries string |
| BPS-L2: Secondary input Phase L2 | BATN: Neutral terminal of the batteries string |
| BPS-L3: Secondary input Phase L3 | BAT-: Negative terminal of the batteries string |

Warning!

In the case of “Dual input” operation, make sure the copper wire between each input lines have been removed. The AC input and the AC bypass supplies must be referenced to the same neutral point.

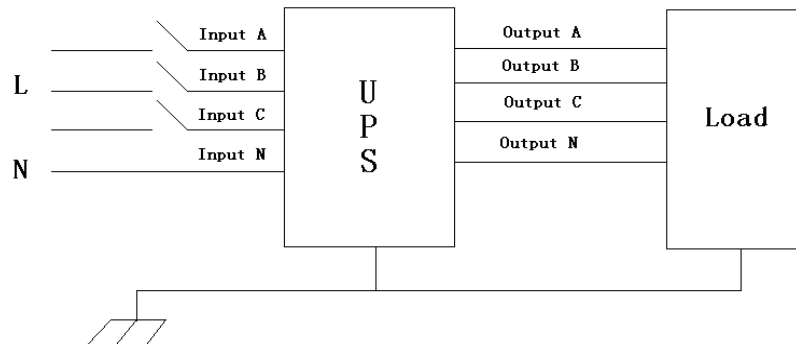
Choose appropriate power cable. (Refer to the table above) and pay attention to the diameter of the connection terminal of the cable that should be greater than or equal to that of the connection poles;



WARNING!



If the load equipment is not ready to accept power on the arrival of the commissioning engineer then ensure that the system output cables are safely isolated at their ends

Connect the safety earth and any necessary bonding earth cables to the copper earth screw located on the floor of the equipment below the power connections. All cabinets in the UPS must be grounded properly.



CAUTION!

The earthing and neutral bonding arrangement must be in accordance with local and national codes of practice.

3.8 Battery connection

The UPS adopts positive and negative double battery framework, total 30(optional 32/34/36/38/40/42/44/46/48/50) in series. A neutral cable is retrieved from the joint between the cathode of the 15th (16th/17th/18th/19th/20th/21th/22th/23th/24th/25th) and the anode of the 16th (17th/18th/19th/20th/21th/22th/23th/24th/25th/26th) of the batteries. Then the neutral cable, the battery Positive and the battery negative are connected with the UPS respectively. The battery sets between the Battery anode and the neutral are called positive batteries and that between neutral and cathode are called negative ones. The user can choose the capacity and the numbers of the batteries according to their desire.

External battery connections for long-run units.

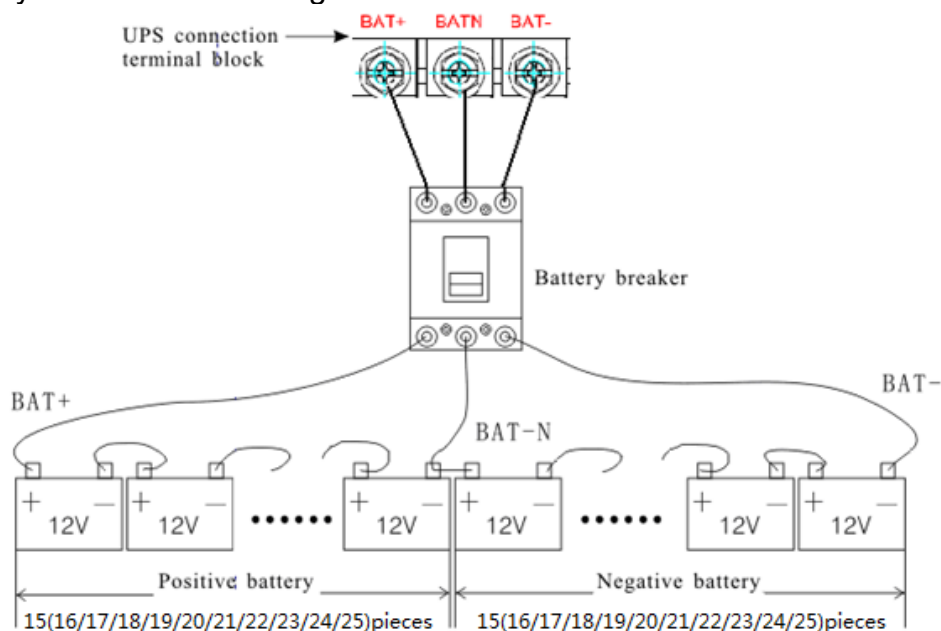

Note:

The BAT+ of the UPS connect poles is connected to the anode of the positive battery, the BAT-N is connected to the cathode of the positive battery and the anode of the negative battery, the BAT- is connected to the cathode of the negative battery.

factory setting of the long-run unit is battery quantity---30pcs, battery capacity---12V100AH (charger current 15A). When connecting 32/34/36/38/40/42/44/46/48/50 batteries, please re-set desired battery quantity and its capacity after UPS starts at AC mode. Charger current could be adjusted automatically according to battery capacity selected. All related settings can be done through LCD panel or monitoring software



CAUTION!

Ensure correct polarity battery string series connection. I.e. inter-tier and inter block connections are from (+) to (-) terminals. Don't mix batteries with different capacity or different brands, or even mix up new and old batteries, either.



WARNING!

Ensure correct polarity of string end connections to the Battery Circuit Breaker and from the Battery Circuit Breaker to the UPS terminals i.e. (+) to (+) / (-) to (-) but disconnect one or more battery cell links in each tier. Do not reconnect these links and do not close the battery circuit breaker unless authorized by the commissioning engineer.

3.9 UPS parallel Installation

The following sections introduce the installation procedures specified to the parallel system.

3.9.1 Cabinet installation

Connect all the UPS needed to be put into parallel system as below picture.

Common input:

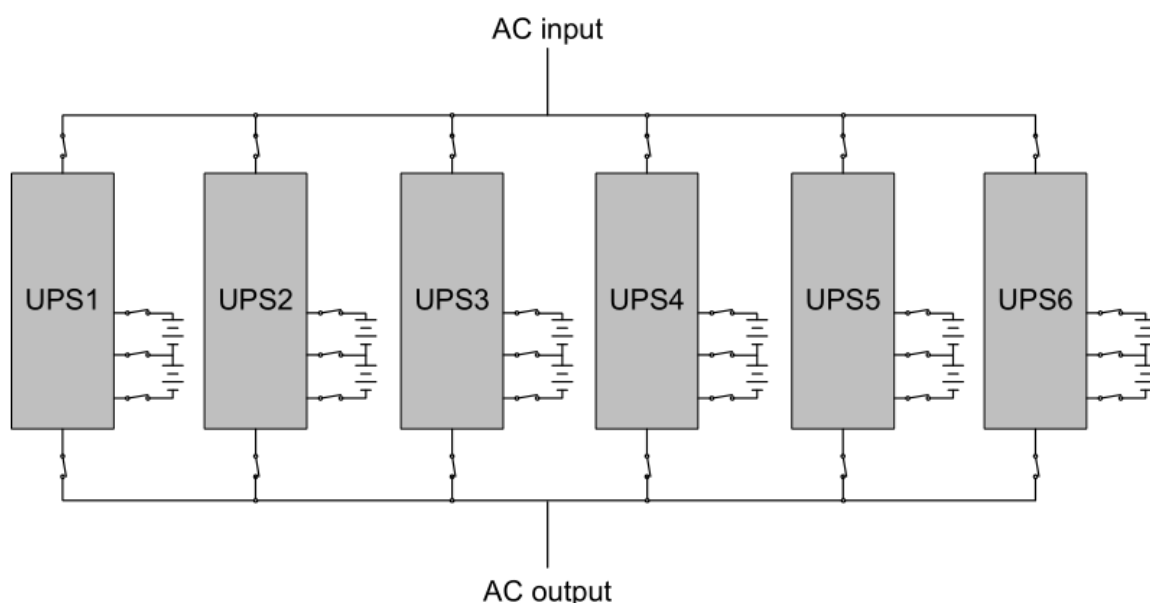

Dual input:

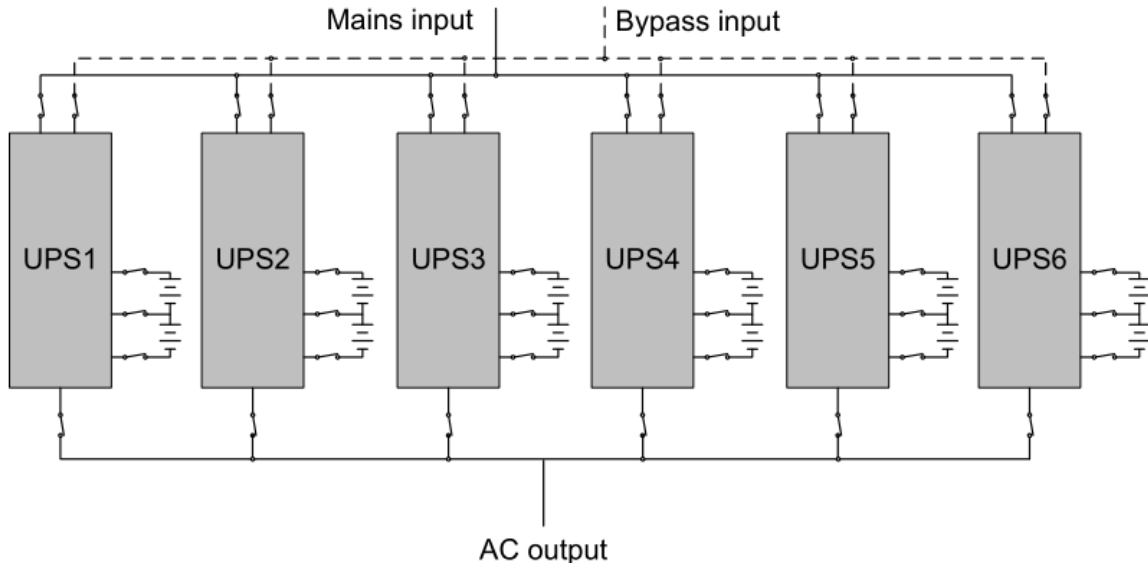

Make sure each UPS input breaker is in “off” position and there is no any output from each UPS connected. Battery groups can be connected separately or in parallel, which means the system itself provides both separate battery and common battery.



WARNING!

Make sure the N, A (L1), B (L2), C (L3) lines are correct, and grounding is well connected.

3.9.2 Parallel cable installation

Shielded and double insulated control cables available must be interconnected in a ring configuration between UPS units as shown below. The ring configuration ensures high reliability of the control.

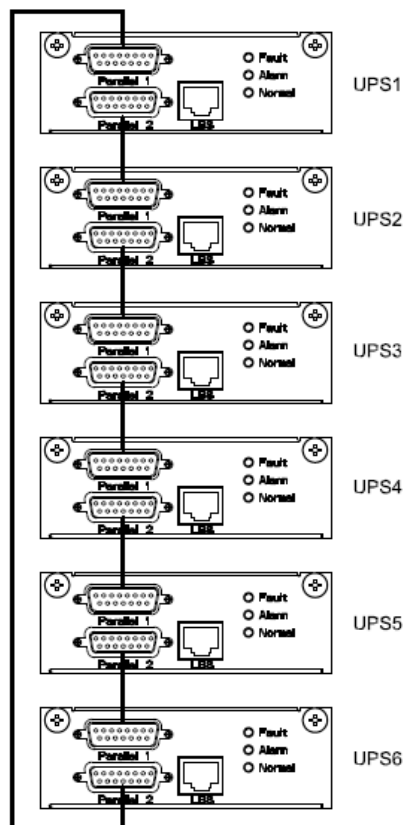

3.9.3 Requirement for the parallel system

A group of paralleled UPS behaves as one large UPS system but with the advantage of presenting higher reliability. In order to assure that all UPS are equally utilized and comply with relevant wiring rules, please follow the requirements below:

- 1) All UPS must be of the same rating and be connected to the same bypass source.
- 2) The outputs of all the UPS must be connected to a common output bus.
- 3) The length and specification of power cables including the bypass input cables and the UPS output cables should be the same. This facilitates load sharing when operating in bypass mode.

3.10 LBS installation

LBS system contains LCD set, communication cable and STS device.

3.10.1 LCD setting

Set every UPS of the systems to be LBS Master or LBS Slave. For instance if the UPS belongs to LBS master system, its LBS setting must be set to Master.

3.10.2 LBS cable installation

The two ports of one mesh wire should be plug into RJ45 interface of any one UPS of both master and slave system.

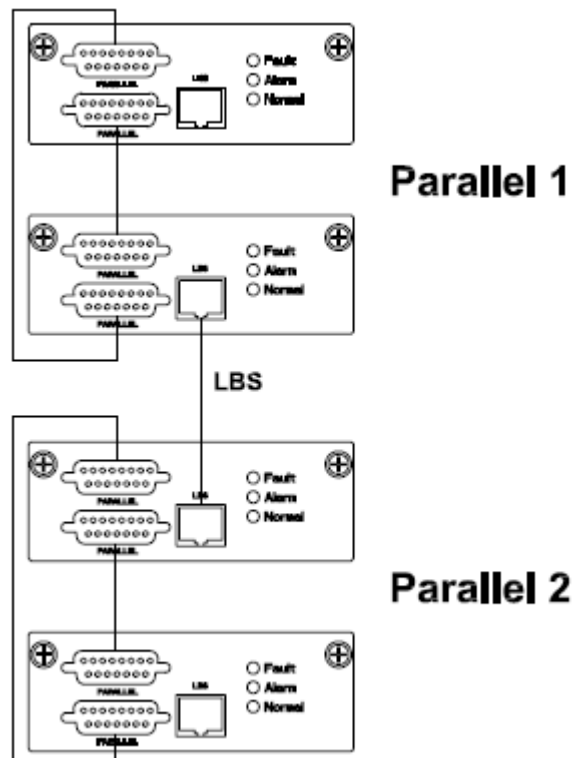

3.10.3 UPS installation

The whole systems is showed below.

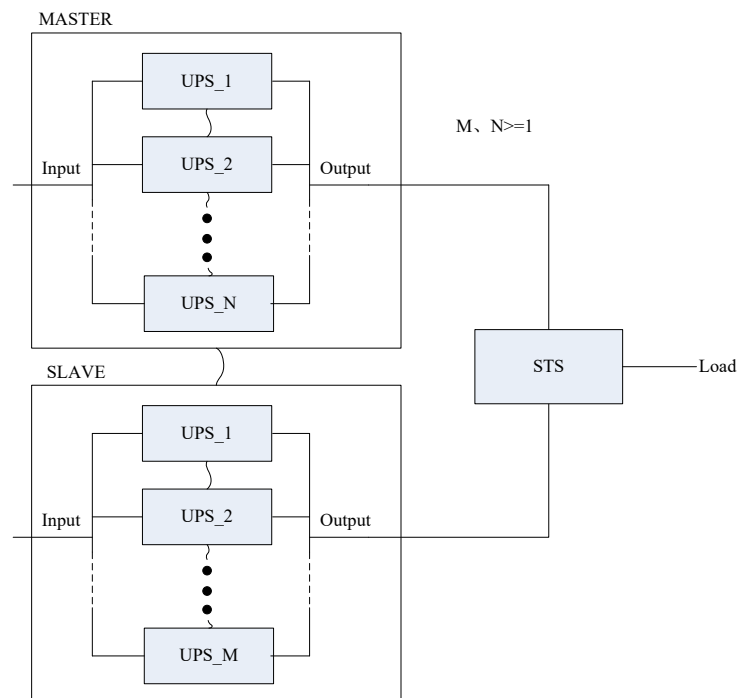

3.11 Computer access

- ◆ One end of a USB cable connect to the computer, the other end connect to the USB port on the UPS.
- ◆ Open the software Muser5000, click “system” button.

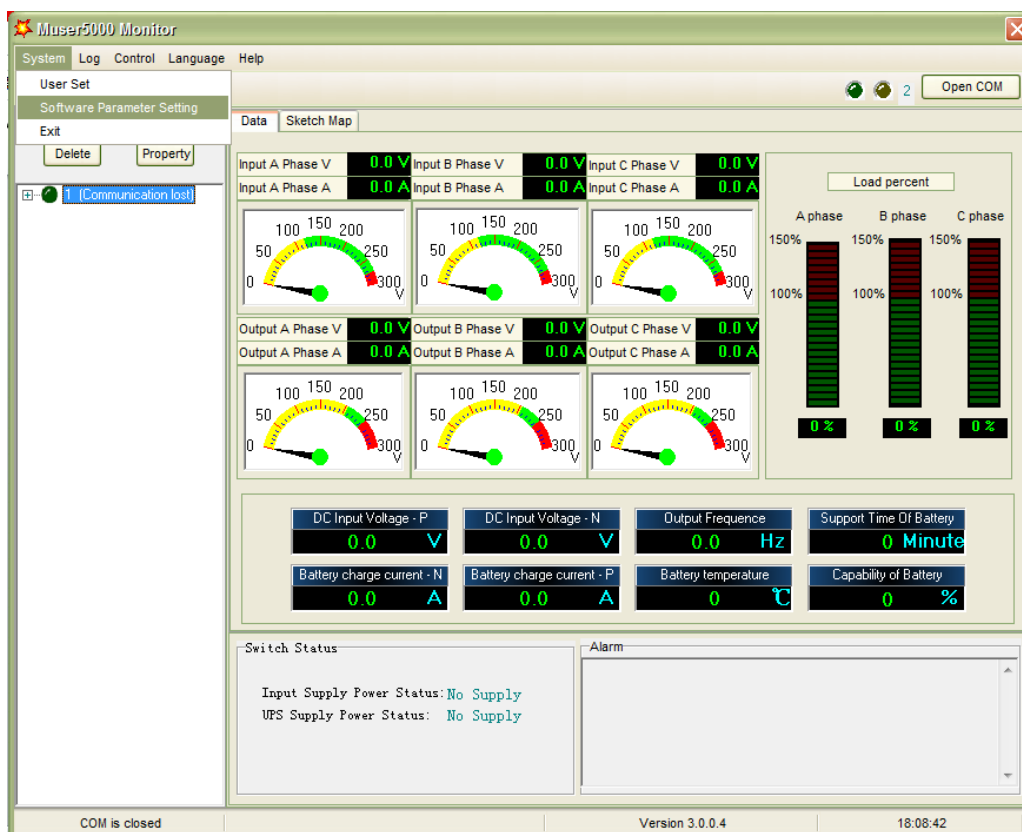

◆A window of “Software Parameter Setting” comes out as below, COM choose according to the UPS , baud rate choose 9600, protocol choose “modbus”, then save this setting.

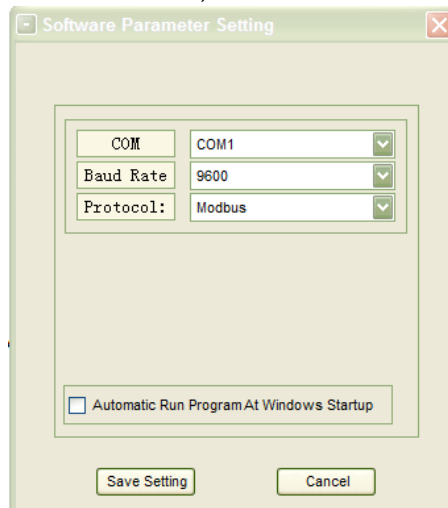

◆On the main page of Muser5000, click the button of “Append”, then goes to a window of “Append equipment”.

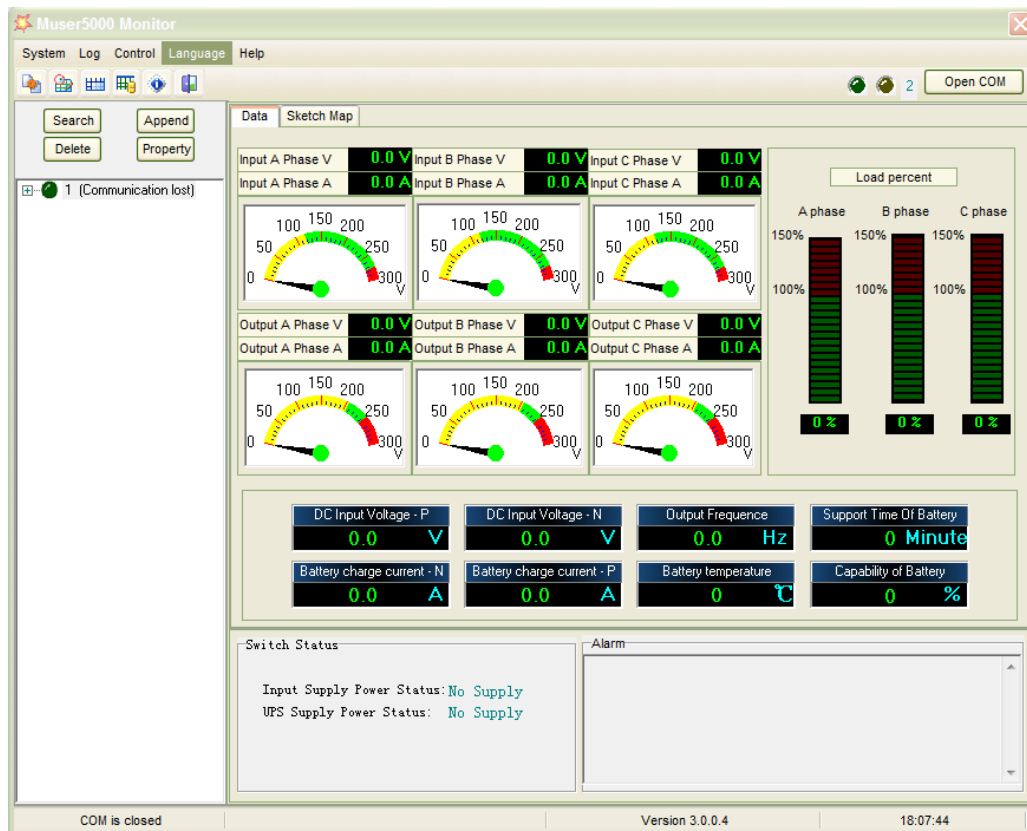

◆Put the UPS name into “Equipment Name”, and UPS’ ID address into “Equipment address”.

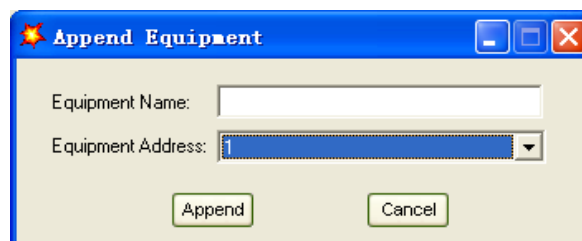

◆ Click the button “Append”, then the connection between UPS & computer is accomplished.



CAUTION!

When the UPS worked on inverter. If you want to use PC to set the output voltage and frequency. Must shut down the inverter first

4. Operation

4.1 Operation Modes

The UPS is a double-conversion on-line UPS that may operate in the following alternative modes :

◆ **Normal mode**

The rectifier/charger derives power from the AC Mains and supplies DC power to the inverter while floating and boosting charge the battery simultaneously. Then, the inverter converts the DC power to AC and supplies to the load.

SINGLE INPUT: Mains Input

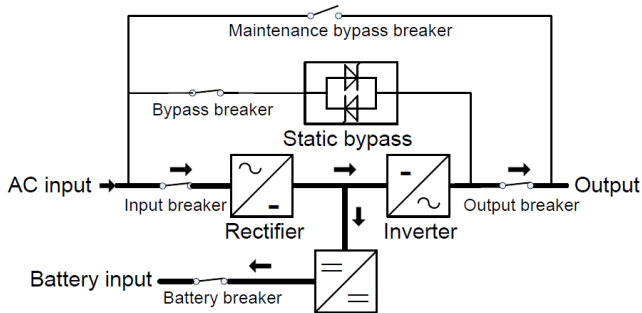

DUAL INPUT: Mains Input and Bypass Input

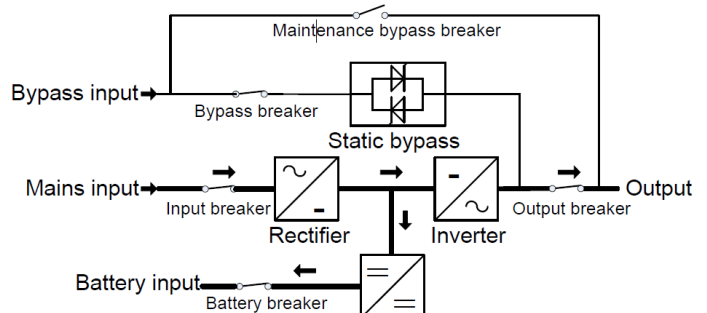

◆ **Battery mode (Stored Energy Mode)**

If the AC mains input power fails, the inverter, which obtains power from the battery, supplies the critical AC load. There is no power interruption to the critical load. The UPS will automatically return to Normal Mode when AC recovers.

SINGLE INPUT: Mains Input

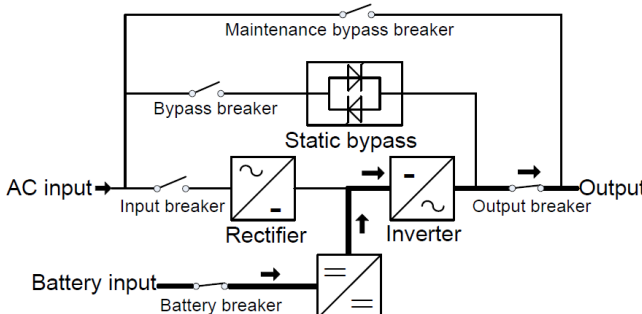

DUAL INPUT: Mains Input and Bypass Input

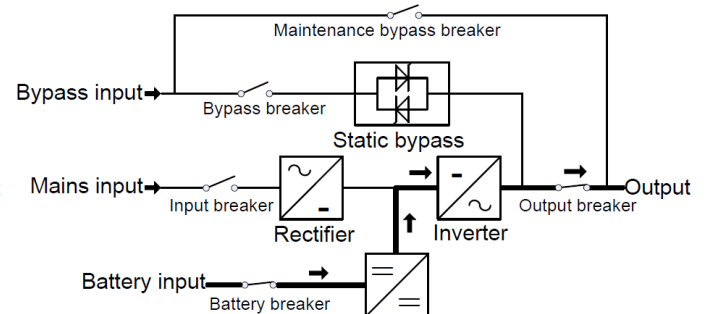

◆ Bypass mode

If the inverter is out of order, or if overload occurs, the static transfer switch will be activated to transfer the load from the inverter supply to bypass supply without interruption to the critical load. In the event that the inverter output is not synchronized with the bypass AC source, the static switch will perform a transfer of the load from the inverter to the bypass with power interruption to the critical AC load. This is to avoid paralleling of unsynchronized AC sources. This interruption is programmable but typically set to be less than an electrical cycle e.g. less than 15ms (50Hz) or less than 13.33ms (60Hz).

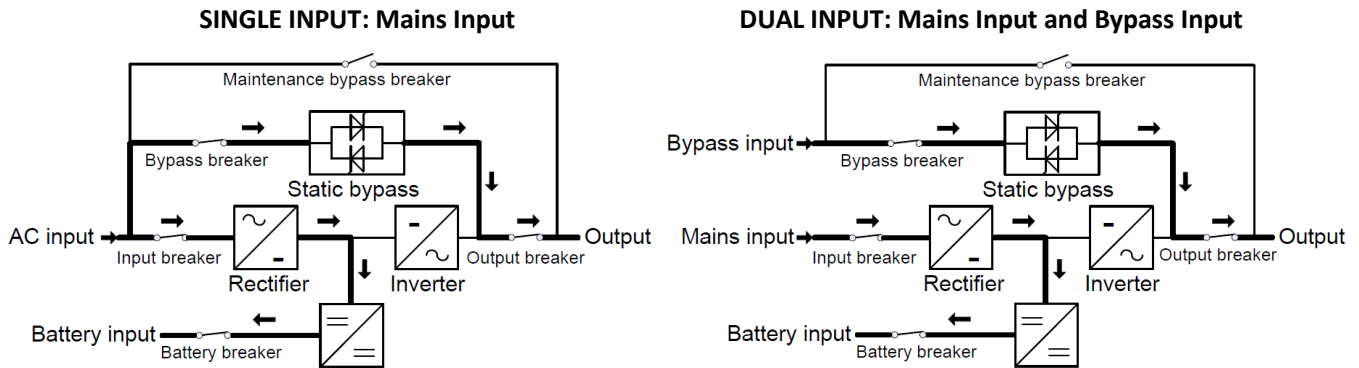

◆ ECO Mode

When the UPS is at AC Mode and the requirement to the load is not critical, the UPS can be set at ECO mode in order to increase the efficiency of the power supplied. At ECO mode, the UPS works at Line-interactive mode, so the UPS will transfer to bypass supply. When the AC is out of set window, the UPS will transfer from bypass to Inverter and supplies power from the battery, and then the LCD shows all related information on the screen.

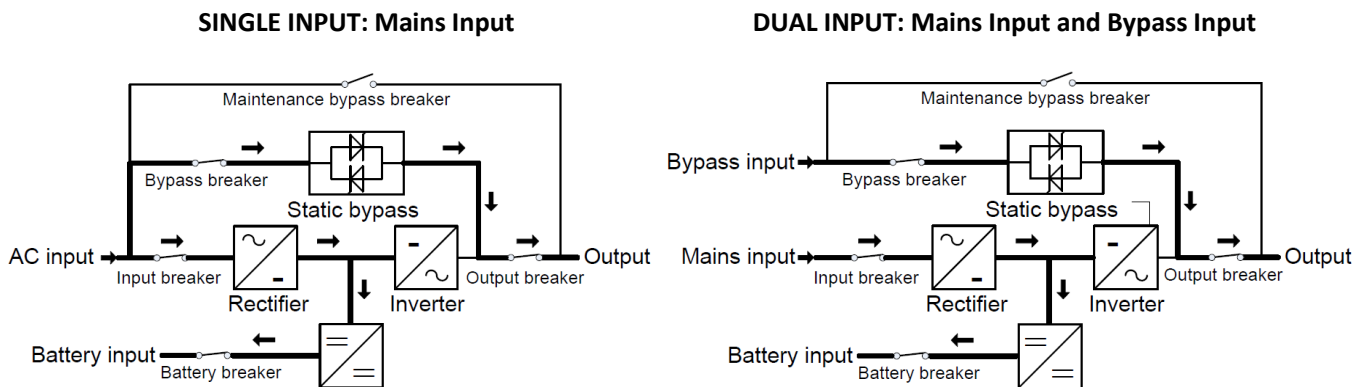

◆ Maintenance mode (Manual Bypass)

A manual bypass switch is available to ensure continuity of supply to the critical load when the UPS is out of order or in repair and this manual bypass switch bears for equivalent rated load.

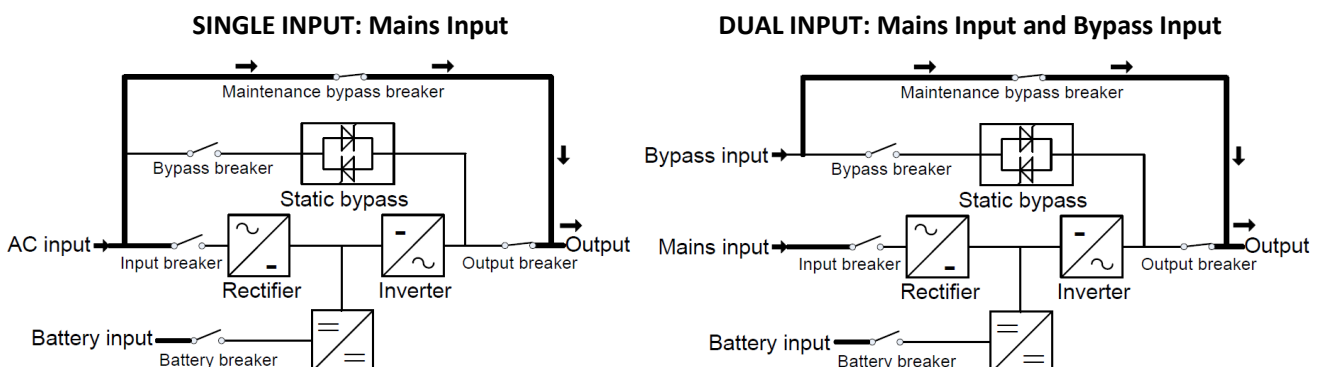

4.2 Turn on/off UPS

4.2.1 Restart procedure



CAUTION!

MAKE SURE GROUNDING IS PROPERLY DONE!

- ◆ Set the Battery Breaker to the “ON” position according to the user’s manual.



CAUTION!

Check to see if the load is safely connected with the output of the UPS. If the load is not ready to receive power from the UPS, make sure that it is safely isolated from the UPS output terminals

- ◆ Turn ON OUTPUT breaker. (Below the UPS power units at the front door)
- ◆ Turn ON BYPASS breaker and MAINS breaker. (Below the UPS power units at the front door)

If the Rectifier input is within voltage range, the rectifier will start up in 30 seconds then the inverter will start up after then.

If the rectifier fails at startup, the bypass LED will light up. When the inverter starts up, the UPS will transfer from bypass mode to inverter mode, then the bypass LED extinguishes and the inverter LED lights up.

No matter whether the UPS can work normally or not, all the status will be shown on the LCD display.

4.2.2 Test procedure



CAUTION!

The UPS is operating normally. It may take 60 seconds to boost up the system and perform self-test completely.

- ◆ Switch off the MAINS to simulate utility failure, the rectifier will turn off and the battery should feed the inverter without interruption. At this time, the LEDs of battery should be turned on.
- ◆ Switch on the MAINS to simulate utility recovery, the rectifier will restart automatically after 20 seconds and the inverter will supply to the load. It is suggested to use Dummy loads for testing. The UPS can be loaded up to its maximum capacity during load test ◦

4.2.3 MAINTENANCE BYPASS

To supply the load via Mains, you may simply active the internal mechanical bypass switch.



CAUTION!

The load is not protected by the UPS when the internal mechanical bypass system is active and the power is not conditioned.

Switch to mechanical bypass



CAUTION!

If the UPS is running normally and can be controlled through the display, carry out steps 1 to 6; otherwise, jump to Step 5.

- ◆ Open the cover of maintenance switch, the UPS turns to bypass mode automatically.
- ◆ Turn on MAINTANCE breaker;
- ◆ Switch OFF BATTERY breaker;
- ◆ Switch OFF MAINS breaker;
- ◆ Switch OFF BYPASS breaker;
- ◆ Switch OFF OUTPUT breaker;

At this time the bypass source will supply to the load through the MAINTENANCE breaker.

Switch to normal operation (from mechanical bypass)



CAUTION!

Never attempt to switch the UPS back to normal operation until you have verified that there are no internal UPS faults.

- ◆ Turn ON OUTPUT breaker.
- ◆ Turn ON BYPASS breaker.
- ◆ Turn ON MAINS breaker.

The UPS powers from the static bypass instead of the maintenance bypass, then the bypass LED will light up.

- ◆ Switch OFF the maintenance bypass breaker, then the output is supplied by the static bypass of the UPS.
- ◆ Put on the maintenance switch cover.

The rectifier will operate normally after 30 seconds. If the inverter works normally, the system will be transferred from bypass mode to normal mode.

4.2.4 Cold start procedure



CAUTION!

Follow these procedures when the input AC Utility Failure, but battery is normal

- ◆ Turn on the BATTERY breaker. The battery will feed the Auxiliary power board.
- ◆ Turn on the OUTPUT breaker.
- ◆ Trigger the cold start(Cold start) button as the position 11 of the below drawing.

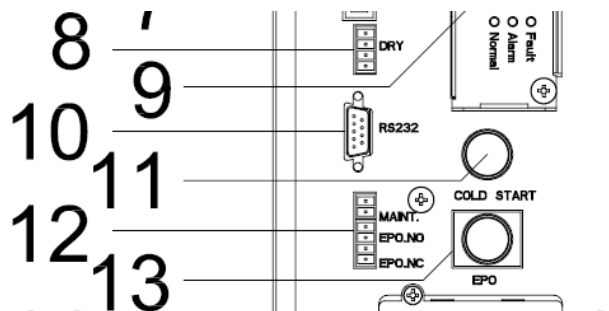

When battery normal, rectifier starts operation, 30s later, inverter starts and operates and battery LED on.

CAUTION!



Please press the close start button after 30 seconds until closing the battery switch.

4.2.5 Shut down procedure



CAUTION!

This procedure should be followed to completely shut down the UPS and the LOAD. After all power switches, isolators and circuit breakers are opened, there will be no output.

- ◆ Switch OFF the BATTERY breaker;
- ◆ Open the UPS door to easily access to the main power switch;
- ◆ Switch OFF the MAINS breaker.
- ◆ Switch OFF the BYPASS breaker.
- ◆ Open the OUTPUT breaker. The UPS shuts down;
- ◆ To completely isolate the UPS from AC Mains, all input switches of Utility shall be completely off, which includes the ones for rectifier and bypass.
- ◆ The primary input distribution panel, which is often located far away from the UPS area, so a label should be posted to advise service personnel that the UPS circuit is under maintenance.



WARNING!

Wait for about 5 minutes for the internal D.C. bus bar capacitors to be completely discharged.

4.2.6 Parallel setting

- ◆ Connect the UPS with computer. Power on the UPS.
- ◆ Open Muser5000 software, after connecting with the UPS successfully, click “System”->“User Set”

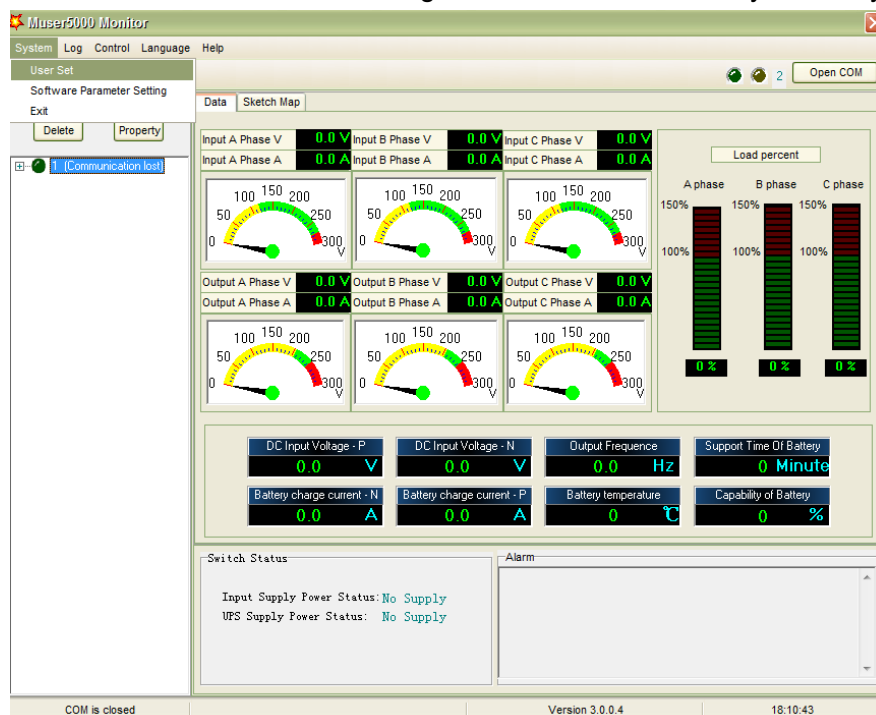

◆Click “Set” at “User Set” window;

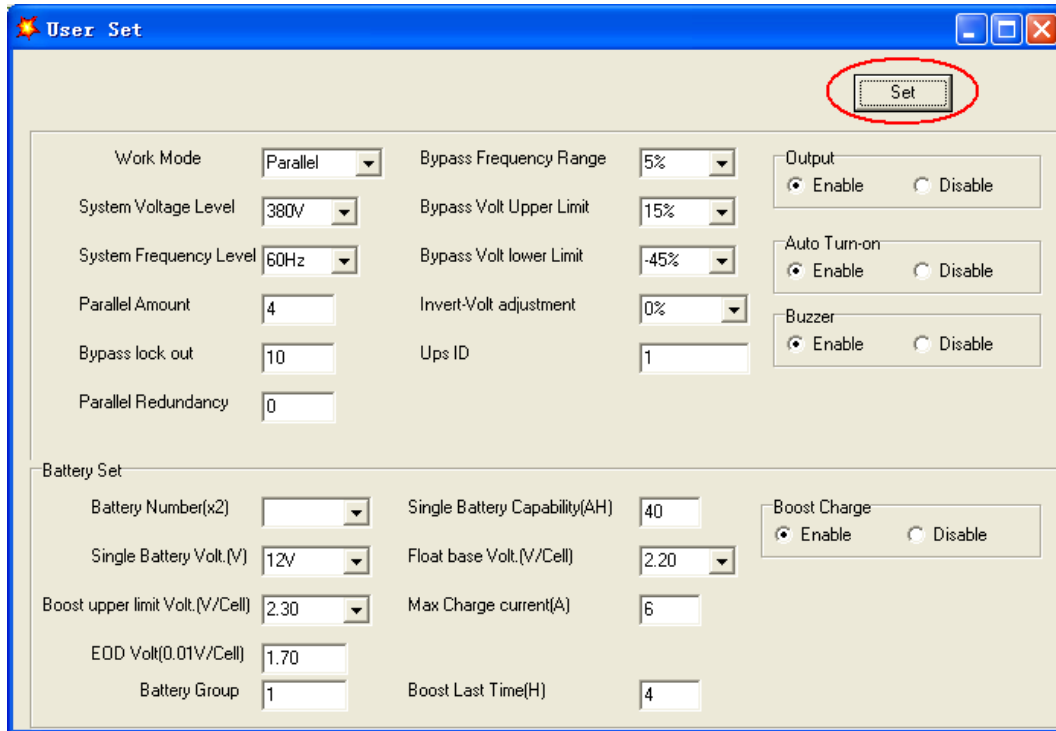

◆At the window of “Data Set”, click “Work Mode”,, choose “Parallel” for the value, then click “Set” as shown in below picture. If the UPS sounds a “beep”, that means the setting is correct.

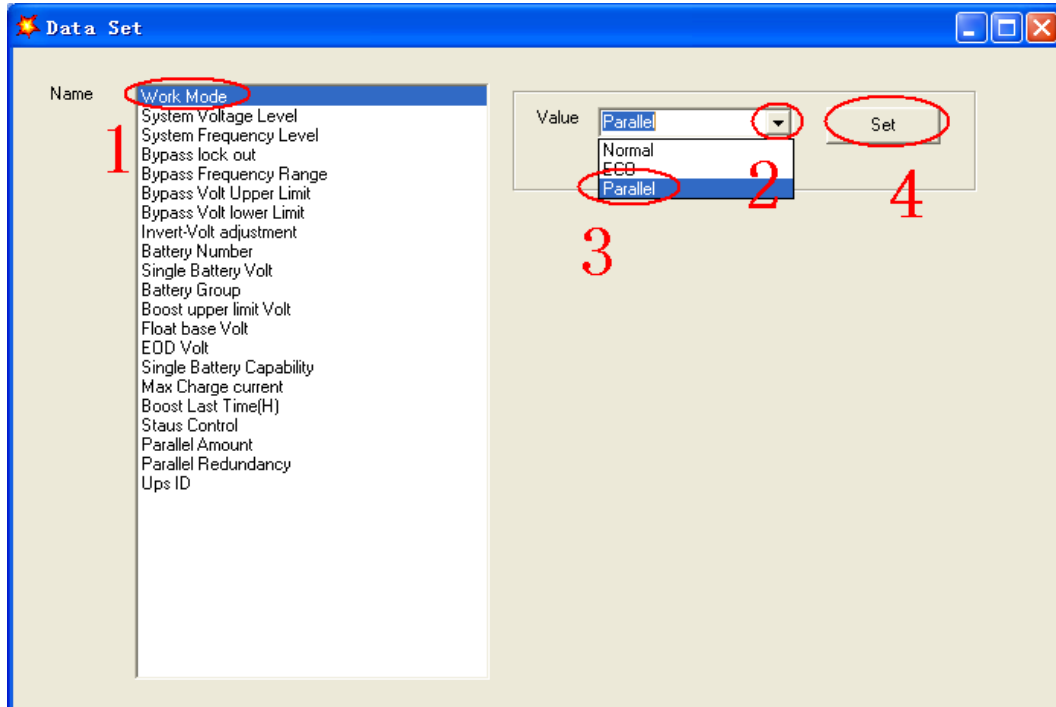

◆At the window of “Data Set”, click “Ups ID”, write a value for the parallel UPS ID at the right side, such as “1”, then click “Set” as shown in below picture. If the UPS sounds a “beep”, that means the setting is correct.

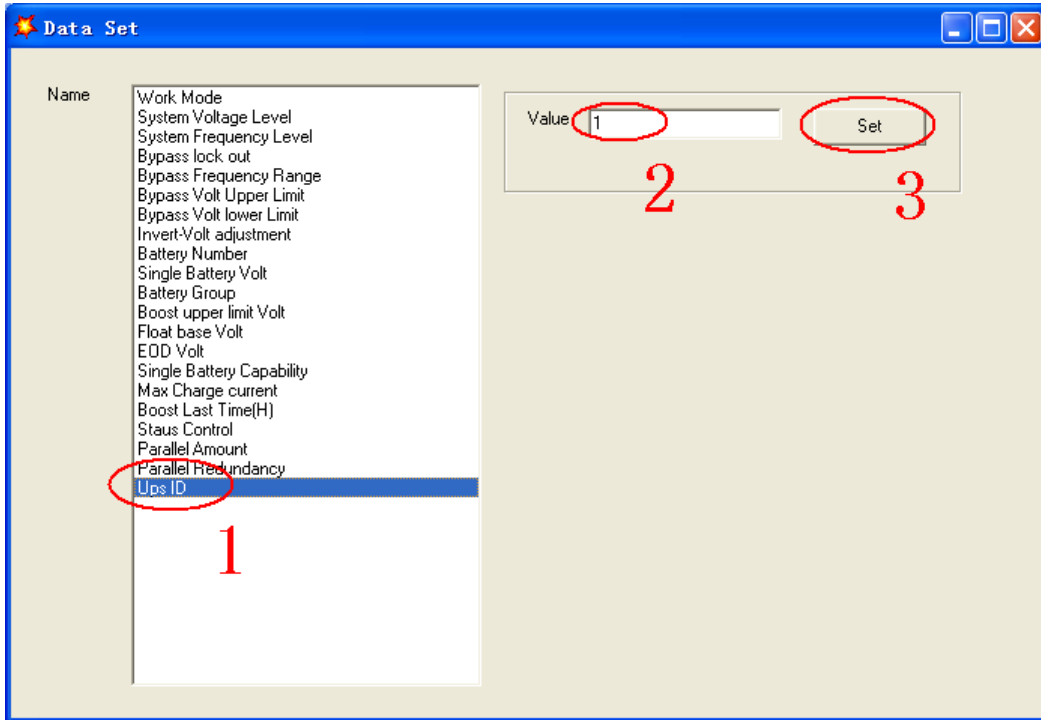

CAUTION!

After changing the parallel system ID, the connection between Muser4000 and equipment might be interrupted. If it occurs, please re-connect in accordance with the instruction described before.



CAUTION!

Parallel cable cannot be connected when setting the parallel parameters.

◆After setting the UPS needed to be paralleled, power off all the UPS. Connect all the UPS according to “parallel cable installation”, and then power on the UPS.

4.3 The LCD Display

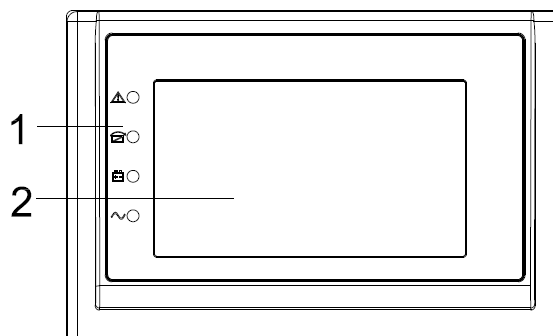

LCD control panel introduction

(1) LED (from top to bottom: “Fault”, “bypass”, “battery”, “inverter”)

(2) LCD display

Introduction



CAUTION!
 The display provides more functions than those described in this manual.

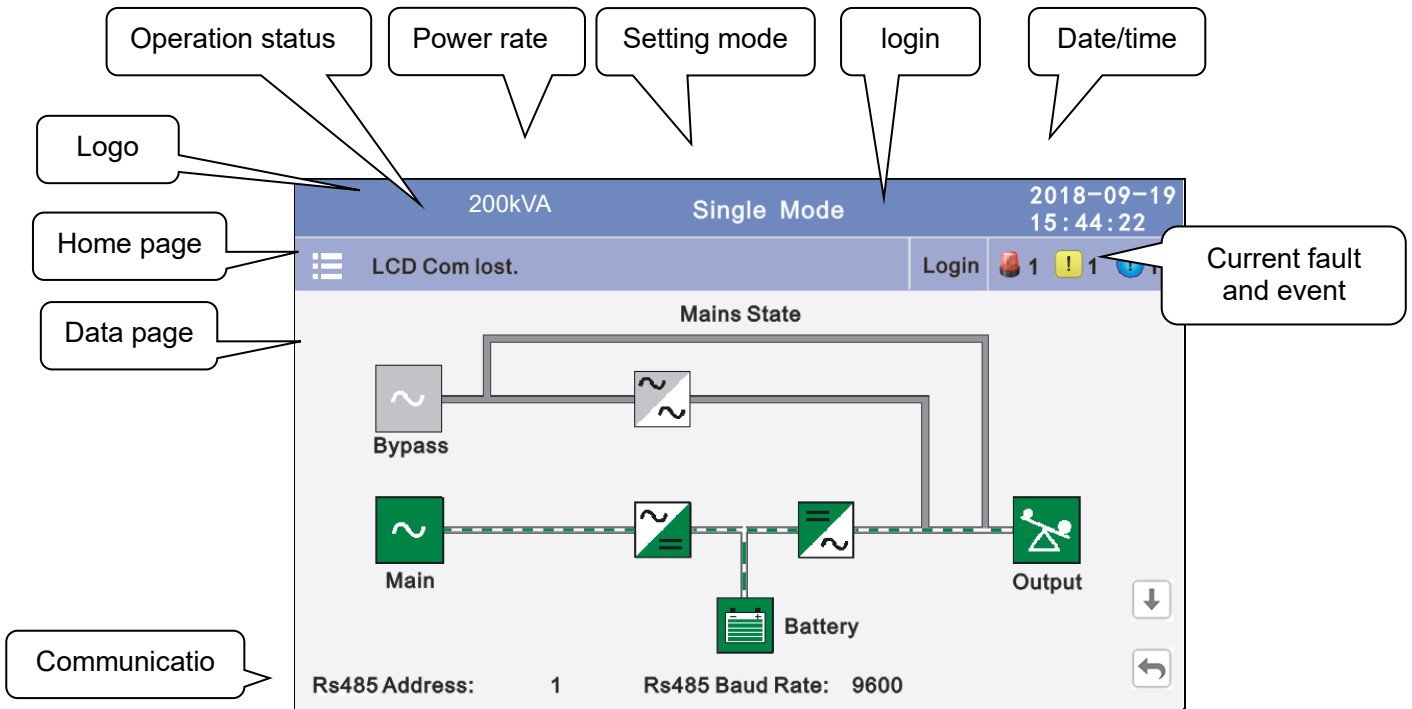

4.3.1 Datas: Displays the flow state of UPS work, and quickly enters real-time data by clicking on the block.

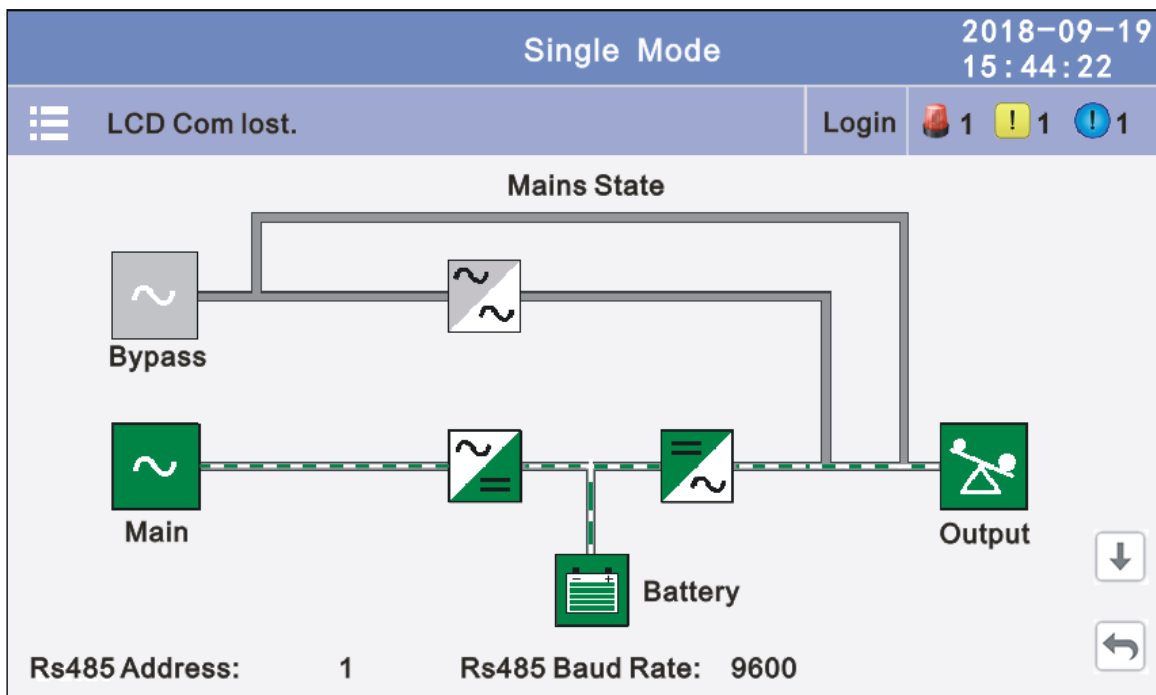

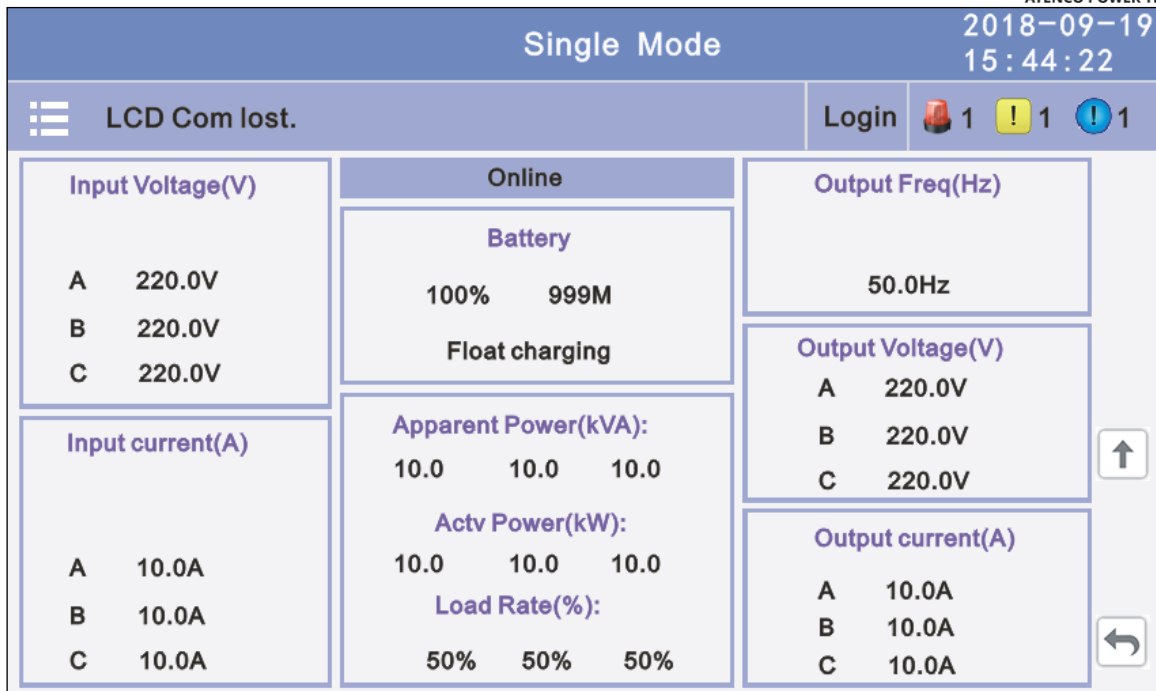

4.3.2 Status: View the voltage and current of the main, bypass, output, battery (can also be entered through by real-time data block), view the status of the switches, dry contacts, through clicking on the block, enter the corresponding data window.

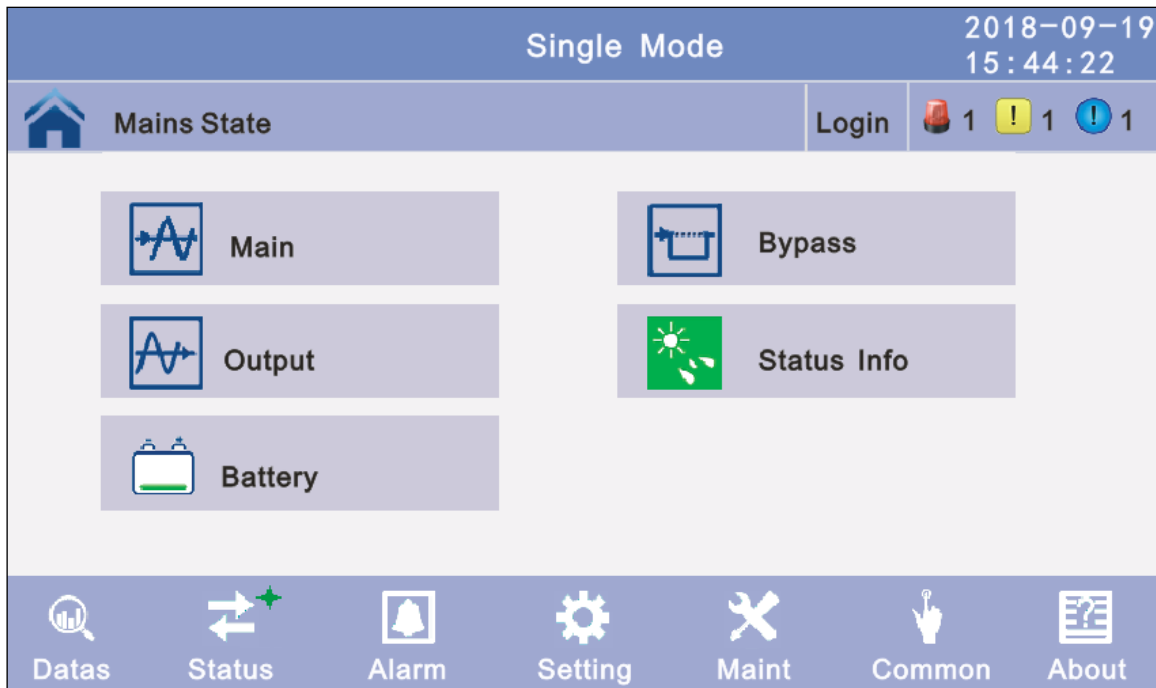

4.3.2.1 Main: Click the main block to enter the main data display window, click return to return to the previous window, click home page to return to the main page.

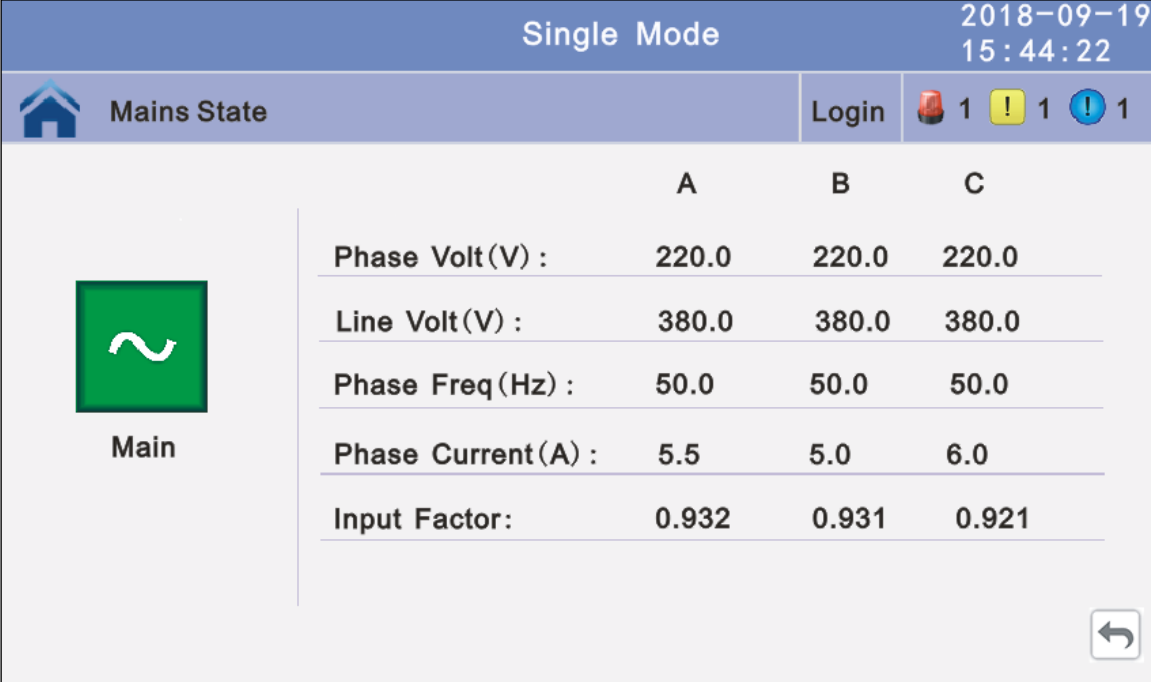

| | A | B | C |
|---------------------|-------|-------|-------|
| Phase Volt (V) : | 220.0 | 220.0 | 220.0 |
| Line Volt (V) : | 380.0 | 380.0 | 380.0 |
| Phase Freq (Hz) : | 50.0 | 50.0 | 50.0 |
| Phase Current (A) : | 5.5 | 5.0 | 6.0 |
| Input Factor: | 0.932 | 0.931 | 0.921 |



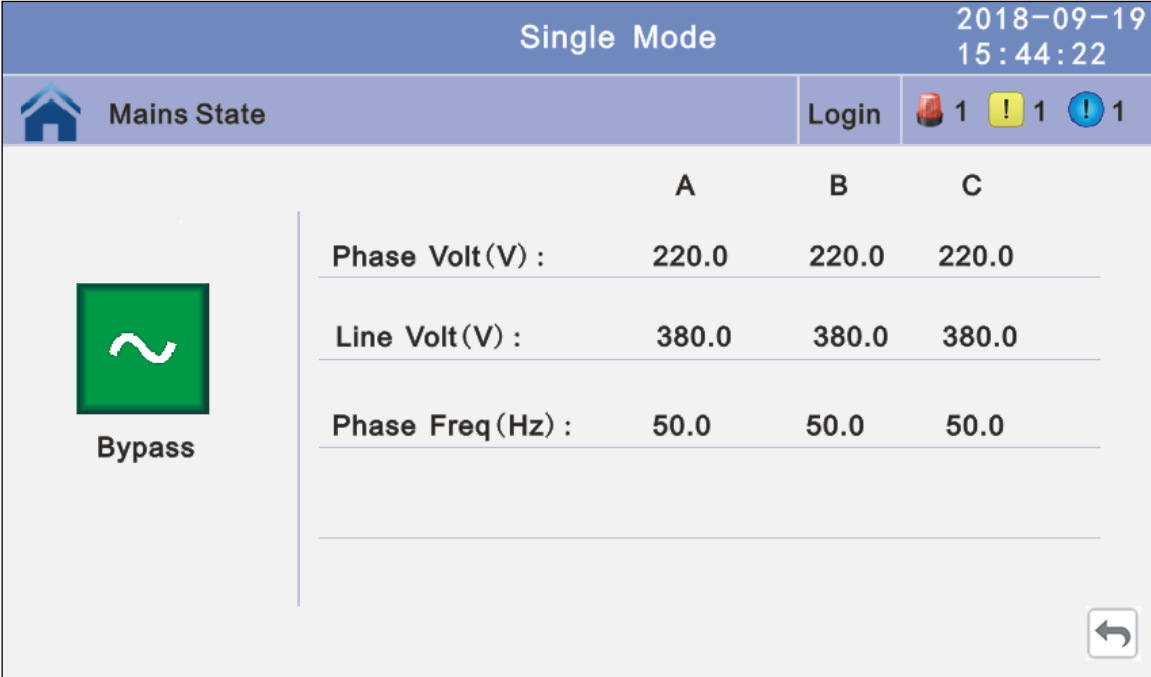

4.3.2.2 Bypass: Click the bypass block to enter the bypass data display window, click return to return to the previous window, click home page to return to the main page.





| | A | B | C |
|-------------------|-------|-------|-------|
| Phase Volt (V) : | 220.0 | 220.0 | 220.0 |
| Line Volt (V) : | 380.0 | 380.0 | 380.0 |
| Phase Freq (Hz) : | 50.0 | 50.0 | 50.0 |

4.3.2.3 Output: Click the output block to enter the output data display window, click return to return to the previous window, click home page to return to the main page.





Single Mode 2018-09-19
15:44:22

 Mains State Login  1  1  1



| | A | B | C |
|---------------------|-------|-------|-------|
| Phase Volt (V) : | 220.0 | 220.0 | 220.0 |
| Line Volt (V) : | 380.0 | 380.0 | 380.0 |
| Phase Freq (Hz) : | 50.0 | 50.0 | 50.0 |
| Phase Current (A) : | 5.5 | 5.0 | 6.0 |

Single Mode 2018-09-19
15:44:22

 Mains State Login  1  1  1

| | A | B | C |
|------------------------|------|------|------|
| Apparent Power (kVA) : | 1.0 | 1.0 | 1.0 |
| Actv Power (kW) : | 1.0 | 1.0 | 1.0 |
| Load Rate (%) : | 1.0% | 1.0% | 1.0% |
| Load Peak Ratio : | 1.5 | 1.0 | 1.0 |





4.3.2.4 Battery: Click the battery block to enter the battery data display window, click return to return to the previous window, click home page to return to the main page.

| Parameter | Value 1 | Value 2 |
|---------------|---------|---------|
| Voltage (V) : | +240 | -240 |
| Current (A) : | +10 | -10 |
| Batt Status : | Boost | Boost |
| Temp (°C) : | 0.0 | |

| | |
|------------------------|-----|
| Cap Rate (%) : | 100 |
| Backup Time (min) : | 100 |
| Discharge Time (min) : | 100 |

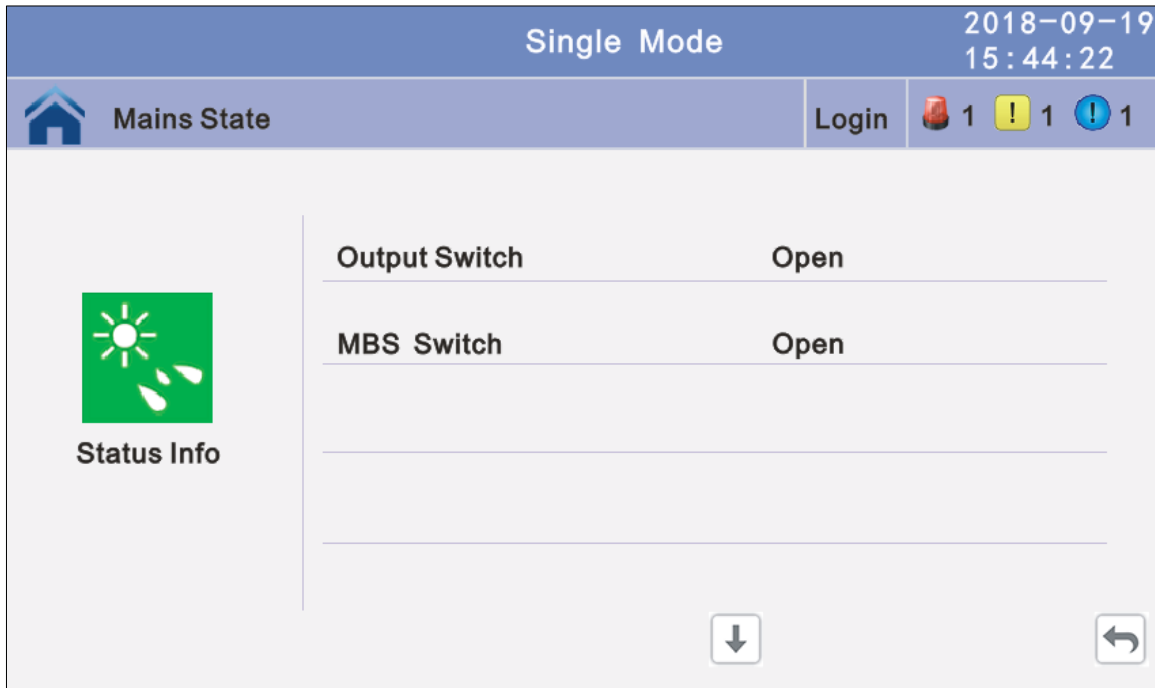
4.3.2.5 Status info: Click the status info block to enter the status data display window, click return to return to the previous window, click home page to return to the main page.



4.3.3 Alarm: View the alarm and history of the UPS, and open or close the buzzer.

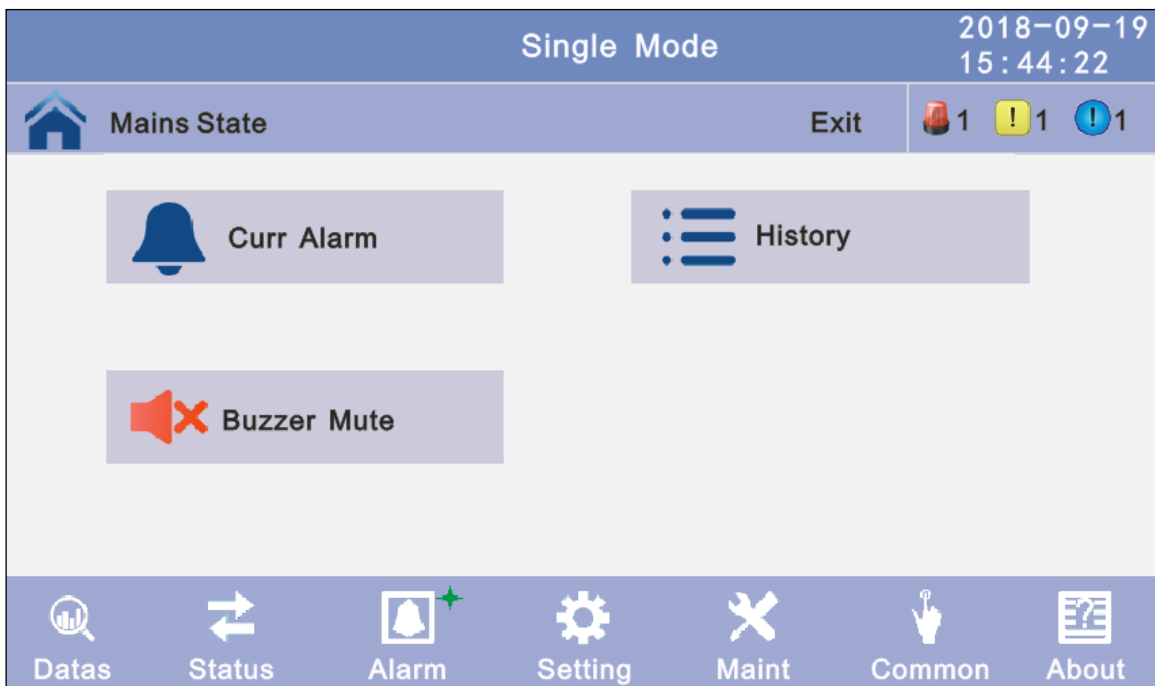

4.3.3.1 Curr Alarm: Click the curr alarm to enter the current alarm display window, click return to return to the previous window, click home page to return to the main page.

| Single Mode | | | | 2018-09-19 |
|-------------|-------|----------------------------------|--------|-------------|
| | | | | 15:44:22 |
| Mains State | | | Login | 🔴 1 ! 1 ! 1 |
| No. | Level | Info | Loc | |
| 001 | ! | 14C-01 ECU Abnormal | ECU 01 | |
| 002 | 🔴 | 01D-01 Power block not connected | ECU 01 | ↑ |
| | | | | ↓ |
| | | | | ↶ |

4.3.3.2 History: Click the history to enter the history recode display window, click return to return to the previous window, click home page to return to the main page.

| Single Mode | | | | | 2018-09-19 |
|-------------|-------|---------------------|--------|------------------------|------------|
| | | | | | 15:44:22 |
| Mains State | | | Login | 🔴 1 ! 1 ! 1 | |
| History | | | | | |
| No. | Level | Info | Loc | Time | |
| 0001 | ! | On Line | System | 2018-06-15 18:12:00 | |
| 0002 | ! | Rectifier Activated | System | 2018-06-15 18:12:00 | ↑ |
| | | | | | ↓ |
| | | | | | ↶ |

4.3.3.3 Buzzer: Click the buzzer mute then the buzzer will mute and the red block will change to green, if the buzzer is on, then click the block buzzer will on and the block will change to red. click return to return to the previous window, click home page to return to the main page.

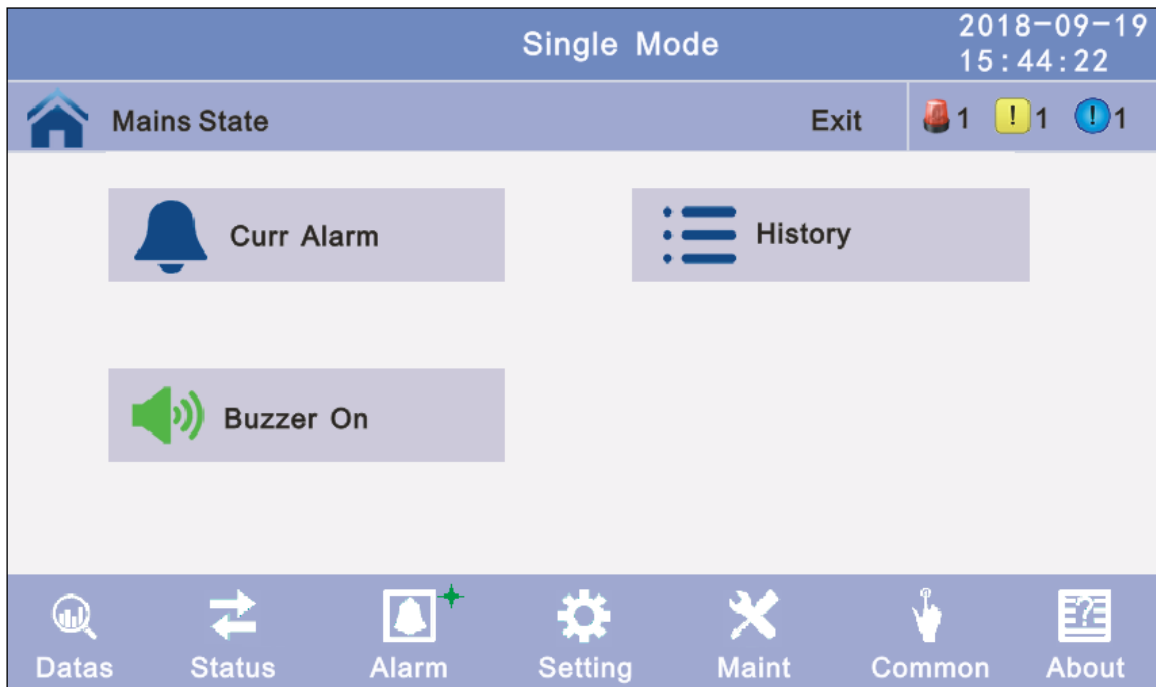
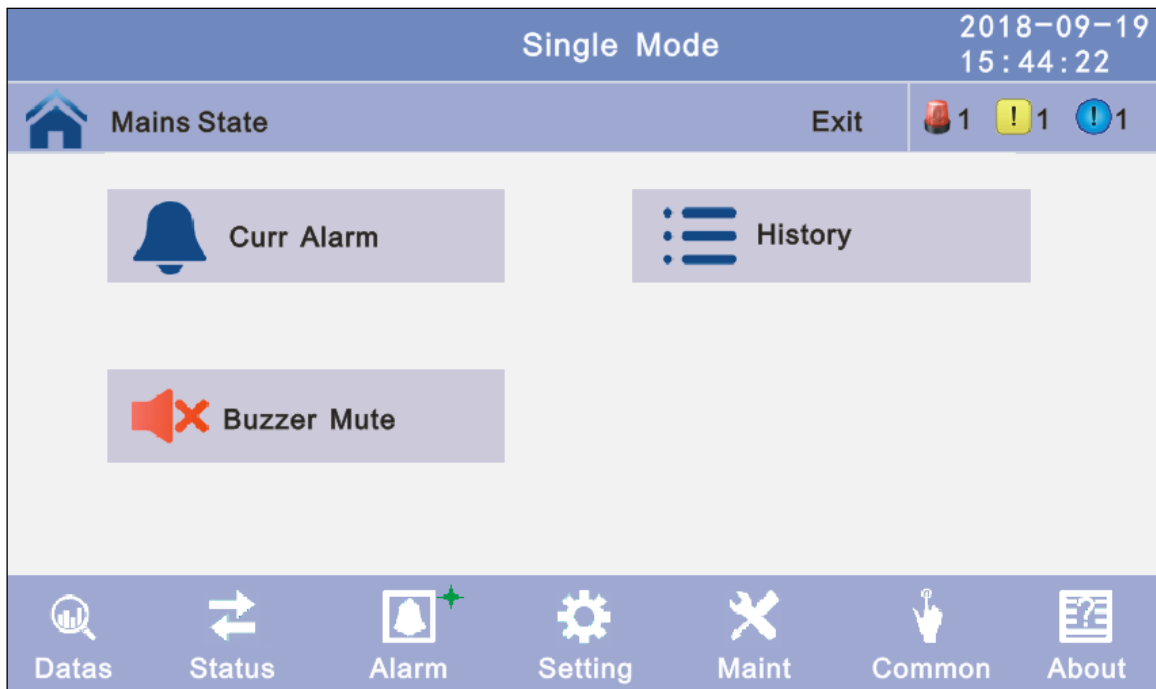

4.3.4 Setting: There are two levels, the basic setting for user settings, advanced setting for technical personnel, please contact the relevant technical personnel to enter advanced settings.



4.3.4.1 Basic Setting: Click basic setting, enter by input the correct password. The user password is "111111".

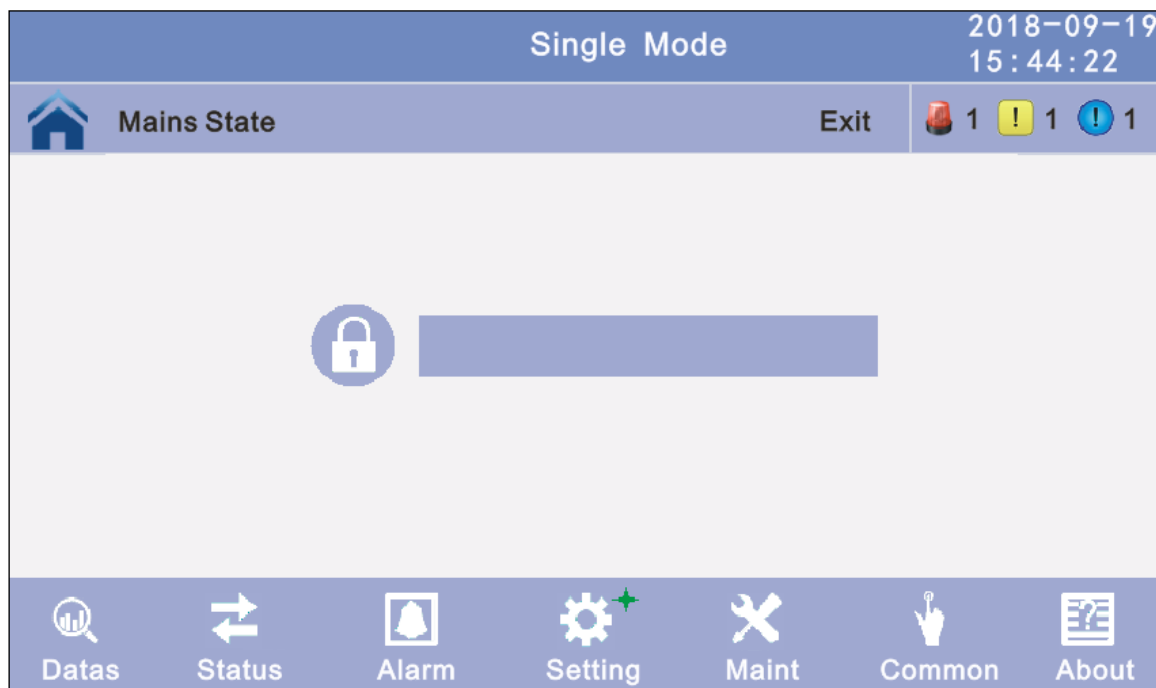

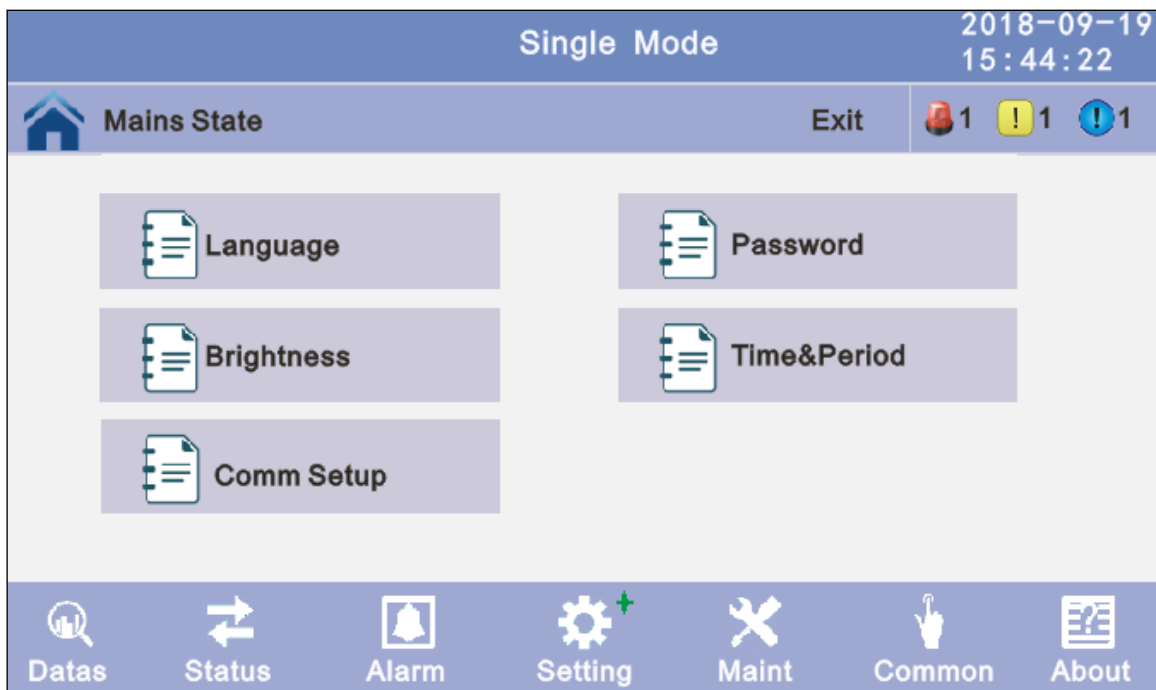
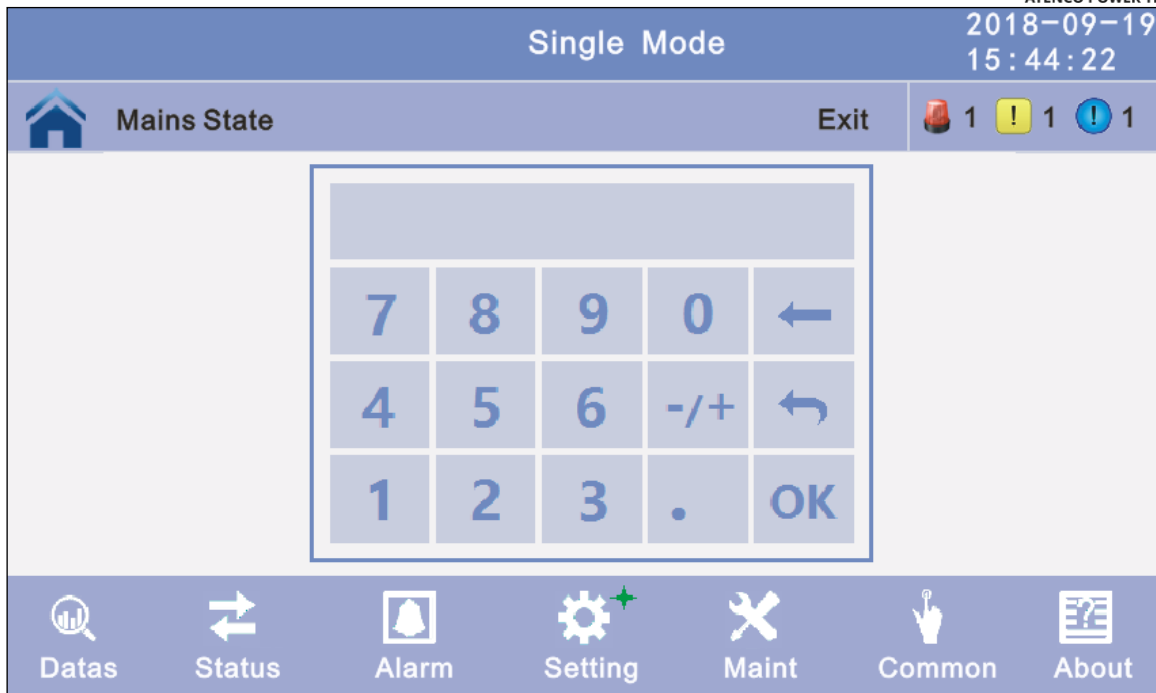

4.3.4.1.1 Language: Click the language block with you want and click the save config block to save. click return to return to the previous window, click home page to return to the main page.



4.3.4.1.2 Password: Click password block enter user password setting page, input old password and new password, then click save confir to save the change. Password format is six number. click return to return to the previous window, click home page to return to the main page.

Password lock time: When LCD is not touched, it needs to re login when the setting value is set, click left or right block to change the value.

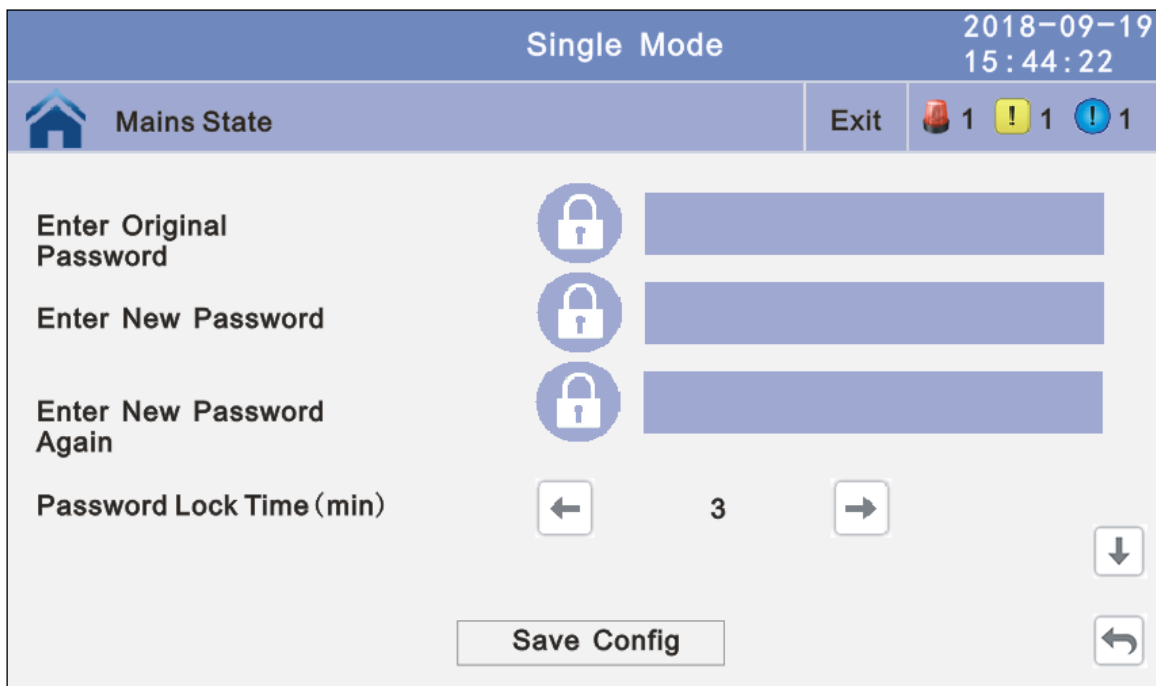

4.3.4.1.3 BrighNess and Backlight time: Click the block to change value. click return to return to the previous window, click home page to return to the main page.

BrighNess: Click the text to input new value and click the save config block to save. Value range is 1~63, default value is 63. Click return to return to the previous window, click home page to return to the main page.

Backlight time: LCD backlight delay time, click the text to input new value and click save config block to save. Value range is 1~255, default value is 60. Click return to return to the previous window, click home page to return to the main page.

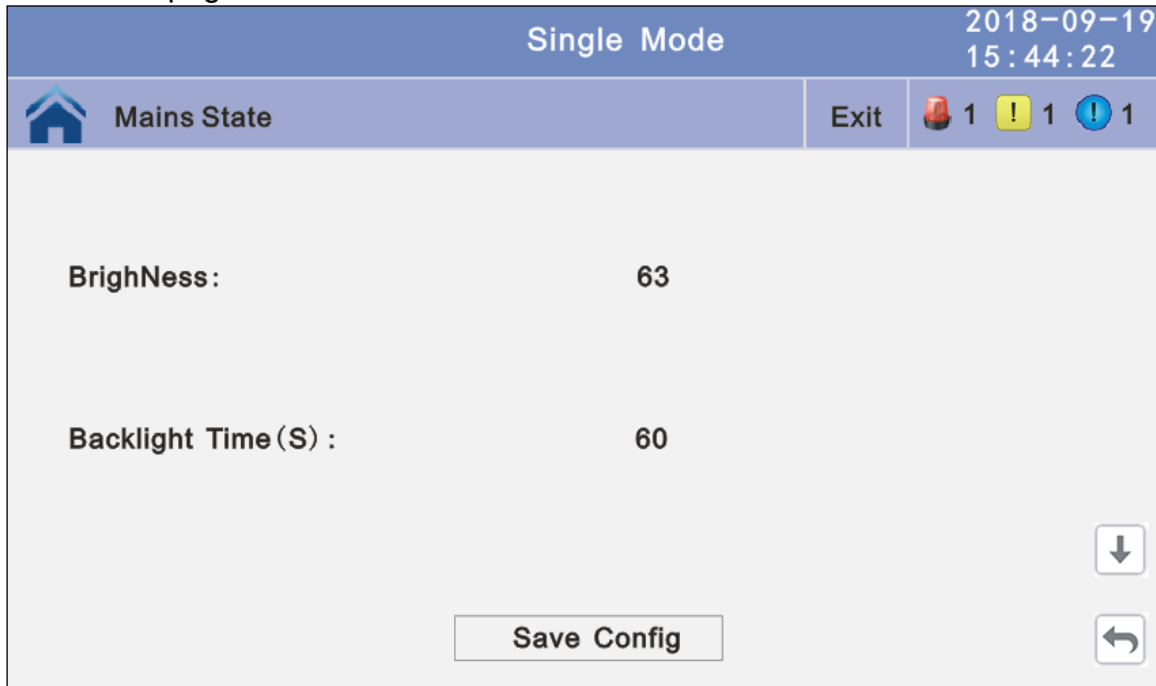

4.3.4.1.4 Date and time setting: Click the text to select other value or input new value and click save config block to save. Click return to return to the previous window, click home page to return to the main page.

Date: current date

Time: current time

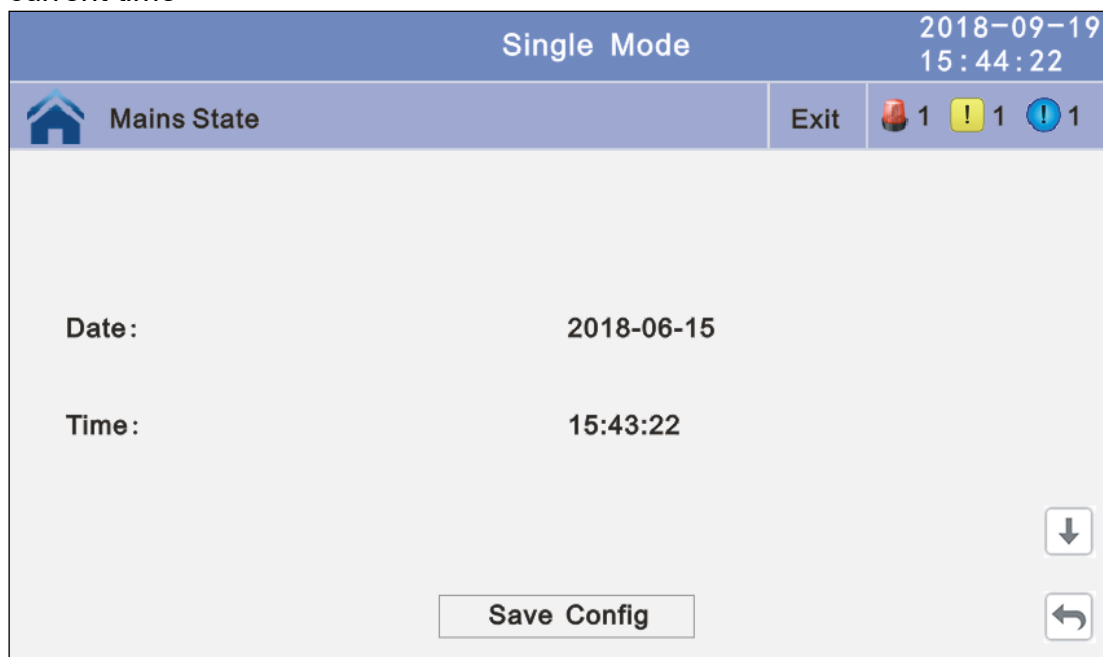

4.3.4.1.5 Communication setting: Click the text to select other value or input new value and click save config block to save. Click return to return to the previous window, click home page to return to the main page.

Rs485 address: UPS communication ID, address range is 1~15, default is 1

Rs485 Baud Rate: baud rate: 2400, 4800, 9600, 14400, 19200, default is 9600



4.3.4.2 Advanced Setting: Click advanced setting, enter by input the correct password. The user password is "191210".

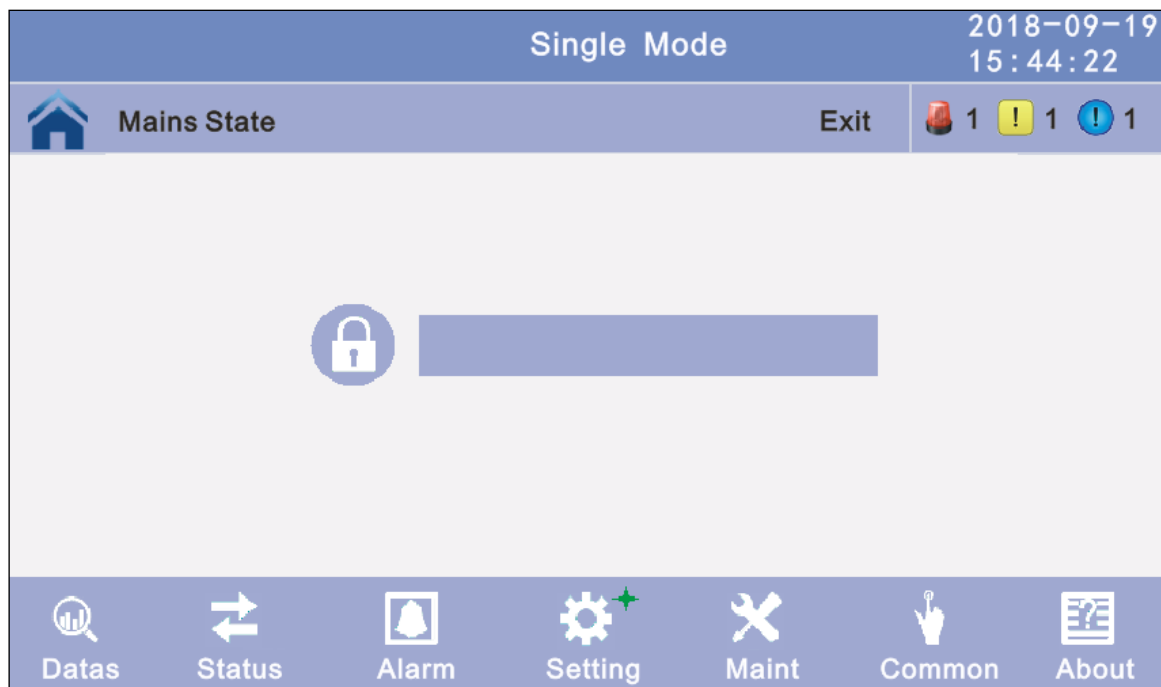

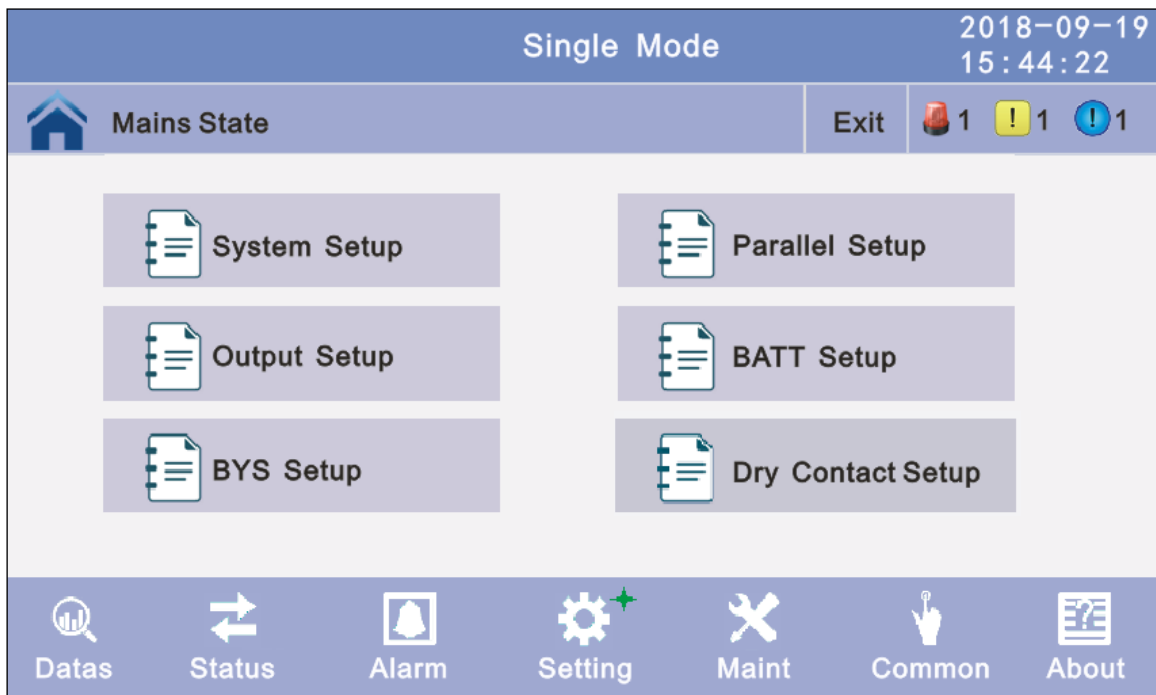
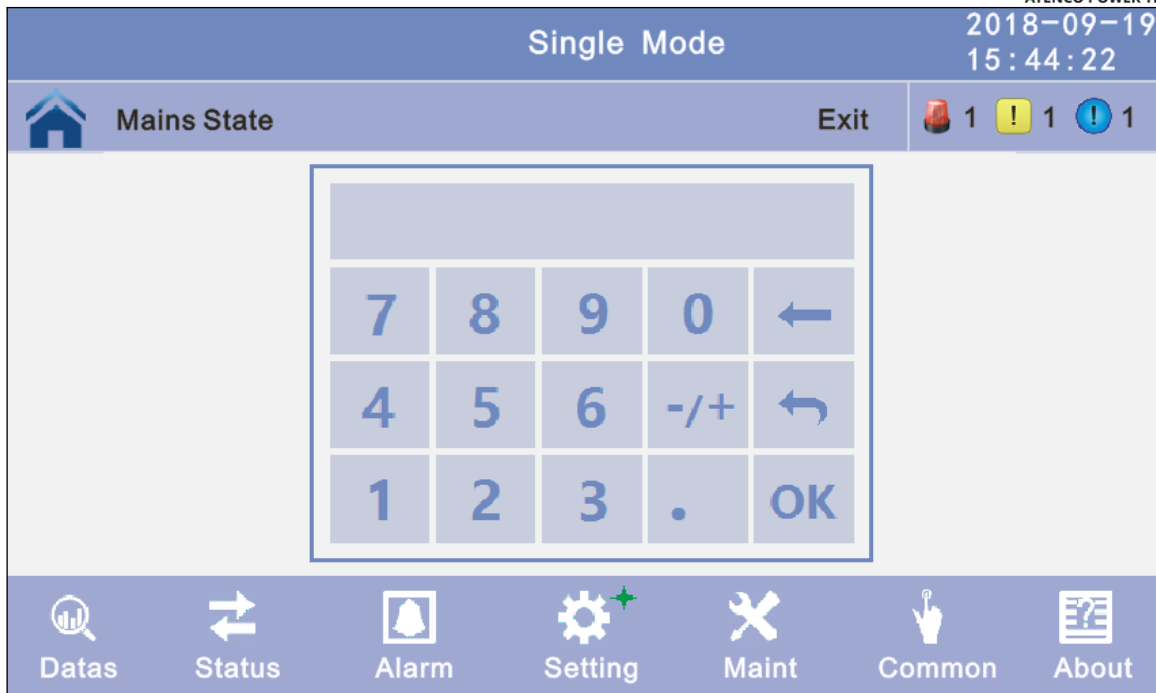

4.3.4.2.1 System setup: Click the text to select other value or input new value and click save config block to save. Click return to return to the previous window, click home page to return to the main page.

Working Mode: Select the work mode of UPS, work mode: Single mode, Parallel mode, ECO mode.

Auto Turn-on: Select the UPS start logic, Enable: UPS start inverter output automatic, Disable: No output.

Aging Load Rate: The value can be 18~100%, default value: 60%



| Single Mode | | 2018-09-19 15:44:22 | |
|---|------|---|---|
|  Mains State | Exit |  1 |  1 |
| Working Mode | ← | Single Mode | → |
| Auto Turn-on | ← | Enable | → |
| Aging Load Rate (%) | | 60 | |
| <input type="button" value="Save Config"/> | | | ↓ |
| | | | ↶ |

Rreq Conv Mode: Frequency conversion mode, enable: output frequency set 50Hz or 60Hz, input frequency is 60Hz or 50Hz, UPS no alarm not battery and bypass abnormal. Default is Disable.

LBS mode: setting value: LBS disable, LBS master, LBS slave. Default is LBS disable.

Float Temp. Compen.: temperature sensor compensation switch, when need to connect battery temperature sensor, please change the value to enable.

Temp Sensor Select: temperature sensor type select. Has tow types: NTC and RS485. NTC for single and short distance. Rs485 for multiple and far distance.

| Single Mode | | 2018-09-19 15:44:22 | |
|---|------|---|---|
|  Mains State | Exit |  1 |  1 |
| Freq Conv Mode | ← | Disable | → |
| LBS Mode | ← | Disable | → |
| Float Temp. Compen. | ← | Disable | → |
| Temp Sensor Select | ← | OFF | → |
| <input type="button" value="Save Config"/> | | | ↑ |
| | | | ↓ |
| | | | ↶ |

Inter Power Walk in: this is enable the UPS to control the interval that each rack transfers from battery mode to normal mode, which reduces the impact on the generator or power grid. The value can be 0~200, default value is 10.

Inter sleep mode: when load less than the software setting value, same parallel rack will turn to standby mode and if the load more than the setting value some rack will turn to inverter mode after setting the sleep mode enable. Default value is disable.



Parallel ID: Parallel operation ID, must modify the ID after set work mode to parallel mode. The value can be 1~6, default value is 1.

Cabinet Paral Basic Units: Parallel cabinet number, must modify the total parallel cabinet number after set work mode to parallel mode. The value can be 2~6, default value is 2.

Cabinet Paral Redunt Units: Parallel redundancy cabinet number, can modify the redundancy cabinet number after set work mode to parallel mode. The value can be 0~5, default value is 0.



Output Freq: Output frequency, The value can be 50Hz or 60Hz.

Output Volt Level: Output voltage level, The value can be 220V, 230V, 240V.

Inverter Volt Adjust: Inverter voltage regulated, The value can be -5%~0~+5%, step is 0.5%, default value: 0.











| Single Mode | | 2018-09-19 15:44:22 | | |
|---|---|---|---|---|
|  Mains State | Exit |  1 |  1 |  1 |
| Output Freq (Hz) |  | 50.0 |  | |
| Output Volt Level (V) |  | 220.0 |  | |
| Inverter Volt Adjust (%) |  | 0.0 |  | |
| <input type="button" value="Save Config"/> | | |  | |

Battery Group: Must modify the number to actual configuration, The value can be 1~8, default value is 1.

Battery number: Must modify the number to actual configuration, The value can be 30~50, default value is 30.

Single Battery Capability: Must modify the value to actual configuration, The value can be 7~2000.

Boost/Float conversion: boost charge and float charge alternate time, The value can be 0~20.

| Single Mode | | 2018-09-19 15:44:22 | | |
|---|---|---|---|---|
|  Mains State | Exit |  1 |  1 |  1 |
| Battery Group |  | 1 |  | |
| Battery Number |  | 36 |  | |
| Single Battery Capability (AH) | | 2000 | | |
| Boost/Float Conversion (Month) | | 0 | |  |
| <input type="button" value="Save Config"/> | | |  | |

Chg.cur.limiting coef.: The charging current limit is a multiple of the battery capacity. The value can be 0.05~0.15, and is 0.1 by default.

Cell float voltage: The float voltage value can be 2.23~2.30 V/cell, and is 2.25 V/cell by default.

Cell boost voltage: The battery equalized voltage value can be 2.30~2.40 V/cell, and is 2.30 V/cell by default.

Aver charging Duration: boost charge time limit, the value can be 1~999min , and is 240 by default.

| Single Mode | | 2018-09-19 15:44:22 | |
|------------------------------|----------|------------------------|------|
| Mains State | Exit | 1 | 1 1 |
| Chg. cur. limiting coef. (C) | ← 0.15 → | | |
| Cell float voltage (V/Cell) | ← 2.25 → | | |
| Cell boost voltage (V/Cell) | ← 2.40 → | | ↑ |
| Aver Charging Duration (min) | 999 | | ↓ |
| Save Config | | | ↶ |

EOD Battery Volt: End of discharge voltage. The value can be 1.60~1.90, and is 1.80 by default.

Float Temp Compen Coeff: modify the voltage of compensation after enable the switch. the value can be 0.001~0.007/cell, and is 0.003 by default.

Boost Charge Setting: Boost charge disable or enable, and is enable by default.

No Battery Warning: can be no warning when no batter after set disable, and is enable by default.

| Single Mode | | 2018-09-19 15:44:22 | |
|-------------------------------------|------------|------------------------|------|
| Mains State | Exit | 1 | 1 1 |
| EOD Battery Volt (V/Cell) | ← 1.80 → | | |
| Float Temp Compen Coef. (V/Cell/°C) | ← 0.003 → | | |
| Boost Charge Setting | ← Enable → | | ↑ |
| No Battery Warning | ← Enable → | | ↓ |
| Save Config | | | ↶ |

Bypass Volt Prot Lower Limit: When the difference between the bypass voltage and the rated voltage exceeds the lower threshold for the bypass voltage, the system determines that the bypass voltage is abnormal and that the bypass is unavailable. The value can be -10%, -15%, -20%, -30%, -45%,. The default value is -45%.

Bypass Volt Prot Limit: When the difference between the bypass voltage and the rated voltage exceeds the upper threshold for the bypass voltage, the system determines that the bypass voltage is not normal and that the bypass is unavailable.

NOTE:















When the voltage level is 380 V, the value range is 10%, 15%, 20%, and 25% (default).

When the voltage level is 400 V, the value range is 10%, 15%, and 20% (default).

When the voltage level is 415 V, the value range is 10% and 15%(default).

Bypass Freq Tracking Range: When the difference between the bypass input frequency and the rated frequency is greater than this value, the system determines that the bypass frequency is not normal, and that the bypass is unavailable. The value range is 1%, 2%, 4%, 5%, 10%(default).

Bypass rate tracking rate: Inverter frequency tracking to bypass frequency rate. The value range is 0.5~2, and is 1 by default.

| Single Mode | | 2018-09-19 15:44:22 | |
|---|---|---|---|
|  Mains State | Exit |  1 |  1  1 |
| Bypass Volt Prot Lower Limit (%) |  | -45 |  |
| Bypass Volt Prot Limit (%) |  | 25 |  |
| Bypass Freq Tracking Range (%) |  | 10 |  |
| Bypass Tracking Rate (Hz/s) |  | 1.0 |   |
| <input type="button" value="Save Config"/> | | |  |

Power Supply upon bypass Over Temp: Specifies whether to start bypass mode when over temperature occurs. The default value is Enable.

Bypass Switches Limit: Cross currents occur during the transfer between bypass mode and normal mode, which impacts the system. This parameter specifies the number of transfers between bypass mode and normal mode within 1 hour, which ensures system security. The value can be 3 to 10, and is 10 by default.

EPO transfers to BYP: Specifies whether to start bypass mode when EPO occurs. The default value is Enable.

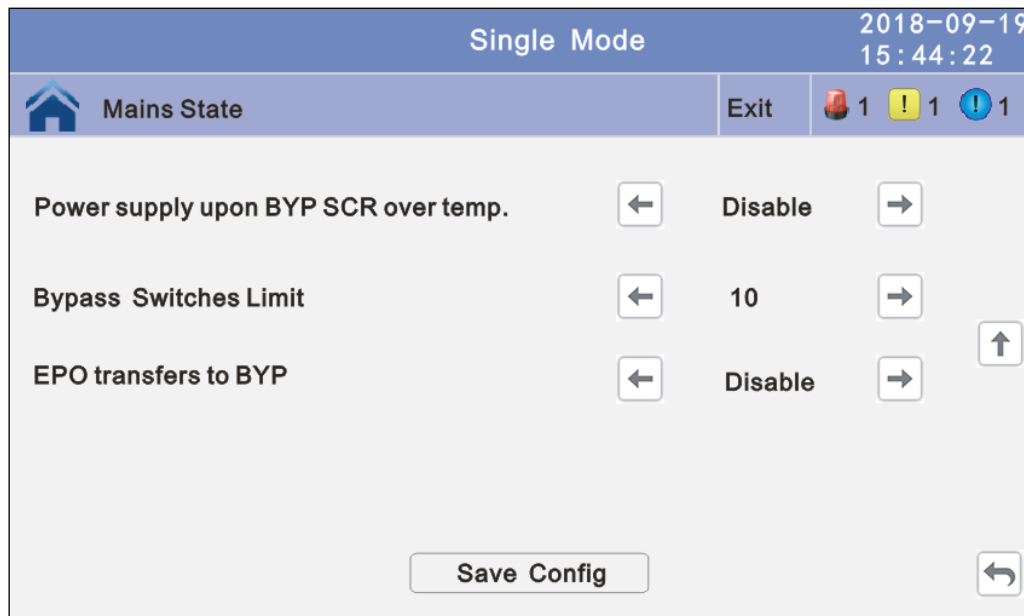

Battery Abnormal BCB trip(DRV): Enable or disable BCB trip single output. The default value is Disable.

Bypass Feedback: Enable or disable bypass feedback output. The default value is Disable.

External Maint. breaker: Enable or disable external maintenance breaker connection detection. The default value is Disable.

Battery Switch(BAT): Enable or disable battery breaker connection detection. The default value is Disable.

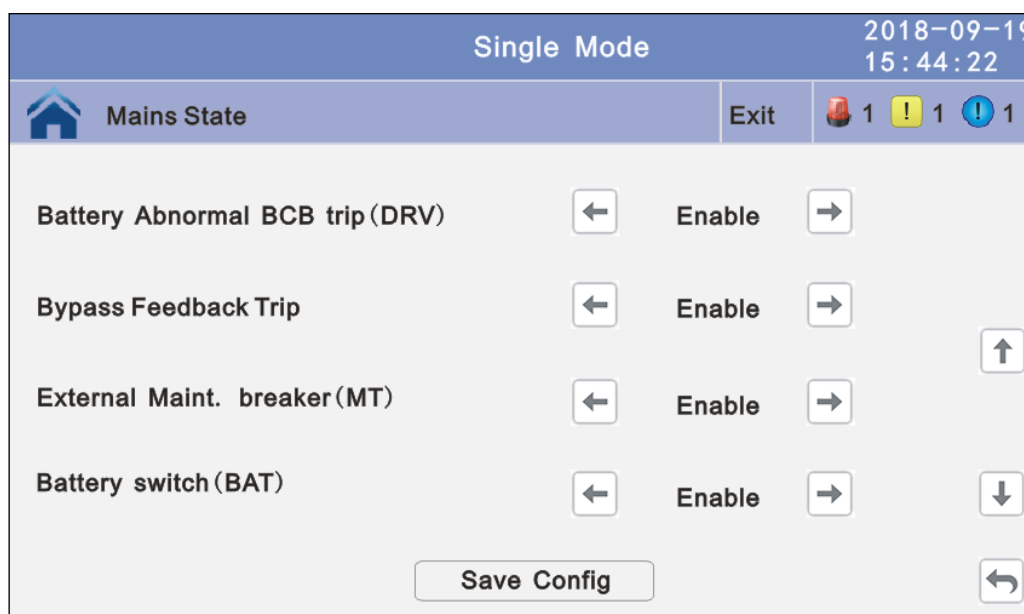

4.3.5 Maint: Software update, Touch correction, history download and battery self-test.

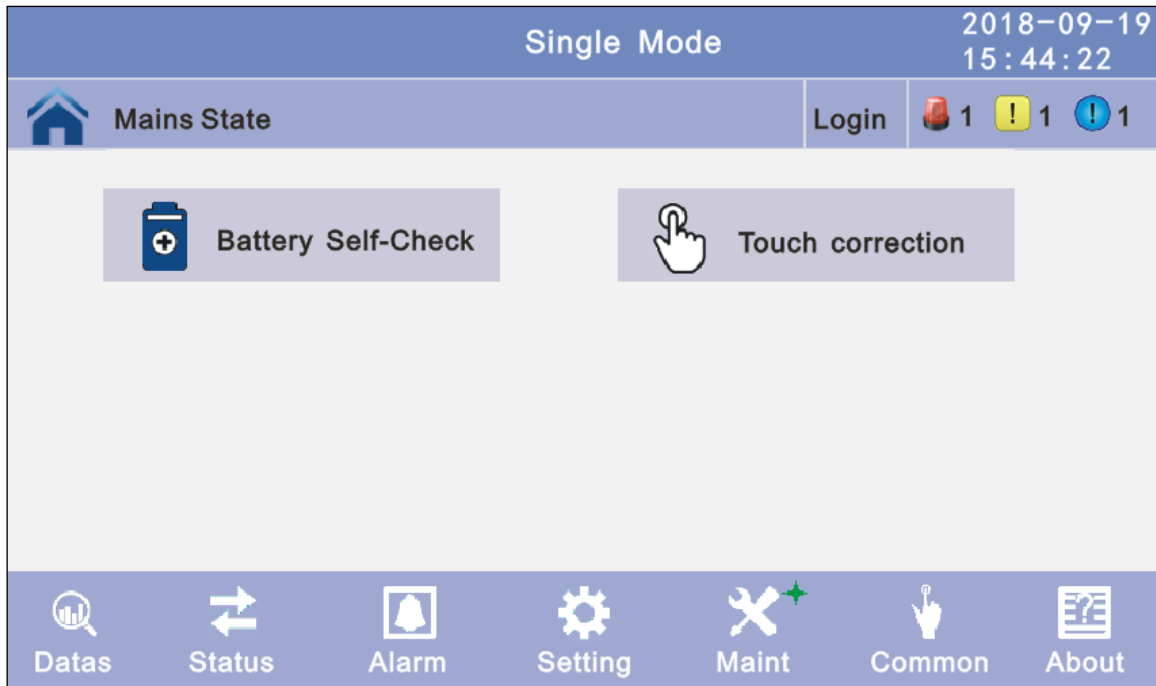

4.3.5.1 Battery Self-Check: can select check by Timing Daily, Timing Weekly, Cycle mode. The default value is Timing Self-Check Close.

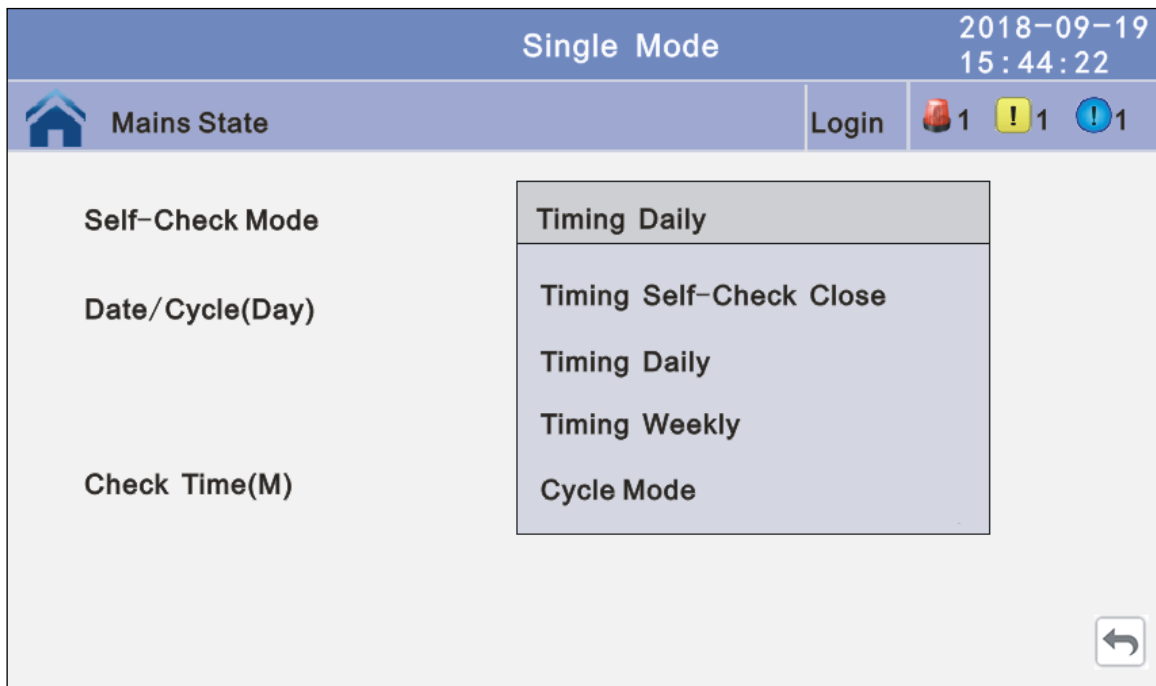

4.3.5.2.1 Timing Daily: modify the check date, time and check time (10S (default), 10min, EOD).

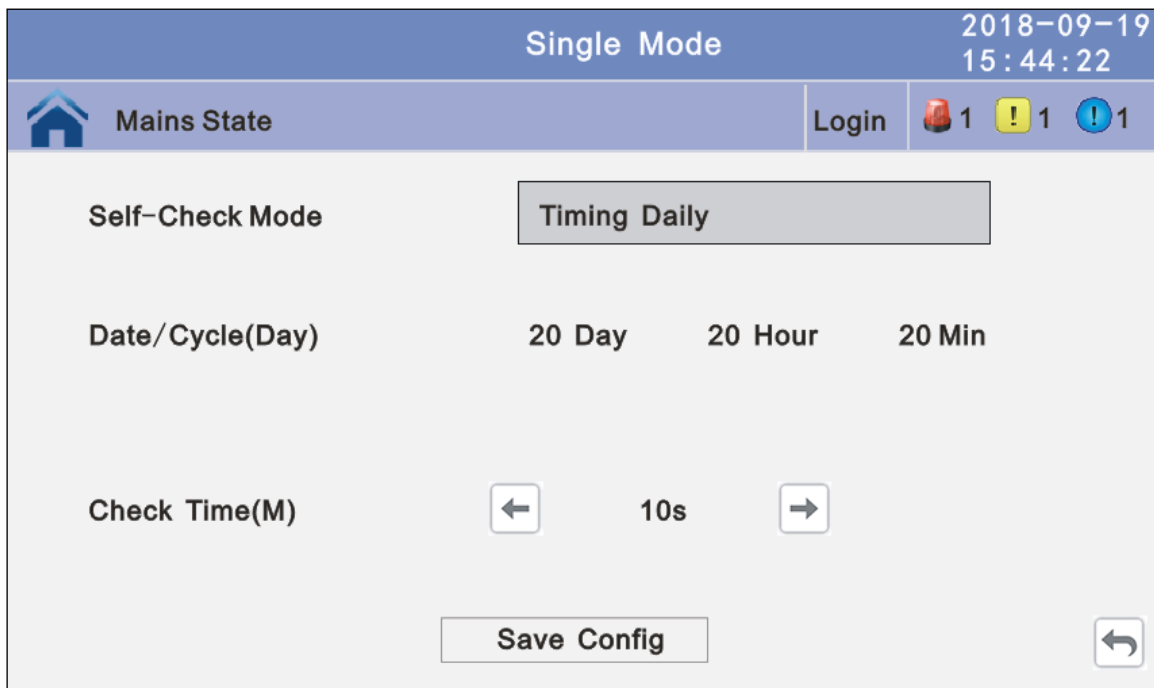

Single Mode 2018-09-19 15:44:22

Mains State Login 1 1 1

Self-Check Mode Timing Daily

Date/Cycle(Day) 20 Day 20 Hour 20 Min

Check Time(M) ← 10s →

Save Config ↩

4.3.5.2.2 Timing Weekly: modify the check date, time and check time (10S (default), 10min, EOD).

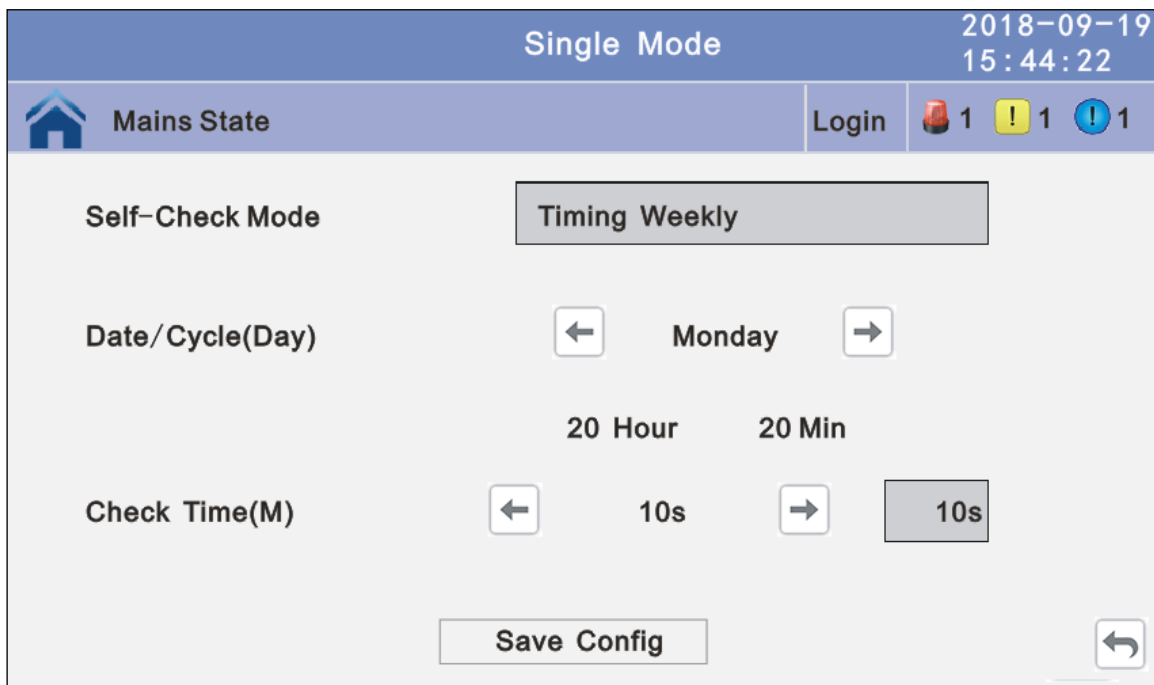

Single Mode 2018-09-19 15:44:22

Mains State Login 1 1 1

Self-Check Mode Timing Weekly

Date/Cycle(Day) ← Monday →

20 Hour 20 Min

Check Time(M) ← 10s → 10s

Save Config ↩

4.3.5.2.3 Timing Cycle mode: modify the cycle date and check time (10S (default), 10min, EOD).

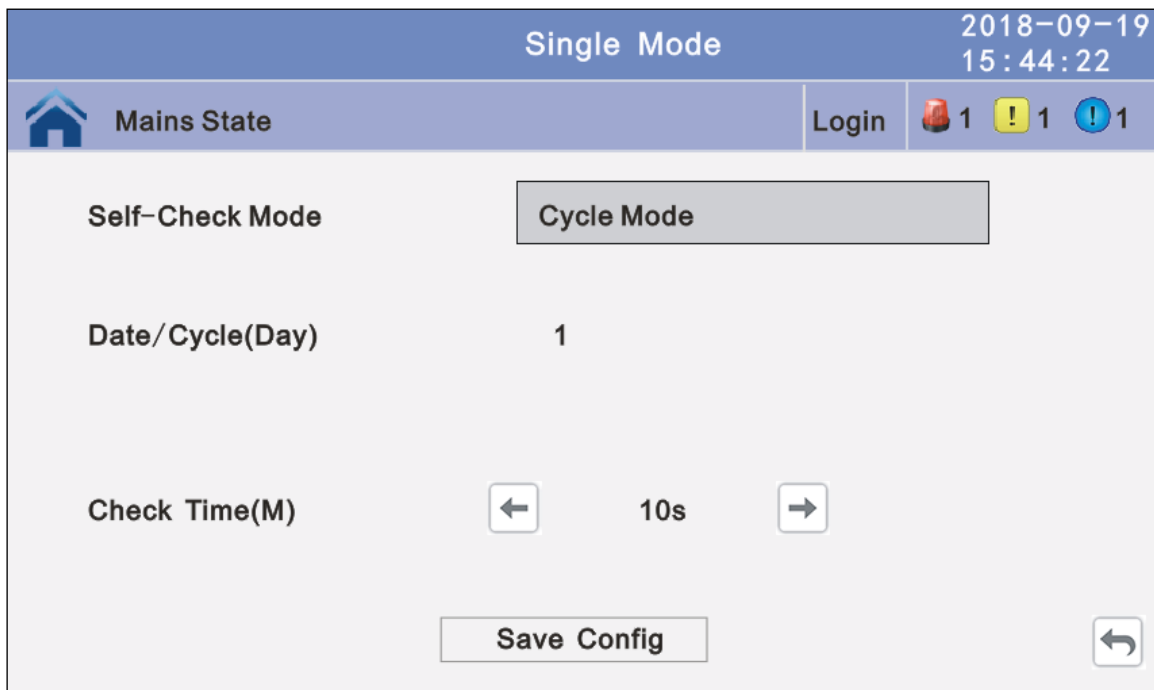

4.3.6 Common: INV ON/OFF, Battery test and Fault clear.

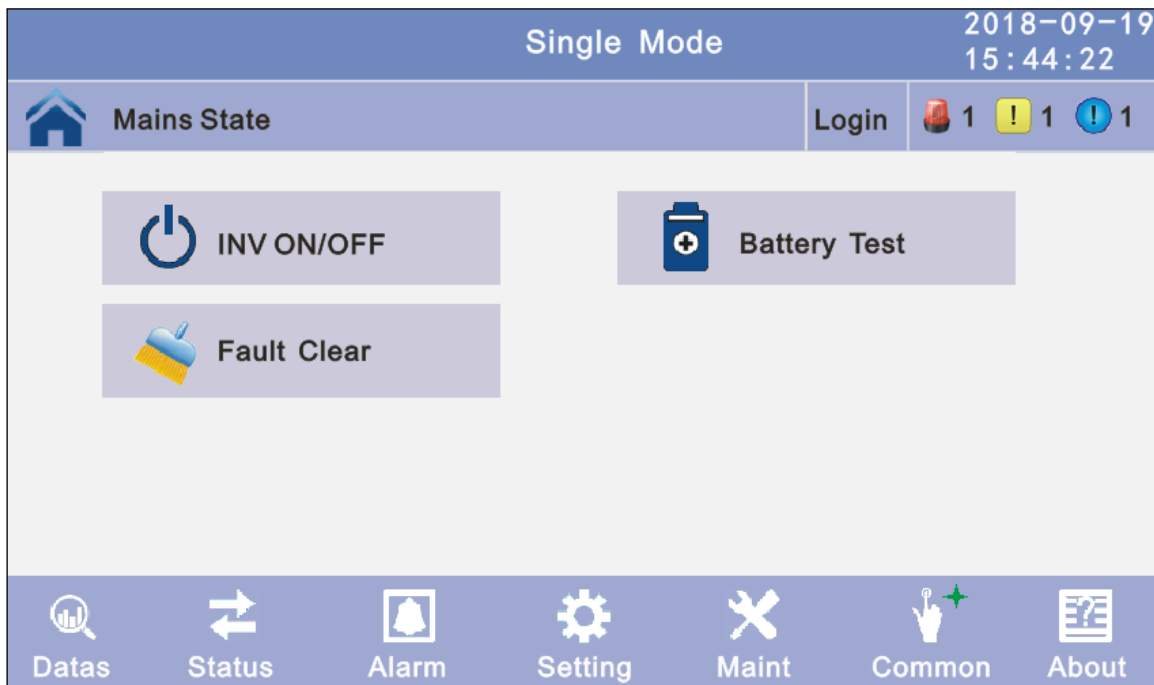

4.3.6.1 INV ON/OFF

Single OFF: Inverter OFF location UPS

Single ON: Inverter ON location UPS

Parallel OFF: Inverter OFF all parallel UPSs

Parallel ON: Inverter ON all parallel UPSs

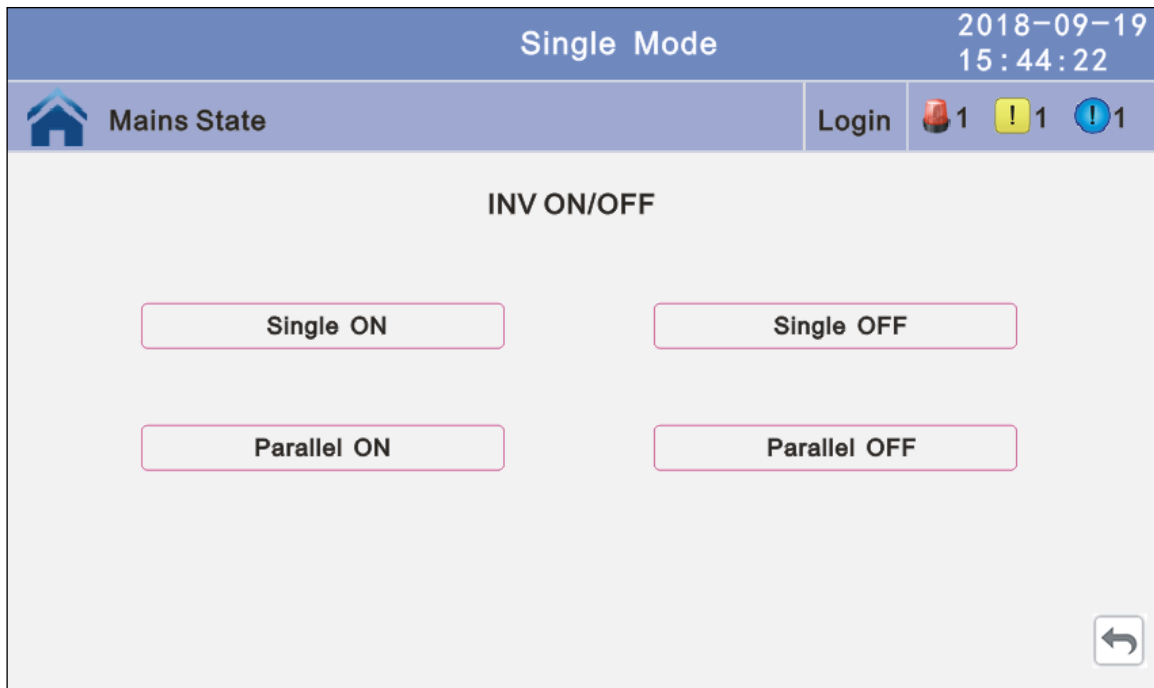

4.3.6.2 Battery Test

10S: battery test for 10s

10min: battery test for 10min

EOD: battery test to EOD

-10%: battery test down 10% capability.

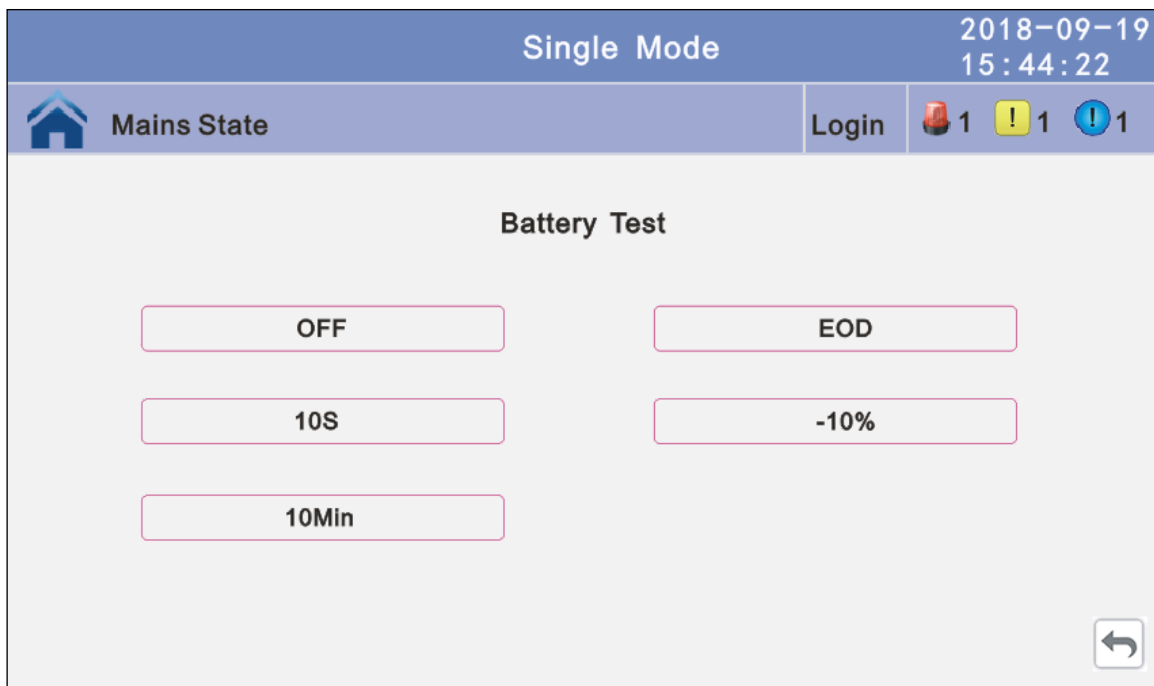

4.3.6.3 Fault clear: Clear the current fault (not for all faults).



4.3.7 About: check the software version

4.3.7.1 Monitor and LCD software version

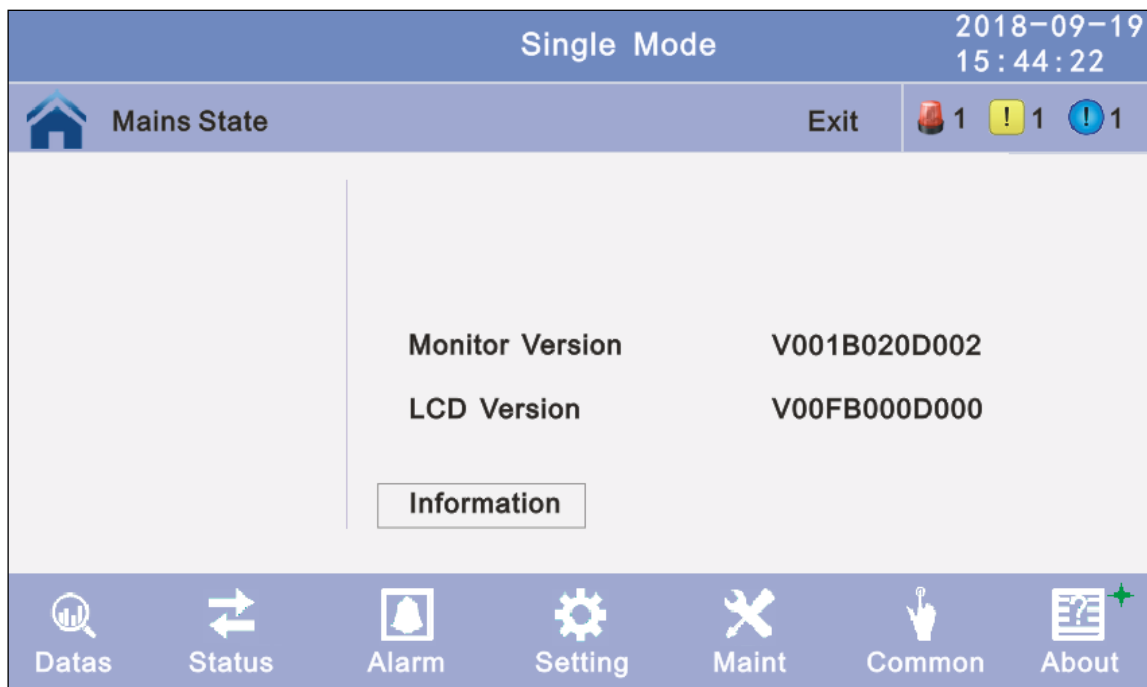

4.4 Display Messages/Troubleshooting

This section lists the event and alarm messages that the UPS might display. The messages are listed in alphabetical order. This section is listed with each alarm message to help you troubleshoot problems.

Display messages

Operational Status and Mode(s)

| No. | Information stand for | LED | | | |
|-----|--------------------------|-------------------|-------------------|-------------------|-------------------|
| | | Fault | Bypass | Battery | Inverter |
| 1 | Initialized | EXTINGUISH | EXTINGUISH | EXTINGUISH | EXTINGUISH |
| 2 | Standby Mode | EXTINGUISH | EXTINGUISH | X | EXTINGUISH |
| 3 | No Output | EXTINGUISH | EXTINGUISH | X | EXTINGUISH |
| 4 | Bypass Mode | EXTINGUISH | LIGHT | X | EXTINGUISH |
| 5 | Utility Mode | EXTINGUISH | EXTINGUISH | X | LIGHT |
| 6 | Battery Mode | EXTINGUISH | EXTINGUISH | LIGHT | EXTINGUISH |
| 7 | Battery Self-diagnostics | EXTINGUISH | EXTINGUISH | LIGHT | EXTINGUISH |
| 8 | Inverter is starting up | EXTINGUISH | X | X | EXTINGUISH |
| 9 | ECO Mode | EXTINGUISH | X | X | X |
| 10 | EPO Mode | LIGHT | EXTINGUISH | X | EXTINGUISH |
| 11 | Maintenance Bypass Mode | EXTINGUISH | EXTINGUISH | EXTINGUISH | EXTINGUISH |
| 12 | Fault Mode | LIGHT | X | X | X |

CAUTION: "X" means it is determined by other conditions

Fault Information

| No | Fault Cord | UPS Alarm Warning | Buzzer | LED |
|----|------------|-----------------------|--------------------|--------------------|
| 1 | 002 | REC Over Temperature | Twice per second | Fault LED lit |
| 2 | 003 | REC par. cable Fault | Twice per second | Fault LED lit |
| 3 | 004 | REC Over Current | Beep continuously | Fault LED lit |
| 4 | 005 | REC Power Fault | Beep continuously | Fault LED lit |
| 5 | 007 | Input SCR Fault | Beep continuously | Fault LED lit |
| 6 | 00A | Battery SCR Fault | Beep continuously | Fault LED lit |
| 7 | 00C | Charge SCR Fault | Beep continuously | Fault LED lit |
| 8 | 00E | Fan Fault | Beep continuously | Fault LED lit |
| 9 | 011 | Fan Power fault | Beep continuously | Fault LED lit |
| 10 | 012 | Charger Over Temp. | Beep continuously | Fault LED lit |
| 11 | 013 | Soft Start Failed | Beep continuously | Fault LED lit |
| 12 | 014 | BAT Charger Fault | Beep continuously | Fault LED lit |
| 13 | 016 | REC Comm. Fault | Once per 2 seconds | Fault LED blinking |
| 14 | 019 | REC Initializes Fault | Beep continuously | Fault LED lit |
| 15 | 01D | Unit insert fault | Once per 2 seconds | Fault LED lit |
| 16 | 063 | | Once per 2 seconds | Fault LED lit |
| 17 | 01E | Rectifier Fault | Beep continuously | Fault LED lit |
| 18 | 041 | Inverter Fault | Beep continuously | Fault LED lit |
| 19 | 044 | INV IGBT SHORT | Beep continuously | Fault LED lit |

| No | Fault Cord | UPS Alarm Warning | Buzzer | LED |
|----|------------|-----------------------|--------------------|--------------------|
| 20 | 047 | Inverter relay Short | Beep continuously | Fault LED lit |
| 21 | 04A | Inverter relay Broken | Beep continuously | Fault LED lit |
| 22 | 04D | INV par. cable Fault | Twice per second | Fault LED lit |
| 23 | 051 | Output Short Circuit | Once per second | Fault LED blinking |
| 24 | 054 | INV Comm. Fault | Once per 2 seconds | Fault LED blinking |
| 25 | 057 | INV Initializes Fault | Beep continuously | Fault LED lit |
| 26 | 05A | INV self-test Fault | Beep continuously | Fault LED lit |
| 27 | 05E | DC Component Fault | Once per 2 seconds | Fault LED lit |
| 28 | 061 | DC bus abnormal | Beep continuously | Fault LED lit |
| 29 | 064 | INV DSP Power Fault | Beep continuously | Fault LED lit |
| 30 | 067 | INV Over Temperature | Twice per second | Fault LED lit |
| 31 | 068 | Load Sharing Fault | Twice per second | Fault LED lit |
| 32 | 06A | Cabinet mode Fault | Beep continuously | Fault LED lit |
| 33 | 06B | Fuse Broken | Beep continuously | Fault LED lit |
| 34 | 081 | Par. cable Fault | Twice per second | Fault LED lit |
| 35 | 086 | ECU Insert Fault | Once per 2 seconds | Fault LED lit |
| 36 | 088 | ECU Power Fault | Beep continuously | Fault LED lit |
| 37 | 08B | ECU Comm. Fault | Beep continuously | Fault LED lit |
| 38 | 08D | ECU Initializes Fault | Once per 2 seconds | Fault LED blinking |
| 39 | 091 | Bypass SCR Broken | Beep continuously | Fault LED lit |
| 40 | 0C2 | | Beep continuously | Fault LED lit |
| 41 | 094 | Bypass SCR short | Beep continuously | Fault LED lit |
| 42 | 0C5 | | Beep continuously | Fault LED lit |
| 43 | 097 | BPS Over Temperature | Beep continuously | Fault LED lit |
| 44 | 0CF | | Beep continuously | Fault LED lit |
| 45 | 09A | Output CT Reverse | Beep continuously | Fault LED lit |
| 46 | 09D | Bypass Feedback Fault | Beep continuously | Fault LED lit |

Alarm Information

| No | Alarm Cord | UPS Alarm Warning | Buzzer | LED |
|----|------------|----------------------|--------------------|-----------------------|
| 1 | 103 | Battery Over Voltage | Once per second | BATTERY LED blinking |
| 2 | 104 | BAT Low Pre-warning | Once per second | BATTERY LED blinking |
| 3 | 105 | Battery Reverse | Twice per second | BATTERY LED blinking |
| 4 | 106 | Battery EOD | Once per second | BATTERY LED blinking |
| 5 | 107 | Battery Voltage low | Once per second | BATTERY LED blinking |
| 6 | 108 | No Battery | Once per second | BATTERY LED blinking |
| 7 | 109 | Input Phase Reverse | Once per second | INVERTER LED blinking |
| 8 | 10A | Input N-Line lost | Twice per second | INVERTER LED blinking |
| 9 | 10B | Mains Freq. Abnormal | Once per 2 seconds | INVERTER LED blinking |
| 10 | 10C | Mains Volt. Abnormal | Once per 2 seconds | INVERTER LED blinking |
| 11 | 10D | REC Comm. Error | Once per 2 seconds | INVERTER LED blinking |
| 12 | 10E | Mains input lost | Once per 2 seconds | |

| No | Alarm Cord | UPS Alarm Warning | Buzzer | LED |
|----|------------|-------------------------|--------------------|-----------------------|
| 13 | 10F | Set Data Err. | Once per 2 seconds | FAULT LED blinking |
| 14 | 121 | INV Par. cable abnormal | Once per 2 seconds | FAULT LED blinking |
| 15 | 125 | INV Overload | Once per 2 seconds | INVERTER LED blinking |
| 16 | 126 | INV not synchronized | Beep continuously | INVERTER LED blinking |
| 17 | 12A | INV Set Data Err | Once per 2 seconds | FAULT LED blinking |
| 18 | 129 | INV Comm. Error | Once per 2 seconds | FAULT LED blinking |
| 19 | 141 | Bypass Switch to Num | Once per 2 seconds | BYPASS LED blinking |
| 20 | 142 | Unit quantity mismatch | Once per 2 seconds | FAULT LED blinking |
| 21 | 143 | Parallel Overload | Once per 2 seconds | INVERTER LED blinking |
| 22 | 144 | Bypass Overload | Once per 2 seconds | BYPASS LED blinking |
| 23 | 145 | Maint. Switch Misuse | Once per 2 seconds | FAULT LED blinking |
| 24 | 146 | ECU Comm. Error | Once per 2 seconds | FAULT LED blinking |
| 25 | 147 | Par. cable abnormal | Once per 2 seconds | FAULT LED blinking |
| 26 | 14B | ECU Par. cable abnormal | Once per 2 seconds | FAULT LED blinking |
| 27 | 14C | ECU Abnormal | Once per 2 seconds | FAULT LED blinking |
| 28 | 14E | BPS Phase Reversed | Once per second | BYPASS LED blinking |
| 29 | 162 | | Once per second | BYPASS LED blinking |
| 30 | 14F | BPS Unable To Trace | Once per 2 seconds | BYPASS LED blinking |
| 31 | 163 | | Once per 2 seconds | BYPASS LED blinking |
| 32 | 150 | BPS Not Available | Once per second | BYPASS LED blinking |
| 33 | 164 | | Once per second | BYPASS LED blinking |
| 34 | 151 | Ecu Set Data Err | Once per 2 seconds | FAULT LED blinking |

4.5 Options

SNMP card: internal SNMP / external SNMP optional

- ◆ Loosen the 2 torque screws (on each side of the card).
- ◆ Carefully pull out the card. Reverse the procedure for re-installation

The slot called SNMP supports the MEGAtec protocol. We advise that NetAgent II-3 port is also a tool to remotely monitor and manage any UPS system

NetAgent II-3Ports supports the Modem Dial-in (PPP) function to enable the remote control via the internet when the network is unavailable.

In addition to the features of a standard NetAgent Mini, NetAgent II has the option to add NetFeeler Lite to detect temperature, humidity, smoke and security sensors. Thus, making NetAgent II a versatile management tool. NetAgent II also supports multiple languages and is setup for web-based auto language detection.

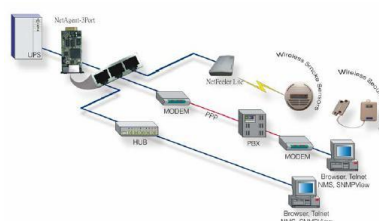

Typical topology of the UPS Network Management

Relay card

A 10-pin terminal is supported to offer the signals of Bypass, Utility Failure, Inverter On, Battery Low, UPS fault, UPS Alarm, and UPS Shutdown.

The relay communication card contains six dry contact outputs and one dry input. The inputs and outputs are factory programmed according to functions listed in the table

Table: Relay Contacts (communication card)

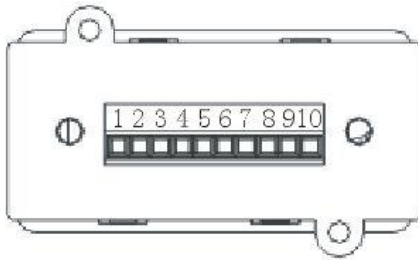

| Port | | Function |
|------|--------|-----------------|
| 1 | Output | Utility Failure |
| 2 | | / |
| 3 | | Battery Low |
| 4 | | On Bypass |
| 5 | | UPS Fault |
| 6 | | Inverter On |
| 7 | | UPS Alarm |
| 8 | COM | |
| 9 | Input | ON |
| 10 | | OFF |



CAUTION!

The output contacts numbers for a second relay board installed will be 1 to 7. Contacts are NO (normally open) type.



Appendix 1 Specifications

| MODEL | 50kVA | 60kVA | 80kVA | 100kVA | 120kVA | 150kVA | 160kVA | 180kVA | 200kVA |
|---|---|------------|------------|------------------|--------------|--------------|--------------|--------------|---|
| Capacity (VA/Watts) | 50k 50k | 60k 60k | 80k 80k | 100k 100k | 120k 120k | 150k 150k | 160k 160k | 180k 180k | 200k 200k |
| INPUT | | | | | | | | | |
| Nominal voltage | 380/400/415Vac, (3Ph+N+PE) | | | | | | | | |
| Operating voltage range | 138~485Vac | | | | | | | | |
| Operating frequency range | 40Hz-70Hz | | | | | | | | |
| Power factor | ≥0.99 | | | | | | | | |
| Harmonic distortion (THDi) | ≤3% (100%non-linear load) | | | | | | | | |
| Bypass voltage range | 220Vac Max.voltage: +25%(optional +10%,+15%,+20%) 230Vac Max.voltage: +20%(optional +10%,+15%) 240Vac Max.voltage: +15%(optional +10%) Min. voltage: -45% (optional -20%,-30%) Frequency synchronize tracing range: ±10% | | | | | | | | |
| Generator input | Support | | | | | | | | |
| OUTPUT | | | | | | | | | |
| Output voltage | 380/400/415Vac (3Ph+N+PE) | | | | | | | | |
| Voltage regulation | ±1% | | | | | | | | |
| Power factor | 1.0 | | | | | | | | |
| Output frequency | 1.Line Mode: synchronize with input; when input frequency >±10% (±1%/±2%/±4%/±5% optional) 2.Battery Mode:50/60*(1±0.02%)Hz | | | | | | | | |
| Crest factor | 3:1 | | | | | | | | |
| Harmonic distortion (THD) | ≤2% with linear load ≤4% with non linear load | | | | | | | | |
| Efficiency | 95.5% | | | | | | | | |
| BATTERY | | | | | | | | | |
| Battery voltage | Optional Voltage: ±180/±192/±204/±216/±228/±240/±252/±264/±276/±288/±300Vdc(30/32/34/36/38/40/ 42/44/46/48/50pcs optional) 360Vdc~600Vdc (30~50 pcs, 30 pcs define, 36~50 pcs no power derating; 32-34 pcs output power factor 0.9;30 pcs output power factor 0.8;) | | | | | | | | |
| Charge Current(A) (charge current can be set according to battery capacity installed) | Max. current 20A | | | Max. current 40A | | | | | Max. current 60A |
| SYSTEM FEATURES | | | | | | | | | |
| Transfer time | Utility to Battery : 0ms; Utility to bypass: 0ms | | | | | | | | |
| Overload | Load≤110%: last 60min,≤125%: last 10min,≤150%: last 1min | | | | | | | | Load≤110%: last 60min,≤125% : last 1min,≤150%: last 1.2s |
| Alarm | Overload, utility abnormal, UPS fault, battery low, etc. | | | | | | | | |
| Backfeed | Support | | | | | | | | |

| | | | | | | | | | |
|-----------------------|--|-------|-------|--------------|-------|-------|-------|-------|-------|
| Protection | Short circuit, overload, over temperature, battery low, fan fault alarm. | | | | | | | | |
| Communication | USB,RS232, RS485, Parallel port, REPO port, LBS port, Backfeed port, Intelligent slot, SNMP card (optional), Relay card (optional) | | | | | | | | |
| ENVIRONMENTAL | | | | | | | | | |
| Operating temperature | 0°C~40°C | | | | | | | | |
| Storage temperature | -25°C~55°C(no battery) | | | | | | | | |
| Humidity range | 0~95% (non condensing) | | | | | | | | |
| Altitude | < 1500m.When>1500m,lower the rated power for use | | | | | | | | |
| Noise level | <58dB | <60dB | <62dB | <63dB | <65dB | <66dB | <66dB | <68dB | <68dB |
| PHYSICAL | | | | | | | | | |
| Dimension D×W×H (mm) | 828x250x868 | | | 850x442x1200 | | | | | |
| Net weight (kg) | 80 | 83 | 154 | 161 | 165 | 190 | 200 | 230 | 232 |
| STANDARDS | | | | | | | | | |
| Safety | IEC/EN62040-1,IEC/EN60950-1 | | | | | | | | |
| EMC | IEC/EN62040-3,IEC61000-4-2,IEC61000-4-3,IEC61000-4-4,IEC61000-4-5,IEC61000-4-6,IEC61000-4-8 | | | | | | | | |

Appendix 2 Problems and Solution

In case the UPS cannot work normally, it might be wrong in installation, wiring or operation. Please check these aspects first. If all these aspects are checked without any problem, please consult with local agent right away and provide below information.

(1) Product model name and serial number.

(2) Try to describe the fault with more details, such as LCD display info, LED lights status, etc.

Read the user manual carefully, it can help a lot for using this UPS in the right way. Some FAQ (frequently asked questions) may help you to troubleshoot your problem easily.

| No. | Problem | Possible reason | Solution |
|-----|--|---|---|
| 1 | Utility is connected but the UPS cannot be powered ON. | Input power supply is not connected; Input voltage low; The input switch of the UPS is not switched on. | Measure if the UPS input voltage/frequency is within the window. Check if UPS input is switched on |
| 2 | Utility normal but Utility LED does not light on, and the UPS operates at battery mode | The input breakers of the UPS are not switched on; input cable is not well connected | Switch on the input breaker; Make sure the input cable is well connected. |
| 3 | The UPS does not indicate any failure, but output do not have voltage | Output cable does not well connected; Output breaker do not switch on | Make sure the output cable is well connected; Switch on the output breaker. |
| 4 | Utility LED is flashing | Utility voltage exceeds UPS input range. | If the UPS operates at battery mode, please pay attention to the remaining backup time needed for your system. |
| 5 | Battery LED is flashing but no charge voltage and current | Battery breaker does not switch on, or batteries are damaged, or battery is reversely connected. Battery number and capacity are not set correctly. | Switch on the battery breaker. If batteries are damaged, need to replace whole group batteries, Connect the battery cables correctly; Go to LCD setting of the battery number and capacity, set the correct data. |
| 6 | Buzzer beeps every 0.5 seconds and LCD display "output overload" | Overload | Remove some load |
| 7 | The UPS only works on bypass mode | The UPS is set to ECO mode, or the transfer times to bypass mode are limited. | Set the UPS working mode to UPS type(non-parallel) or to reset the times of transferring to bypass or re-start the UPS |
| 8 | Cannot Black start | Battery switch is not properly closed: Battery fuse is not open: Or Battery low: Battery quantity set wrong; Power breaker in the rear panel not switch ON. | Close the battery switch: Change the fuse: Recharge the battery: Power ON the UPS with AC to set the battery quantity & quantity; Switch on the power breaker. |

Appendix 3 USB communication port definition

Definition of port:

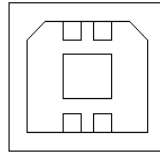

Connection between PC USB port and UPS USB port.

| PC USB port | UPS USB port | Description |
|-------------|--------------|--------------------|
| Pin 1 | Pin 1 | PC : +5V |
| Pin 2 | Pin 2 | PC : DPLUS signal |
| Pin 3 | Pin 3 | PC : DMINUS signal |
| Pin 4 | Pin 4 | Signal ground |

Available function of USB

- ◆ Monitor UPS power status.
- ◆ Monitor UPS alarm info.
- ◆ Monitor UPS running parameters.
- ◆ Timing off/on setting.

Communication data format

Baud rate ----- 9600bps

Byte length ----- 8bit

End bit ----- 1bit

Parity check -----none



CAUTION!

USB and RS232 interface cannot be used at the same time, you can only use one of them at one time.

Appendix 4 RS232 communication port definition

Definition of Male port:

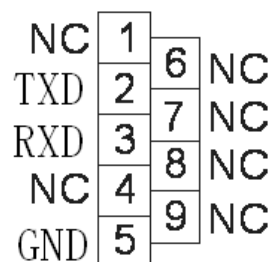

Connection between PC RS232 port and UPS RS232 port

| PC RS232 port | UPS RS232 port | |
|---------------|----------------|---------------------|
| Pin 2 | Pin 2 | UPS send,PC receive |
| Pin 3 | Pin 3 | PC send,UPS receive |
| Pin 5 | Pin 5 | ground |

Available function of RS232

- ◆ Monitor UPS power status.
- ◆ Monitor UPS alarm info.
- ◆ Monitor UPS running parameters.
- ◆ Timing off/on setting.

RS-232 communication data format

Baud rate ----- 9600bps

Byte length ----- 8bit

End bit ----- 1bit

Parity check -----none



CAUTION!

USB and RS232 interface cannot be used at the same time, you can only use one of them at one time.

Appendix 5 RS485 communication port definition

Definition of port:

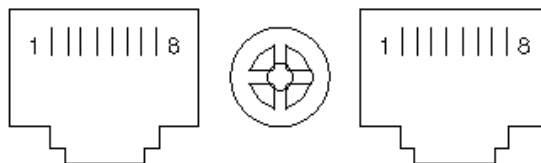

Connection between the Device's RS485 port and UPS RS485 port.

| device(RJ45) | UPS(RJ45) | Description |
|--------------|-----------|-------------|
| Pin 1/5 | Pin 1/5 | 485+ "A" |
| Pin 2/4 | Pin 2/4 | 485 - "B" |
| Pin7 | Pin7 | +12Vdc |
| Pin8 | Pin8 | GND |

Available function of RS485

- ◆ Monitor UPS power status.
- ◆ Monitor UPS alarm info.
- ◆ Monitor UPS running parameters.
- ◆ Timing off/on setting.
- ◆ Battery environment temperature monitoring.
- ◆ Charging voltage modulation depending on batteries temperature

Communication data format

Baud rate ----- 9600bps

Byte length ----- 8bit

End bit ----- 1bit

Parity check -----none



CAUTION!

RS485 port pin7 is 12Vdc!

Appendix 6 Optional port definition

Definition of Male port:

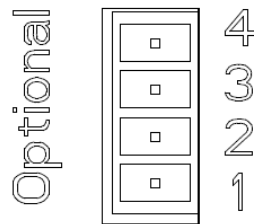

Instruction:

| UPS | Instruction |
|------|-------------|
| Pin1 | Normally NC |
| Pin2 | Normally NO |
| Pin3 | / |
| Pin4 | Common |

Function 1 description (Optional):

- ◆ Drive the bypass breaker when feedback alarm.

Function 2 description (Optional):

- ◆ Drive the battery breaker when battery voltage low.

Appendix 7 REPO instruction

Definition of port:

Connection diagram:

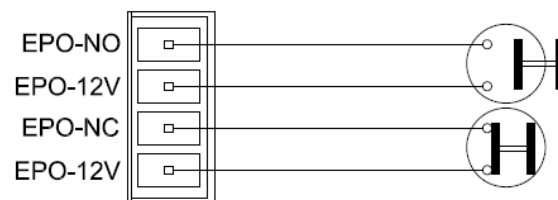

Connection between the button and UPS REPO port.

| Button | UPS REPO | Description |
|--------|----------|-------------|
| Pin 1 | Pin 1 | EPO-NO |
| Pin 2 | Pin 2 | EPO-12V |
| Pin 1 | Pin 3 | EPO-NC |
| Pin 2 | Pin 4 | EPO-12V |

- ◆ A remote emergency stop switch can be installed in a remote location and connection through simple wires to the REPO connector.

